



Product Range Technical Information

Steam Traps and Valves · Electronic Controls · Automation
Special Equipment and Vessels for Heat Recovery

2020



Engineering steam performance

Steam Traps and Valves

Steam Traps and Trap Testing Equipment
Drain Modules

Gravity Circulation Checks
Screwed Non-Return Valves
DISCO Non-Return Valves

DISCOCHECK Dual-Plate Check Valves
DISCO Swing Check Valves

Return Temperature Control Valves
Self-Acting Pressure and Temperature Controllers
Control Valves

Safety Valves
Strainers
Stop Valves

**Industrial Electronics
– System solutions –**

General

Basics, type code
Schematic layout of steam boiler
Old/new equipment at a glance
Type approvals at a glance

Level

The SPECTOR family
SPECTORcompact, *SPECTORmodule*,
SPECTORconnect

Conductivity, continuous boiler blowdown
Intermittent boiler blowdown, temperature
Oil and turbidity detection
Long-distance transmission and parameterization
of operating data
Open and closed loop control

SPECTORcompact, *SPECTORmodule*
SPECTORconnect
Conventional
SPECTORconnect, *SPECTORcom*,
SPECTORcontrol

Special Equipment and Vessels for Heat Recovery

Condensate Recovery and Vessels for Heat Recovery
Desuperheating Plants
Steam Regenerators
Heat-Transfer Installations

Feedwater Deaerating Plants
Mixing Cooler (Blowdown Receiver)
Condensate Dampening Pots
Steam Driers and Purifiers
Vessels

**GESTRA Academy
Tools for Design Engineers
Users & Operators
General Information**

Training Seminars
Programs & sizing software, 2D and 3D CAD drawings
Information on ATEX Directive
Information on Pressure Equipment Directive (PED)

Technical Literature
Technical Documentation
Material Reference Chart, Steam Tables
Design of GESTRA Valves

GESTRA Steam Traps and Steam Trap Monitoring Equipment

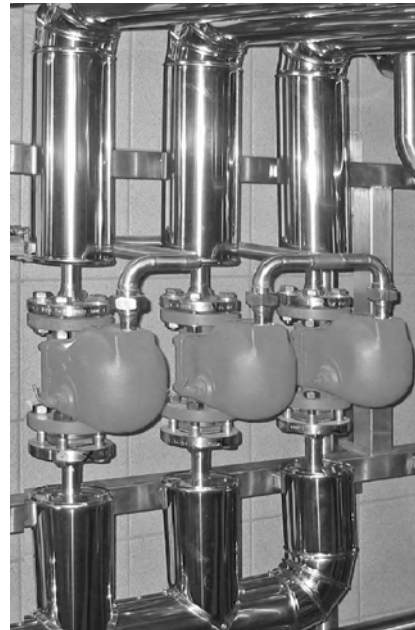

	Page
Steam Trap Selection.....	5
Thermostatic Steam Trap BK with Duo S.S. (Bimetallic) Regulator	6 – 7
Thermostatic Steam Trap MK with Membrane Regulator	8 – 9
Ball Float Trap UNA, UNA Special	10 – 15
Stainless Steel Traps MK, UNA	see MK, UNA
Thermodynamic Steam Trap DK	16 – 17
Steam Traps for Sterile and Aseptic (SIP) Applications SMK	18 – 19
Steam Traps for Special Applications	
Condensate Drain Valves AK	20 – 21
Steam Trap with Adjustable Discharge Temperature UBK	20 – 21
Steam Trap for Low-Pressure Steam Heating Plants MK	20 – 21
Steam Traps for Large Condensate Flowrates TK, GK	20 – 21
Steam Traps for Air-Venting BK, MK	see BK, MK
Steam Trap Units for UNIVERSAL (Swivel) Connectors BK, MK, DK	22
UNIVERSAL (Swivel) Connector Units TS, UC, UCY	23 – 24
Compressed-Air Draining Condensate	
Ball-Float Traps for Draining Condensate from Compressed-Air	
and Other Gas Lines UNA	25
Pump Steam Trap, Compact Condensate Lifter UNA	26
Why Testing Steam Traps.....	27
Steam Trap Monitoring Equipment VK, VKE, VKP	28 – 29
Drain Module QuickEM, QuickEM Control.....	30 – 32
Connecting kit	33
Questionnaire for preparing offers for GESTRA Steam Traps	34

Newcomer to the UNA 4 family: UNA 43, 46 – DN 80 to 150

Proven flexibility now also for large nominal sizes

The new UNA 4 ball-float steam traps in nominal sizes DN 80, DN 100 and DN 150 are now bringing the flexibility of the smaller nominal sizes to applications with large connections. The straight through design, which is slim and compact for this nominal size range, facilitates use in the field. As weight has been reduced by up to 50%, floor-standing installation is no longer essential. The direction of flow can be subsequently adapted to the installation conditions, in the customary manner for the UNA 4. And these steam traps also make use of the tried and tested rolling ball regulator, offering the user reliability based on several decades of practice experience. The cover is designed in such a way that electrodes for monitoring banking-up of condensate and/or loss of steam can be directly fitted. The new UNA 4 is the only ball-float steam trap that can be equipped as standard with a conductive measuring electrode for the real-time monitoring of banking-up of condensate.

A special anti-wear deflector further lengthens the service life of the new UNA 4.

Versions:

- ▶ Body/cover material: 5.1301/5.1301; 1.0619/1.0619
- ▶ Nominal sizes: DN 80, DN 100, DN 150
- ▶ Types of connection: Flange EN1092-1 PN 16, PN 40; flange ASME B 16.5 Class 125RF, 150 RF, 300 RF; flange JIS/KS 10K, 20K
- ▶ Differential pressures: 2 to 40 bar

Special features:

- ▶ Control unit version: with or without thermal venting via thermostatic capsule 5N2 (Duplex/Simplex)
- ▶ Directions of flow: Horizontal L-R, Horizontal R-L, Vertical (can be subsequently adapted)
- ▶ Options:
 - ▶ Manual lifting device
 - ▶ Manual vent valve for Duplex
- ▶ Accessories:
 - ▶ Insulating jacket
 - ▶ Magnetic level gauge for fill level indication

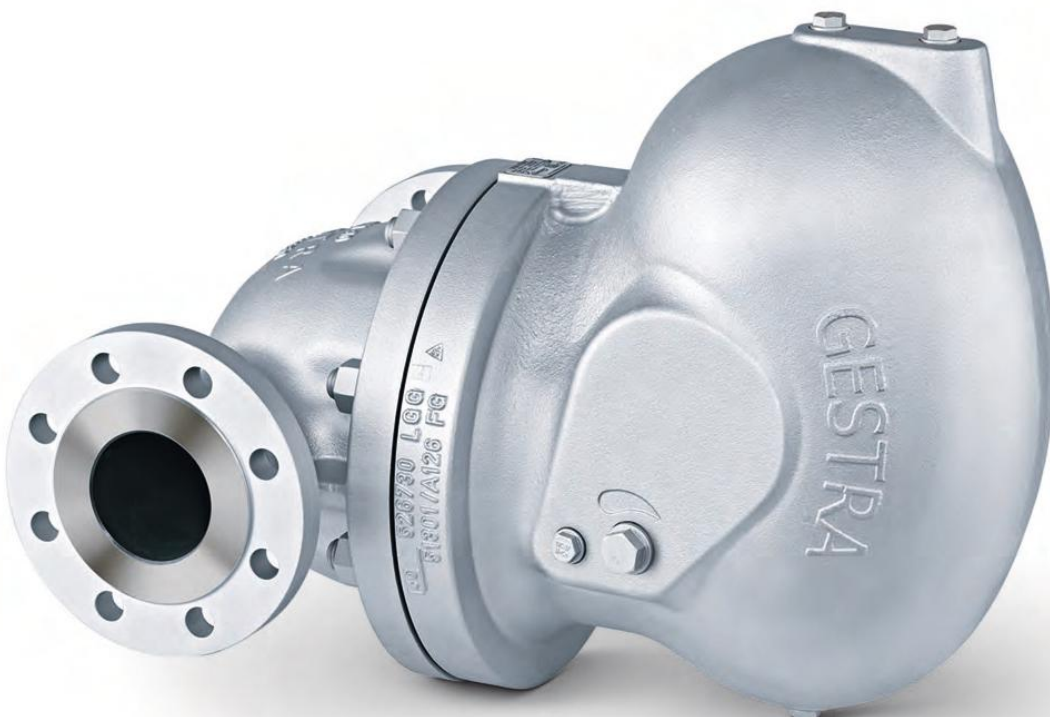

Steam Trap Selection

Not all steam trap types are equally suitable for a given application. Depending on the operating conditions and service in question, one or more systems will be particularly well suited.

The following table contains 15 criteria for steam trap selection based on the operation of the plant and the specific requirements on the part of the plant owner.

Criteria		Steam trap types							Please note:
		Trap type BK with bimetallic regulator	Trap type MK with membrane regulator	Thermodynamic type DK	Ball float trap type UNA with Duplex control	Ball float trap type UNA with Simplex control	Pump steam trap type UNA 2S-PK		
1. Operation with different condensates	Condensate from steam	1	1	1	1	1	1	For "cold" condensates or condensates with a saturation curve deviating from that of water only float traps featuring Simplex control (without thermal venting) can be used.	
	Condensate from compressed air	–	–	–	–	1	1		
	Condensate, distillate from chemical products	–	–	–	–	1	3*)		
2. Different modes of operation	Continuous operation: Constant formation of condensate; flowrate and pressure vary	2	1	1	1	1	1		
	Discontinuous operation: Intermittent formation of condensate; flowrate and pressure vary strongly	2	1	2	1	3*)	1	*) e. g. air venting difficulties	
	Any operation: Heat exchanger may be controlled on the steam side	3**)	2	2*)	1	3*)	1	*) Air venting difficulties, **) With partial load (reduced differential pressure) flowrate possibly not sufficient	
3. Operation with back pressure	Up to approx. 30 % of upstream pressure	1	1	1	1	1	1		
	From 30 % to 60 % of upstream pressure	3*)	1	1	1	1	1	*) Possibly readjustment required	
	> 60 % of upstream pressure	3*)	1	3	1	1	1	*) Possibly readjustment required	
	> 100 % of upstream pressure	–	–	–	–	–	1		
4. Sensitivity to dirt	Very dirty condensate	1	1	1	1	1	1		
5. Air-venting	Automatic	1	1	2	1	3*)	3	*) Manual air-venting	
6. Condensate discharge at definite temperatures	Condensate temperature nearly boiling temperature	2*)	2**)	1	1	1	1	This may apply to small heat exchangers (e. g. laboratory equipment) *) Possibly readjustment required **) Might require special membrane regulator	
	Condensate undercooling approx. 30 K (required)	1*)	1**)	–	–	–	–	*) with U-type regulator or by readjustment **) with U-type capsule	
	Condensate undercooling adjustable	2*)	–	–	–	–	–	*) By a corresponding readjustment reduction in flowrate; if possible use steam trap with adjustable discharge temperature UBK	
7. Frost resistance		1	1	1	1*)	3*)	3	*) Only ensured with V-type design	
8. Condensate discharge without loss of live steam	Intermittent condensate formation	1	1	2	1	1	1		
	Reduced condensate formation (< 10 kg/h)	1	1	2	1	1	1		
	Continuous condensate formation (> 10 kg/h)	1	1	1	1	1	1		
9. Resistance to waterhammer		1	1*)	1	3*)	3*)	1	*) Built-in non-return valve = 1	
10. Non-return valve action		1	1*)	–	–*)	–*)	1	*) Built-in non-return valve = 1	
11. Application in vacuum		3	–	2	–	1	1		
12. Installation in any position		1	1	1	–*)	–*)	–	*) UNA 1... can be converted	
13. Ease of maintenance		1	1	1	1	1	1		
14. Service life of control unit		1	2	2	1	1	1		
15. Application with superheated steam		1	3	2	1/3*)	1	1	*) UNA 1x, 2x, 4x	

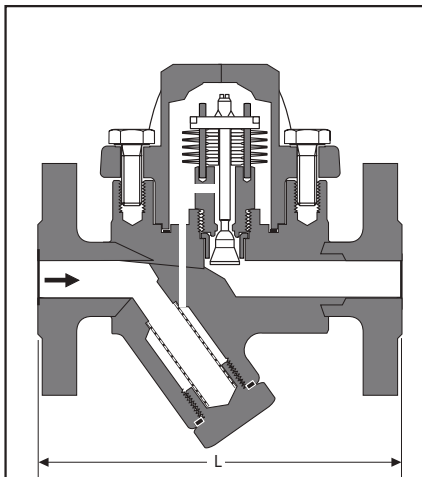

BK 45, BK 46
DN 15, 20, 25



Features of the BK series

- Robust regulator for roughest operating conditions (unaffected by waterhammer and frost)
- Suitable for superheated steam applications
- Automatic air-venting (steam trap can be used for thermal air-venting in steam systems)
- Installation in any position (horizontal and vertical lines)
- Stage nozzle acts as non-return valve
- Stainless steel internals
- Repairable in-line
- Base bushing ensures positive metal-to-metal sealing between body and regulator.
- Up to Δp 275 bar g
- Optional extra: Integrated steam trap monitoring for BK 45 (temperature or steam loss)

Application

For open-loop controlled heating processes.
Draining of

- saturated steam lines
- superheated steam lines
- steam tracers

Can also be used for thermal air-venting

Air-venting

Steam trap for thermostatic air-venting with bimetallic regulator

The thermostatic steam traps with corrosion-resistant Duo S.S. (bimetallic) regulator of the BK series can also be used for air-venting.

Application

Thermostatic steam trap for automatic air-venting and discharge of non-condensable gases and steam/air mixtures from steam lines and heat exchangers.
Special adjustment might be required.

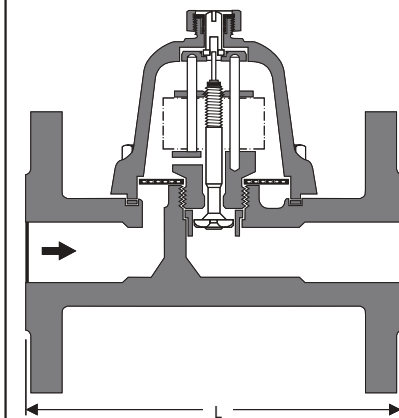

BK 15, DN 40, 50

Pressure/Temperature Ratings

Type	PN / Class	ΔPMX [bar]	Material		Max. Pressure / Temp. Rating ¹⁾		p/T [bar/°C]	
			EN	ASTM	PMA [bar]	TMA [°C]		
BK 45, BK 45U ³⁾	PN 40	22	1.0460	A105	40.0	450	27.6 / 300	13.1 / 450
BK 45, BK 45U ³⁾	Class 300	22	1.0460	A105	51.1	425	39.8 / 300	28.8 / 425
BK 45-LT	Class 300	22	–	SA350 LF2	51.1	425	51.1 / –46 ⁴⁾	28.8 / 425 ⁴⁾
BK 15 DN 40, 50	PN 40	22	1.0460	A105	40.0	450	27.6 / 300	13.1 / 450
BK 15 DN 40, 50	Class 300	22	1.0460	A105	51.1	425	39.8 / 300	28.8 / 425
BK 46	PN 40	32	1.5415	A182-F1 ²⁾	40.0	450	39.0 / 250	27.6 / 450
BK 46	Class 300	32	1.5415	A182-F1 ²⁾	51.7	450	41.1 / 250	29.8 / 450
BK 37	PN 63/100	45	1.5415	A182-F1 ²⁾	100.0	530 ⁴⁾	100.0 / 450 ⁴⁾	30.9 / 530 ⁴⁾
BK 27N DN 40, 50	PN 63	45	1.5415	A182-F1 ²⁾	63.0	530	54.0 / 300	13.0 / 530
BK 28	PN 100	85	1.5415	A182-F1 ²⁾	100.0	530 ⁴⁾	100.0 / 450 ⁴⁾	30.9 / 530 ⁴⁾
BK 29	PN 160	110	1.7335	A182-F12	160.0	540 ⁴⁾	131.5 / 450 ⁴⁾	44.5 / 540 ⁴⁾
BK 212	PN 630	275	1.7383	A182-F22	630.0 ⁴⁾	540 ⁴⁾	447.0 / 500 ⁴⁾	261.0 / 540 ⁴⁾
BK 212-F91	–	275	1.4903	A182-F91	775.0 ⁴⁾	580 ⁴⁾	607.0 / 500 ⁴⁾	205.0 / 580 ⁴⁾
BK 212-S	PN 630	275	1.7383	A182-F22	630	580	289.0 / 540 ⁴⁾	163.0 / 580 ⁴⁾
BK 212-F91-S	–	275	1.4903	A182-F91	775	625	473.0 / 575 ⁴⁾	255.0 / 625 ⁴⁾
BK 212-1.4901	–	275	1.4901	A182-F92 ²⁾	800	650	418.0 / 600 ⁴⁾	207.0 / 650 ⁴⁾
BK 37-ASME	Class 400/600	45	–	A182-F12	103.4 ⁴⁾	500 ⁴⁾	85.7 / 300 ⁴⁾	42.8 / 500 ⁴⁾
BK 28-ASME	Class 600	85	–	A182-F12	103.4 ⁴⁾	500 ⁴⁾	85.7 / 300 ⁴⁾	42.8 / 500 ⁴⁾
BK 29-ASME	Class 900	110	–	A182-F12	155.1	540 ⁴⁾	101.4 / 450 ⁴⁾	40.2 / 540 ⁴⁾
BK 212-ASME	Class 2500	275	–	A182-F22	430.9 ⁴⁾	593 ⁴⁾	235.0 / 500 ⁴⁾	63.0 / 593 ⁴⁾

¹⁾ Limits for body/cover. Functional requirements may restrict the use to below the limits quoted.

For full details on limiting conditions depending on end connection and type of regulator see data sheet.

²⁾ Material complies with EN and ASTM requirements.

³⁾ Opening undercooling approx. 30 K.

⁴⁾ Only applicable for traps with butt-weld (BW) or socket-weld (SW) ends DN 25. Note that limits will be lower for traps with other dimensions or flanged end connections.

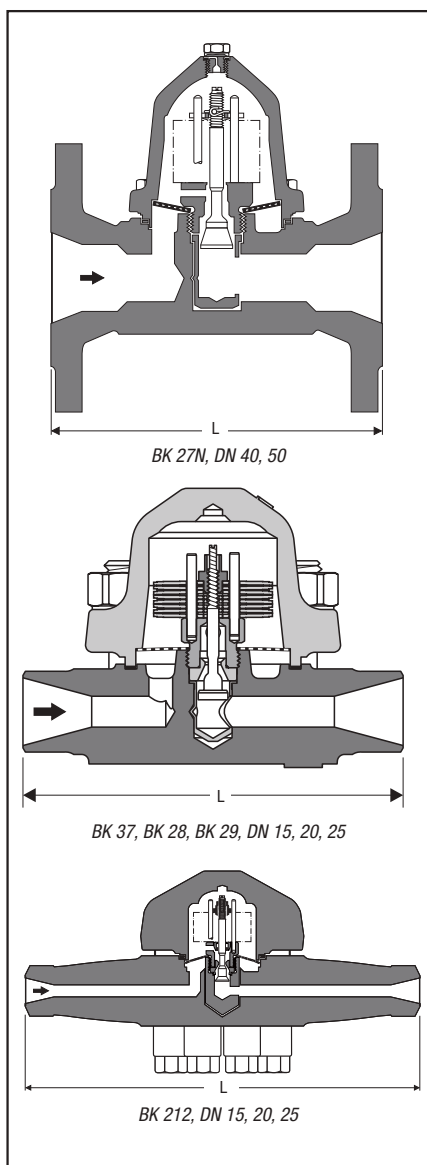

Available End Connections and Overall Lengths in mm

Type	Connection	DN 15 [1/2"]	DN 20 [3/4"]	DN 25 [1"]	DN 40 [1 1/2"]	DN 50 [2"]
BK 45 <small>RHOMBUSline®</small>	Flanged EN PN 40	150	150	160	230	230
	Flanged ASME 150 ¹⁾	150	150	160	230	230
	DN 15 – 25 Flanged ASME 300 ¹⁾	150	150	160	230	230
BK 15 DN 40, 50	Screwed sockets	95	95	95	130	230
	Socket-weld (SW)	95	95	95	130	230
	Butt-weld (BW)	200	200	200	250	250
BK 46 <small>RHOMBUSline®</small>	Flanged EN PN 40	150	150	160	–	–
	Flanged ASME 300	150	150	160	–	–
	Screwed sockets	95	95	95	–	–
	Socket-weld (SW)	95	95	95	–	–
BK 27N DN 40,50	Flanged EN PN 40	–	–	–	230	230
	Flanged EN PN 63	–	–	–	260	300
	Flanged ASME 400/600	–	–	–	241	292
	Socket-weld (SW)	–	–	–	180	180
	Butt-weld (BW)	–	–	–	180	180
BK 37	Flanged EN PN 63/100	210	230	230	–	–
	BK 28	Socket-weld (SW)	160	160	160	–
Butt-weld (BW)		160	160	160	–	–
BK 29	Flanged EN PN 160	210	–	230	–	–
	Socket-weld (SW)	160	160	160	–	–
	Butt-weld (BW)	160	160	160	–	–
BK 212... Series	Butt-weld (BW)	330	330	330	–	–
	Socket-weld (SW)	330	330	330	–	–
BK 37-ASME	Flanged ASME 400/600	230	230	230	–	–
	Socket-weld (SW)	160	160	160	–	–
	Butt-weld (BW)	160	160	160	–	–
BK 28-ASME	Flanged ASME 400/600	230	230	230	–	–
	Socket-weld (SW)	160	160	160	–	–
	Butt-weld (BW)	160	160	160	–	–
BK 29-ASME	Flanged ASME 900/1500	230	230	254	–	–
	Socket-weld (SW)	200	200	200	–	–
	Butt-weld (BW)	200	200	200	–	–

¹⁾ BK 45 with ASME flanges: overall length 172 mm available on request.

Capacity Charts

The charts show the maximum hot condensate capacities.

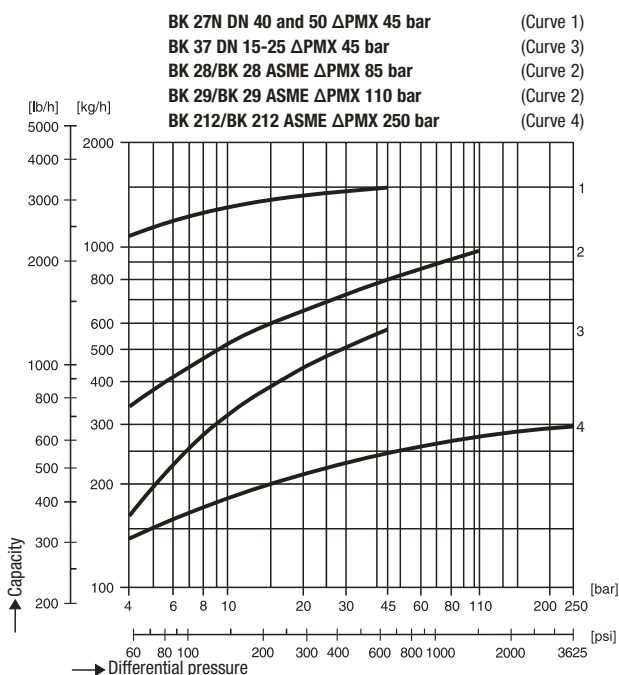
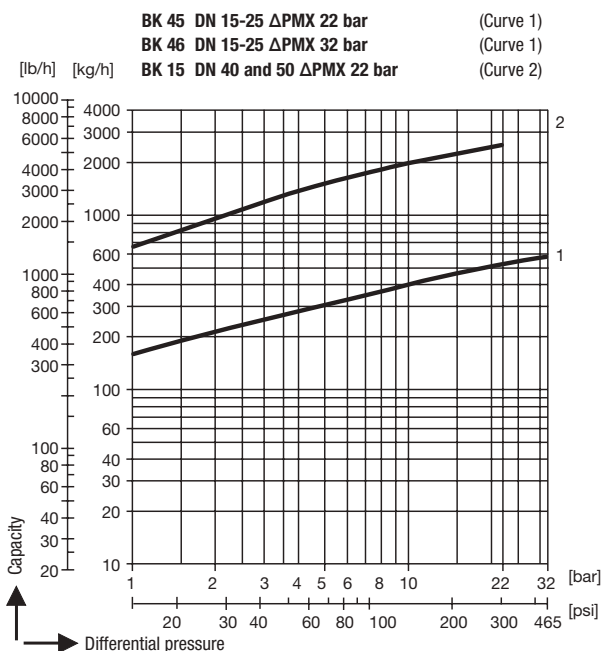

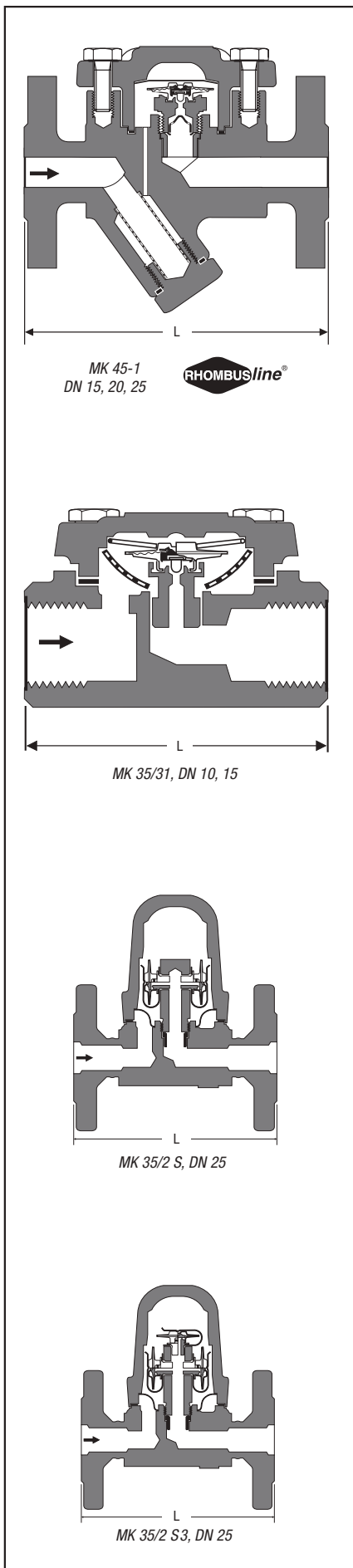

Features of the MK series

- Very sensitive response characteristic
- Function is not impaired by high back pressure
- Automatic air-venting (trap can be used for thermal air-venting in steam systems)
- Installation in any position (horizontal and vertical lines)
- High hot-water capacities even with low differential pressures
- With tandem seat (double sealing) for low condensate flowrates
- Built-in non-return valve (only MK 45)
- Stainless steel internals (corrugated membrane of Hastelloy)
- Design “U” with undercooling capsule: utilization of a certain amount of sensible heat by banking-up of condensate, decreasing the amount of flash steam
- Optional extra: Integrated condensate monitoring for MK 45 (temperature or steam loss)

Application

Type	
MK 45-1 MK 35/31 ¹⁾	With tandem seat (double sealing) For low condensate flowrates, steam-tracing, steam-line drainage, air-venting
MK 45-2 MK 35/32 ¹⁾	With single seat For medium condensate flowrates, steam-tracing, drainage of heat exchangers, air-venting
MK 25/2 ¹⁾ MK 25/2 S ¹⁾ MK 35/2 S ¹⁾ MK 35/2 S3 ¹⁾	With single seat For large condensate flowrates, drainage of heat exchangers
MK 36/51 ¹⁾ MK 36/52 ¹⁾	With tandem seat (double sealing) – with flat gasket For small/large condensate flowrates, steam tracing, steam-line drainage, venting and vacuum-breaking. Also suitable for food, biological and pharmaceutical applications.
MK 45 A-1 MK 45 A-2	For small and large condensate flowrates; steam-tracing, steam-line drainage, air-venting

¹⁾ Can also be used for vacuum breaking (aerating).

Air Venting

Steam Trap for Thermostatic Air-Venting with Membrane Regulator

The thermostatic steam traps with membrane regulators of the MK series can also be used for air-venting.

Application

Thermostatic steam trap for automatic air-venting and discharge of non-condensable gases and steam/air mixtures from steam lines and heat exchangers.

A special type of membrane regulator capsule might be required.

Pressure/Temperature Ratings

Type	PN / Class	Δ PMX [bar]	Material		Max. Pressure/Temp. Rating ¹⁾			p/T [bar/°C]
			EN	ASTM	PMA [bar]	TMA [°C]		
MK 35/31, MK 35/32	PN 25	21	1.0460	A105	25.0	400	18.6 / 225	14.4 / 400
MK 45-1, MK 45-2	PN 40	32	1.0460	A105	40.0	450	27.6 / 300	13.1 / 450
MK 45-1, MK 45-2	Class 300	32	1.0460	A105	51.1	425	39.8 / 300	28.8 / 425
MK 35/2 S, DN 25 MK 35/2 S3, DN 25	PN 40	32	1.0460	A105	40.0	450	27.6 / 300	13.1 / 450
MK 25/2, MK 25/2 S, DN 40, 50	PN 40	32	1.0460/ 1.0619	A105/ A216-WCB	40.0	450	27.6 / 300	13.1 / 450
MK 36/51, MK 36/52	–	32	1.4301 ²⁾	A479-F304	49.0	400	32.0 / 250	28.0 / 400
MK 45 A-1, MK 45 A-2	PN 40	32	1.4404	A182-F316L	40.0	400	27.6 / 300	25.7 / 400 ³⁾
MK 45 A-1, MK 45 A-2	Class 300	32	1.4404	A182-F316L	41.4	400	26.1 / 300	24.3 / 400 ³⁾

¹⁾ Limits for body/cover. Functional requirements may restrict the use to below the limits quoted.
For full details on limiting conditions depending on end connection and type of regulator see data sheet.

²⁾ EN material comparable to ASTM material.

³⁾ If the operating temperatures exceed 300 °C intercrystalline corrosion may occur. Do not subject the equipment to operating temperatures higher than 300 °C unless intercrystalline corrosion can be ruled out.

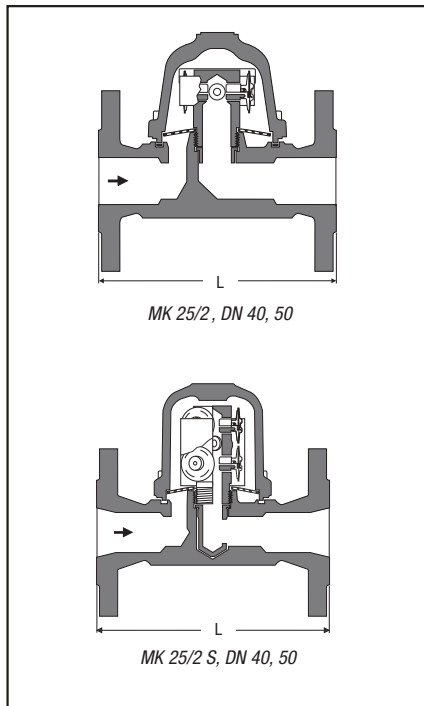

Available End Connections and Overall Length

Type	Connection	Overall length (L) in mm						
		DN 8 1/4"	DN 10 3/8"	DN 15 1/2"	DN 20 3/4"	DN 25 1"	DN 40 1 1/2"	DN 50 2"
MK 45-1	Flanged EN PN 40	–	–	150	150	160	–	–
MK 45-2	Flanged ASME 150 ¹⁾	–	–	150	150	160	–	–
MK 45 A-1	Flanged ASME 300 ¹⁾	–	–	150	150	160	–	–
MK 45 A-2	Screwed sockets	–	–	95	95	95	–	–
MK 35/2 S3 only DN 25	Socket-weld (SW)	–	–	95	95	95	–	–
MK 35/2 S only DN 25	Butt-weld (BW) ²⁾	–	–	200	200	200	–	–
MK 35/31	Screwed sockets	–	70	70	–	–	–	–
MK 35/32	Socket-weld (SW)	–	–	95	–	–	–	–
MK 25/2 DN 40 – 50	Flanged EN PN 40	–	–	–	–	–	230	230
MK 25/2 S DN 40 – 50	Flanged ASME 150	–	–	–	–	–	230	230
	Flanged ASME 300	–	–	–	–	–	230	230
	Screwed sockets	–	–	–	–	–	130	230
	Socket-weld (SW)	–	–	–	–	–	130	230
MK 36/51	Screwed sockets	65	65	65	65	–	–	–
MK 36/52	Union butt-weld nipples ³⁾	–	–	150	–	–	–	–
	Hinged clamp	–	65	65	65	65	–	–

STAINLESS STEEL

STAINLESS STEEL

- 1) MK 45 with ASME flanges: overall length 172 mm available on request.
- 2) Only MK 45
- 3) Made of carbon steel or stainless steel

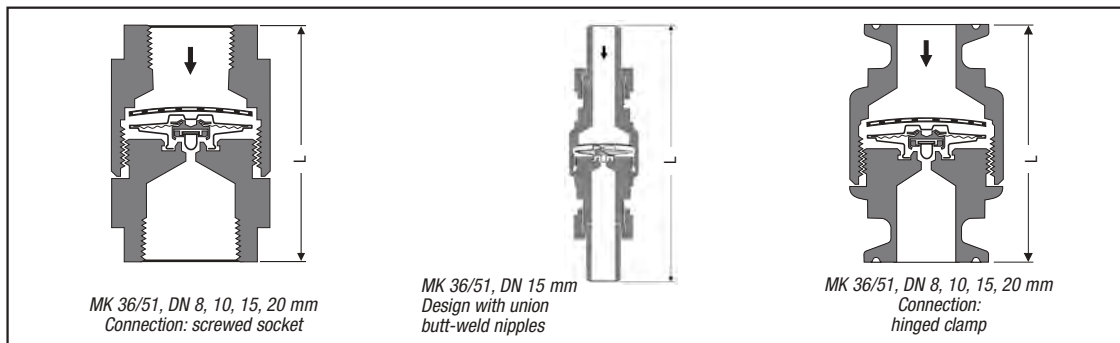

MK 36/51, DN 8, 10, 15, 20 mm
Connection: screwed socket

MK 36/51, DN 15 mm
Design with union
butt-weld nipples

MK 36/51, DN 8, 10, 15, 20 mm
Connection:
hinged clamp

Capacity Charts

The charts show the maximum hot condensate capacities.

- MK 45-1/MK 45A-1** (Curve 4) **MK 35/31** (Curve 1)
- MK 45-2/MK 45A-2** (Curve 5) **MK 35/32** (Curve 2)
- MK 36/51** (Curve 3) **MK 36/52** (Curve 2)
- MK 25/2 S, DN 40, 50** (Curve 1) **MK 35/2 S3, DN 25** (Curve 3)
- MK 25/2, DN 40, 50** (Curve 2) **MK 35/2S, DN 25** (Curve 4)

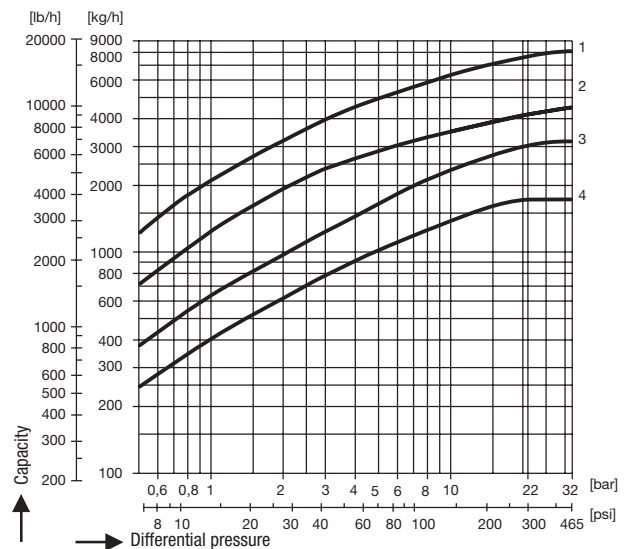
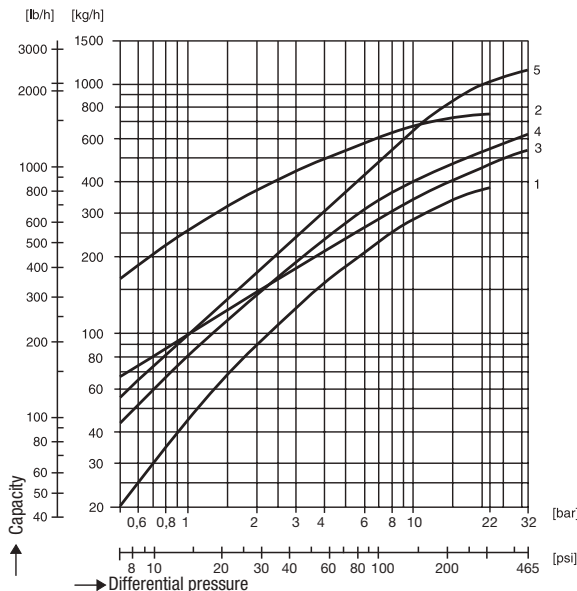

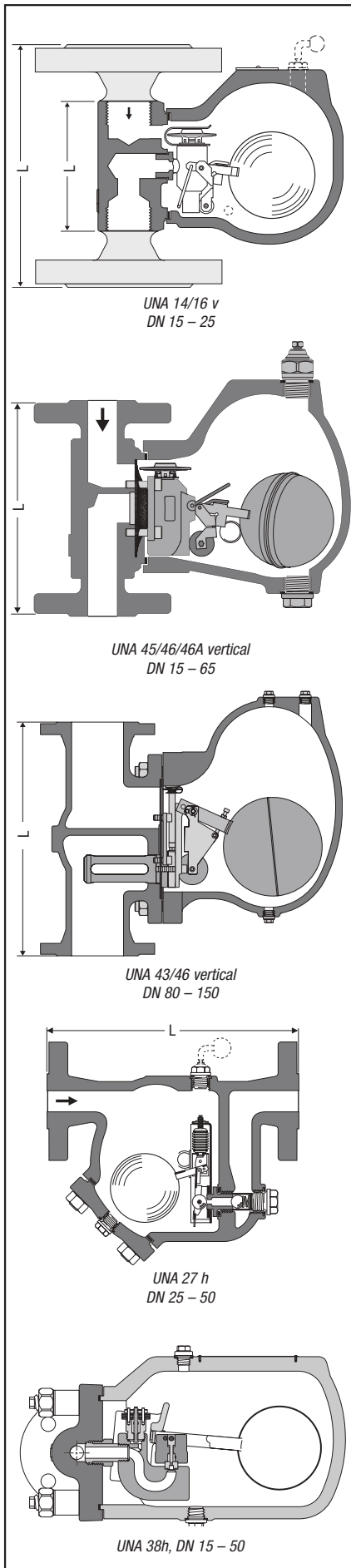

Features of the UNA series

- Unaffected by back pressure and condensate temperature
- No loss of live steam due to continuous water seal at the seat
- No banking-up of condensate even with extreme load and pressure fluctuations
- Particularly well suited for heat exchangers controlled from the steam side
- Unaffected by dirt
- Automatic thermostatic air-venting (Duplex design)
- Ideal for discharging cold condensates, distillates and condensates derived from chemical products (Simplex design)
- Repairable in-line
- Thanks to the rolling ball valve only reduced operating forces and small control units are required (compact, lightweight design for large flowrates)
- Internals made from corrosion-resistant stainless steels
- UNA 14, 16, 45, 46, 38: Body can be easily repositioned to convert the flow direction from left to right or vice versa or to change to vertical flow.
- UNA 45, 46 DN 40-65 optionally available with MAX controller for very large flowrates (conversion standard -> MAX controller not possible).

Application

Condensate discharge without banking-up, even at varying operating conditions and back pressure. Automatic air-venting (Duplex design). Also for the discharge of cold condensates and distillates, and for draining gas and compressed air systems (Simplex design).

Pressure/Temperature Ratings and Designs

Type	PN / Class	Δ PMX [bar]	Material		Max. Pressure / Temp. Rating ¹⁾			
			EN	ASTM	PMA [bar]	TMA [°C]	p / T [bar/°C]	
UNA 14	PN 25	13	5.3103	–	25.0	350	19.4 / 200	15.0 / 350
UNA 16	PN 40	22	1.0460 / 1.0619	A105 / A216-WCB	40.0	400	25.8 / 300	23.1 / 400
UNA 43	PN 16 / CL125	13	5.1301 / 5.1301	(A126-B) / (A126-B)	16.0 / 13.8	300 / 232	12.8 / 200 9.6 / 200	9.6 / 300 8.6 / 232
UNA 45	PN 40 / CL300	32	1.0460 / 5.3103	A105 / (A395)	40 / 51.1	350 / 345	33.3 / 200 43.8 / 200	25.7 / 350 37.8 / 345
UNA 46 (DN 15 – 65)	PN 40 / CL300	32	1.0460 / 1.0619	A105 / A216WCB	40 / 51.1	450 / 425	27.6 / 300 39.8 / 300	13.1 / 450 28.8 / 425
UNA 46 (DN 80 – 150)	PN 40 / CL300	40	1.0619 / 1.0619	A216WCB / A216WCB	40 / 51.1	450 / 425	27.6 / 300 39.8 / 300	13.1 / 450 28.8 / 425
UNA 27h ³⁾	PN 63	45	1.5419	A217-WC1 ²⁾	63.0	450	54.0 / 300	43.5 / 450
UNA 38	PN 100	80	1.5415/ 1.7357	A182-F1 / A217-WC6 ²⁾	100.0	530	69.0 / 450	22.3 / 530
UNA 38 High-temperature	PN 100	80	1.7335/ 1.7357	A182-F12 / A217-WC6 ²⁾	100.0	530	83.7 / 450	32.4 / 530
UNA 39	PN 160	140	1.7335	A182-F12	160.0	550	104.3 / 500	37.3 / 550
UNA-Special Type 62B	PN 16	16	1.0425	A516Gr-60 ²⁾	16.0	300	11.3 / 250	10.2 / 300
UNA	PN 25	22	1.0619	A216-WCB	25.0	400	22.0 / 200	14.8 / 400
UNA-Special	PN 63	45	1.5419	A217-WC1 ²⁾	63.0	450	54.0 / 300	43.5 / 450
UNA 16A STAINLESS STEEL	PN 40	22	1.4404 / 1.4408	A182-316L / A351-CF8M	40.0	300	29.3 / 200	25.8 / 300
UNA 46A STAINLESS STEEL	PN 40 / CL300	32	1.4404 / 1.4408	F316L / CF8M	40 / 41.4	450 / 425	27.6 / 300 26.1 / 300	25.0 / 450 ⁴⁾ 23.9 / 425 ⁴⁾

- ¹⁾ Limits for body/cover. Functional requirements may restrict the use to below the limits quoted. For full details on limiting conditions depending on end connection and type of regulator see data sheet.
- ²⁾ ASTM nearest equivalent is stated for guidance. Physical and chemical properties comply with EN.
- ³⁾ These types/materials are only available for design h for installation in horizontal lines.
- ⁴⁾ If the operating temperatures exceed 300 °C intercrystalline corrosion may occur. Do not subject the equipment to operating temperatures higher than 300 °C unless intercrystalline corrosion can be ruled out.

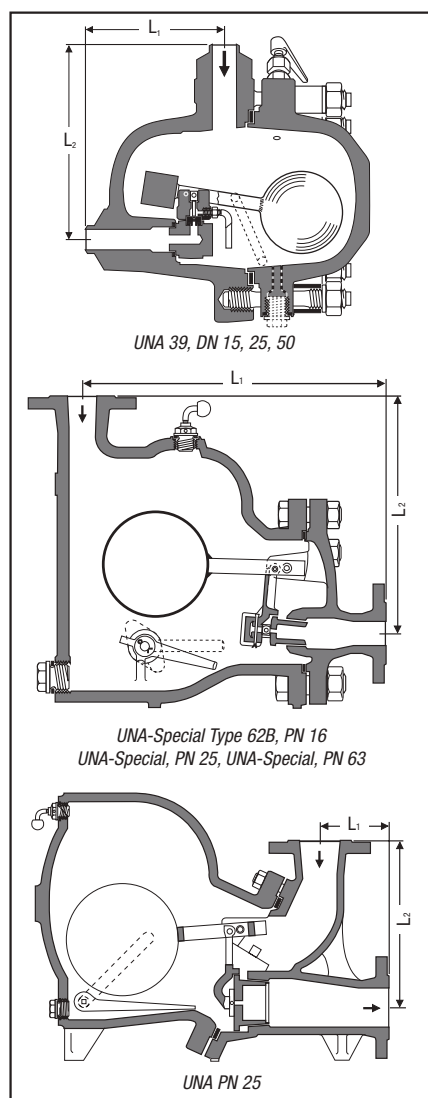

Simplex: Float control (without thermostatic bellows)
 Duplex: Flow control + automatic air-venting
 Simplex-R: Float control + inner vent pipe

Available End Connections and Overall Length

Type	Connection	Overall length (L) in mm					
		DN 15 1/2"	DN 20 3/4"	DN 25 1"	DN 40 1 1/2"	DN 50 2"	DN 65 2 1/2"
UNA 14h, 14v	Flanged EN PN 25	150	150	160	–	–	–
	Screw sockets	95	95	95	–	–	–
UNA 16h, 16v, UNA 16Ah, 16Av	Flanged EN PN 40	150	150	160	–	–	–
	Flanged ASME 150 RF	150	150	160	–	–	–
	Screw sockets	95	95	95	–	–	–
	Socket-weld (SW)	95	95	95	–	–	–
	Butt-weld (BW)	200	200	200	–	–	–
UNA 45 UNA 46 UNA 46A	Flanged EN PN40	150	150	160	230	230	290
	Flanged ASME C1150	150	150	160	241	267	292
	Flanged ASME C1300	150	150	160	241	267	292
	Screw ISO-G	95	95	95	165	165	–
	Screw socket NPT	95	95	95	165	165	–
	Socket-weld end (SW) EN/ASME	95	95	95	165	–	–
	SW via transition piece EN/ASME	–	–	–	–	267	–
	SW via transition piece EN	–	–	–	–	–	292
	SW via transition piece ASME	–	–	–	–	–	292
	Butt-weld end via transition piece EN	200	200	200	241	267	292
	Butt-weld end via transition piece ASME	200	200	200	241	267	292
UNA 27h ¹⁾ and UNA 38	Flanged EN PN 63/PN 100	300	300	300	420	416	–
	Flanged ASME 600 RF	300	300	300	421	427	–
	Socket-weld / SW via transition pieces	300	300	300	420 ²⁾	420 ²⁾	–
	Butt-weld / BW via transition pieces	300	300	300	420 ²⁾	420 ²⁾	–
UNA 39		L ₁ /L ₂		L ₁ /L ₂		L ₁ /L ₂	
	Flanged EN PN 160	215/285	–	230/300	–	245/315	–
	Flanged ASME 900 RF	240/310	–	250/320	–	280/350	–
	Butt-weld (BW)	170/240	–	170/240	–	170/240	–

¹⁾ not available as DN 15 + DN 20 ²⁾ UNA 38 socket-weld (SW) ends and butt-weld (BW) ends DN 40 + DN 50: 300 mm, SW and BW via transition pieces: 420 mm

Type	Connection		Length L ₁ /L ₂ in mm			
			DN 65 2 1/2"	DN 80 3"	DN 100 4"	DN 150 6"
UNA 43	Flanged EN PN 16	L	–	450	450	500
	Flanged ASME CL 125	L	–	457	547	502
	Flanged JIS/KS 10 K	L	–	457	457	502
UNA 46	Flanged EN PN 40	L	–	450	450	500
	Flanged ASME CL 150	L	–	457	457	502
	Flanged ASME CL 300	L	–	457	457	502
	Flanged JIS/KS 10K	L	–	457	457	502
	Flanged JIS/KS 20K	L	–	457	457	502
UNA-Special Type 62B, PN 16	Flanged EN PN 16	L ₁	–	–	700	–
		L ₂	–	–	595	–
UNA PN 25	Flanged EN PN 25	L ₁	–	–	140	–
		L ₂	–	–	400	–
UNA-Special PN 63	Flanged EN PN 63	L ₁	565	690	700	–
		L ₂	400	435	450	–

Available Designs

Type	End connection options			Orifices (AO) for max. differential pressure	Control unit		
	horizontal	vertical	angle pattern		Simplex	Duplex	Simplex-R
UNA 14	x ¹⁾	x ¹⁾		AO 4, 13	x	x	x
UNA 16, 16A	x ¹⁾	x ¹⁾		AO 4, 13, 22	x	x	x
UNA 43, UNA 45, UNA 46, UNA 46A	x ¹⁾	x ¹⁾		AO 2, 4, 8, 13, 22, 32, 40 ³⁾ , 4 MAX ⁴⁾ , 8 MAX ⁴⁾ , 13 MAX ⁴⁾ , 22 MAX ⁴⁾ , 32 MAX ⁴⁾	x	x	
UNA 27h	x			AO 16, 28, 45	x	x	
UNA 38	x ¹⁾	x ¹⁾		AO 50, (64), 80, 80 MAX	x	x	
UNA 39			x	AO 80, 110, 140, 140 MAX	x		
UNA-Special Type 62B, PN 16			x	AO 2, 3.5, 5, 10, 16	x ⁶⁾		
UNA PN 25			x	AO 2, 3.5, 5, 8, 12, 16, 22	x ⁶⁾		
UNA-Special PN 63			x	AO 16, 22, 32, 40, 45	x ⁶⁾		

¹⁾ Connection orientation can be changed on site, trap body for horizontal-right available

²⁾ Simplex: Flow control + hand vent valve + float lifting lever ³⁾ DN 80, 100, 150 ⁴⁾ DN 40, 50, 65

Optional Items for Ball-Float Traps

Item	Type
Sightglass cover	UNA 45
Cover for installing electrodes	UNA 45
Float lifting lever with gasket	UNA 43, 45, 46, 46 A, 27 h, 38
Vent valve with gasket (for Duplex design)	UNA 43, 45, 46, 46 A, 27 h, 38
Inner bypass (adjustable)	UNA 45, 46, 46 A

Capacity Charts

The charts show the maximum hot condensate capacities for the range of float-controlled orifices (AO) and sizes available.

UNA 14, UNA 16, UNA 16A

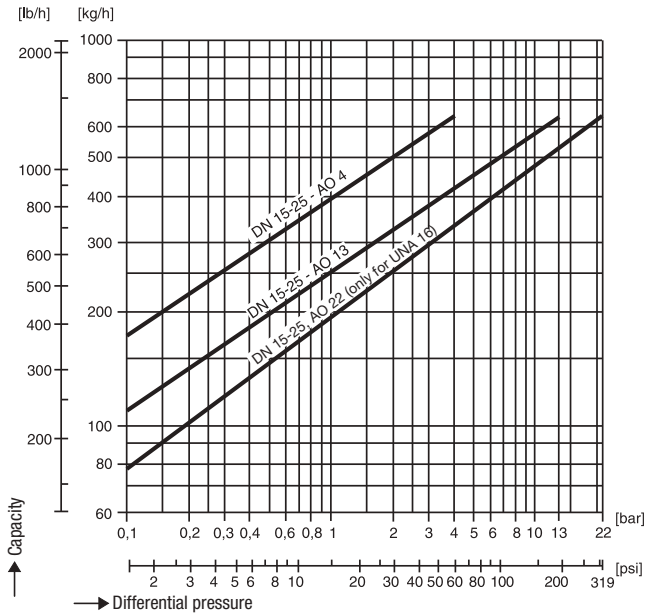

UNA 45, UNA 46, UNA 46A

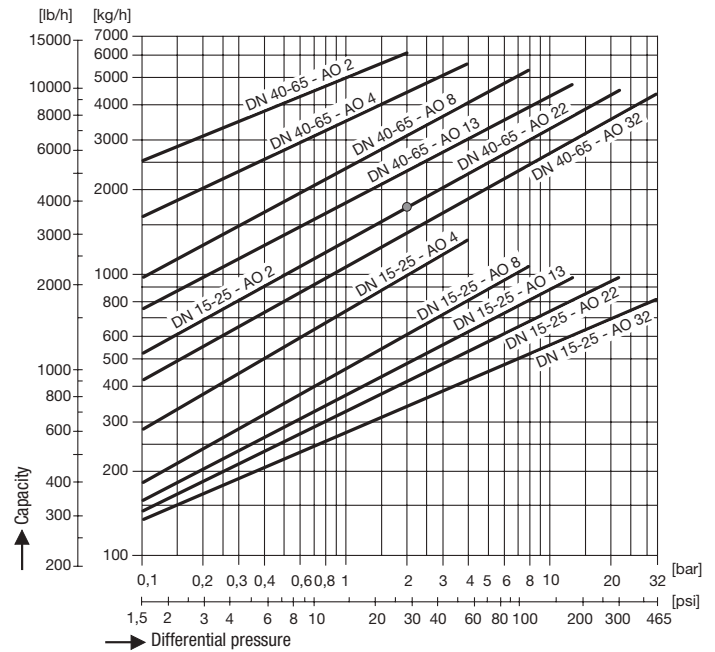

UNA 27 h

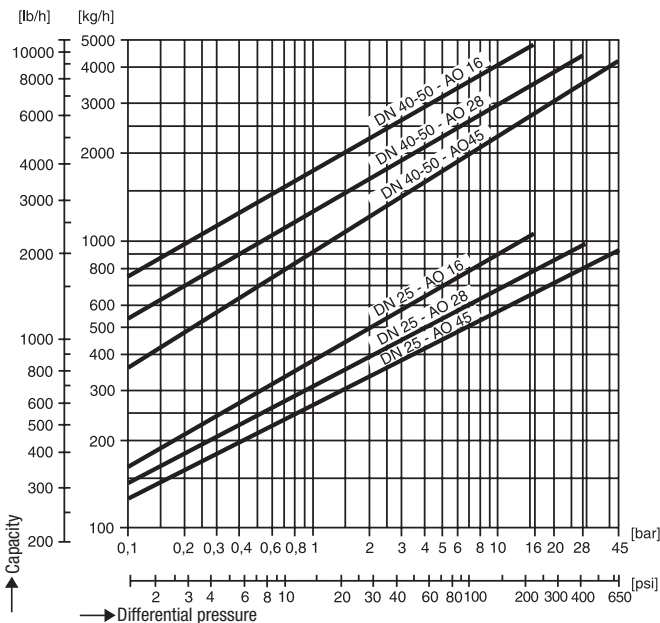

UNA 45 MAX, UNA 46 MAX, UNA 46A MAX

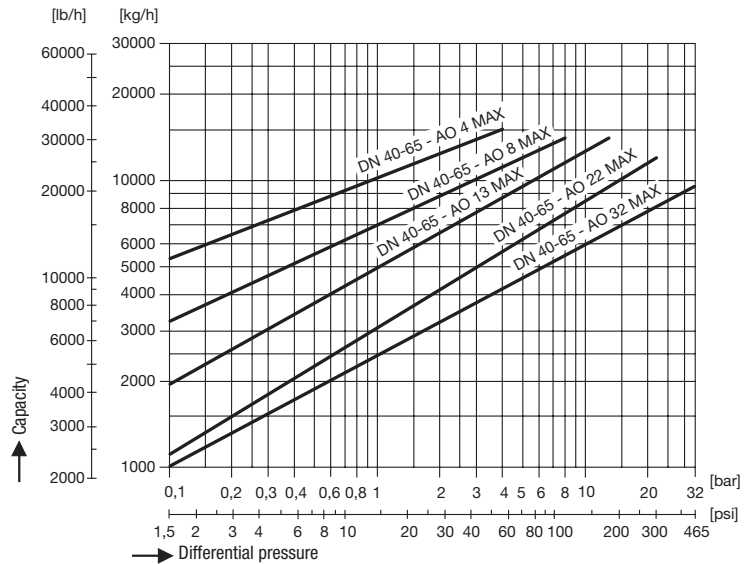

Capacity Charts

The charts show the maximum hot condensate capacities for the range of float-controlled orifices (AO) and sizes available.

UNA 38

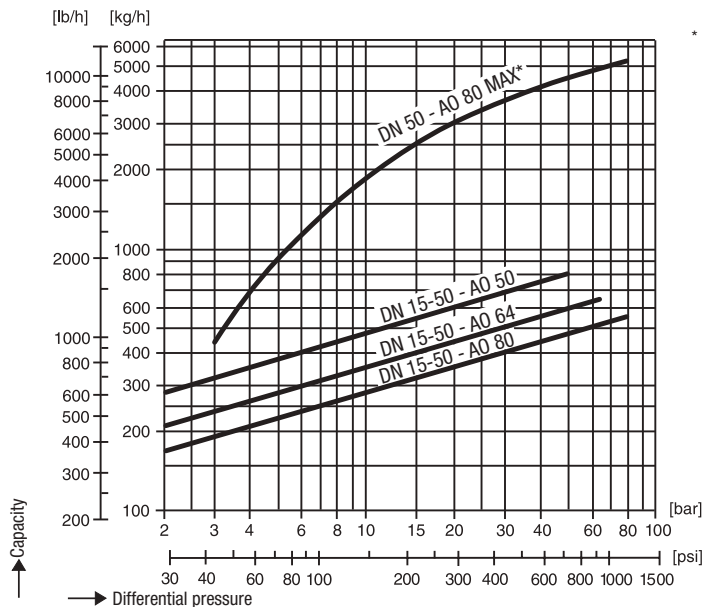

UNA 39

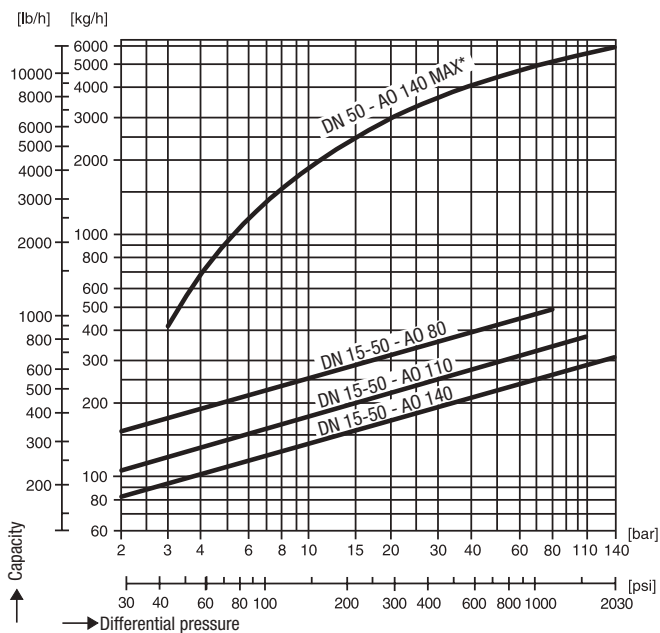

Capacity Charts

The charts show the maximum hot condensate capacities for the range of orifices (AO) and sizes available.

UNA 43, UNA 46

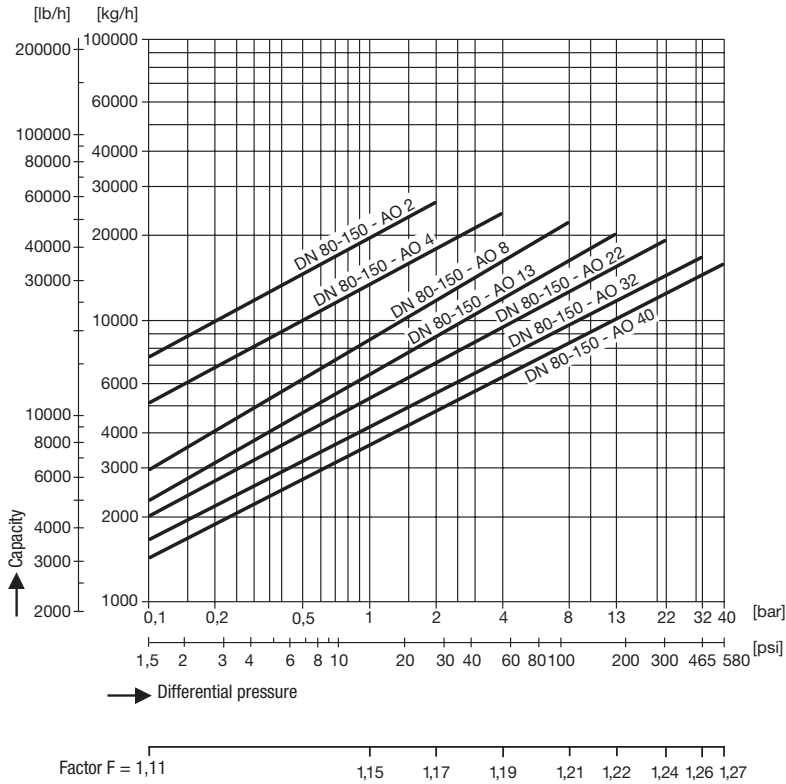

UNA-Special Type 62B, PN 16

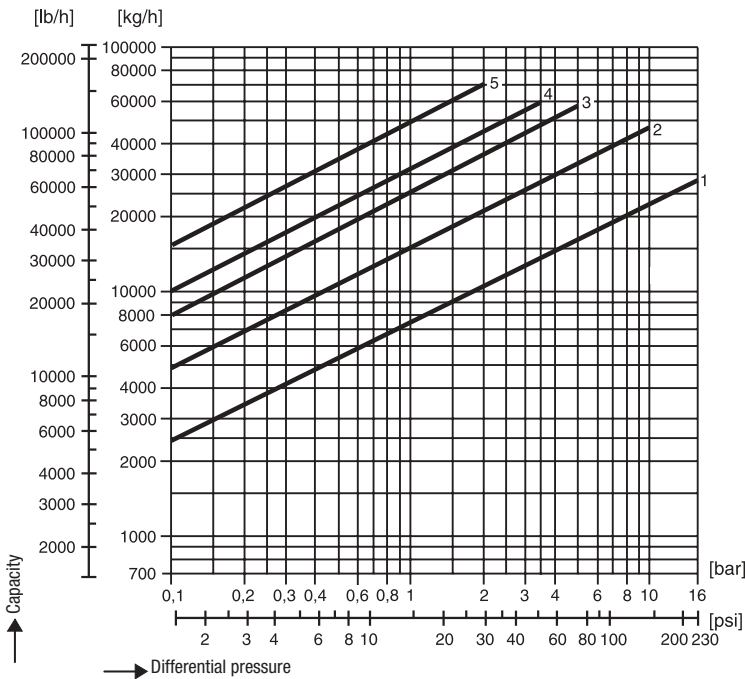

Available orifices (AO)		
1	DN 100	AO 16
2	DN 100	AO 10
3	DN 100	AO 5
4	DN 100	AO 3.5
5	DN 100	AO 2

Capacity Charts

The charts show the maximum hot condensate capacities for the range of orifices (AO) and sizes available.

UNA PN 25, DN 80 and 100

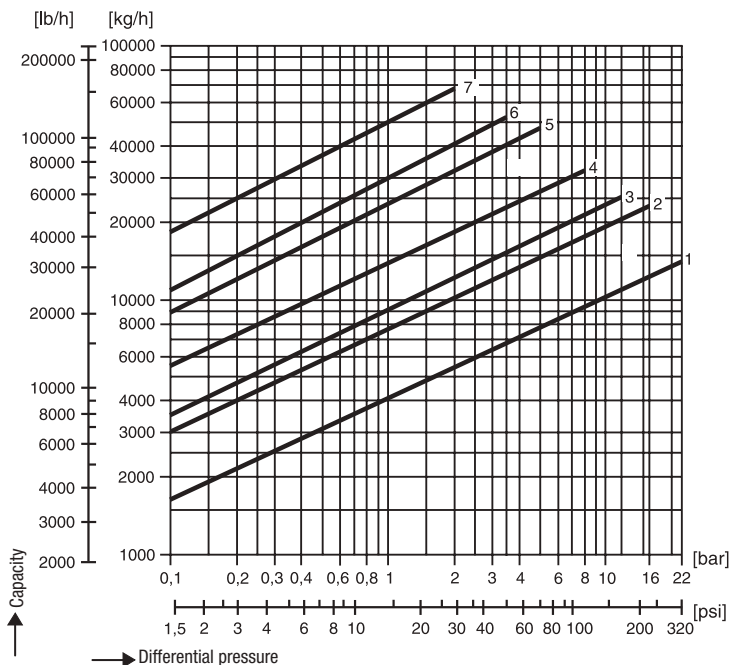

Available orifices (AO)		
1	DN 100	AO 22
2	DN 100	AO 16
3	DN 100	AO 12
4	DN 100	AO 8
5	DN 100	AO 5
6	DN 100	AO 3.5
7	DN 100	AO 2

UNA-Special PN 63 (PN 40)

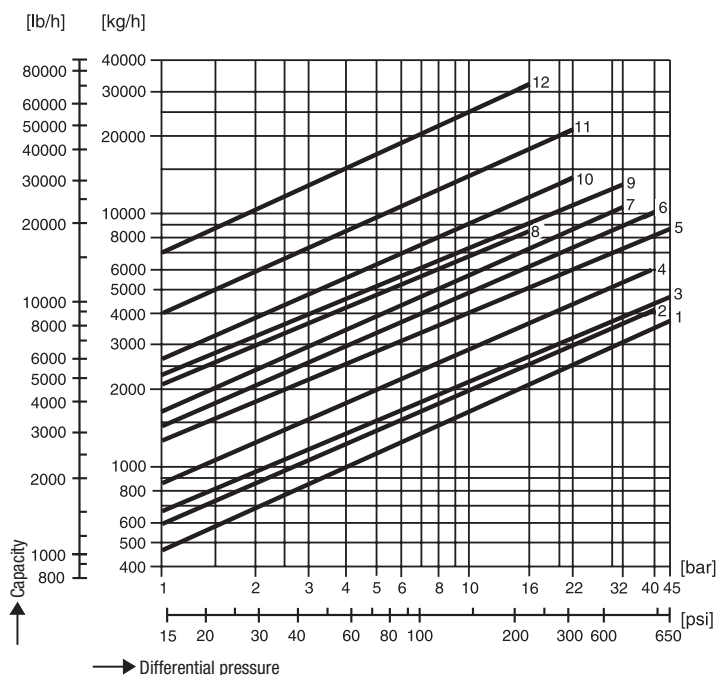

Available orifices (AO)		
1	DN 65	AO 45
2	DN 65	AO 40
3	DN 80	AO 45
4	DN 65	AO 32
5	DN 80	AO 40
6	DN 100	AO 45
7	DN 65	AO 22
8	DN 100	AO 40
9	DN 80	AO 32
10	DN 65	AO 16
11	DN 100	AO 32
12	DN 80	AO 22
13	DN 80	AO 16
14	DN 100	AO 22
15	DN 100	AO 16

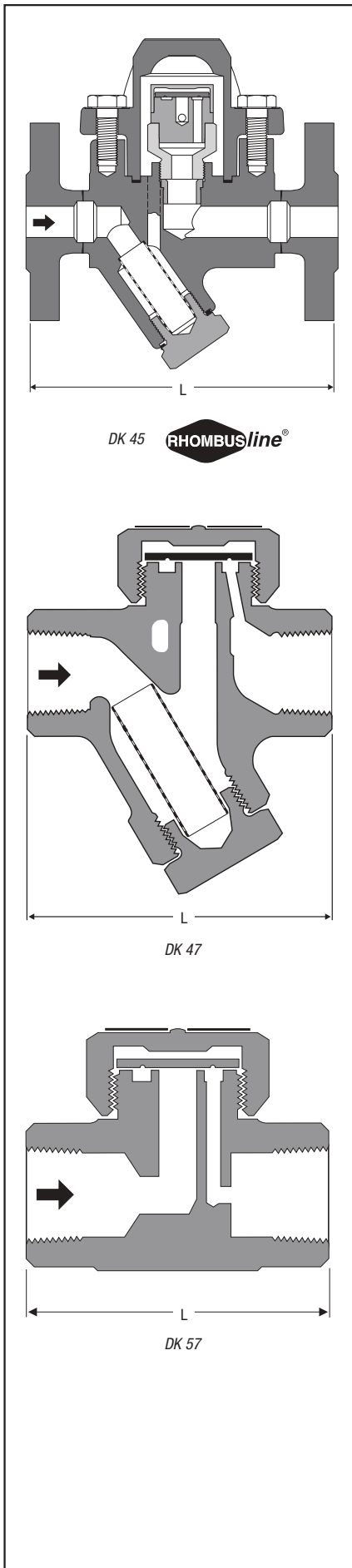

Features of the DK series

- Discharge with virtually no banking-up
- Robust, insensitive regulator
- Installation in any position
- Max. admissible back pressure 80 % of the upstream pressure

Application

Type		
DK 45		Rhombusline body with enclosed, weather-resistant regulator for discharging steam lines and tracing systems without banking-up of condensate
DK 47-L DK 57-L		Compact steam trap for small condensate flowrates for discharging steam lines and tracing systems without banking-up of condensate
DK 47-H DK 57-H		Compact steam trap for large condensate flowrates for discharging steam lines and tracing systems without banking-up of condensate

Pressure/Temperature Ratings

Type	PN / Class	Δ PMX [bar]	Material		Pressure/Temp. Rating ¹⁾			
			EN	ASTM	PMA [bar]	TMA [°C]	p/T [bar/°C]	
DK 45	PN 40	32	1.0460	A105	40.0	450	27.6 / 300 13.1 / 450	
DK 47	PN 63 / Class 600	42	1.4027 ²⁾	A743-CA40	63.0	400	50.0 / 300 42.0 / 400	
DK 57	PN 63 / Class 600	42	1.4021 ²⁾	AISI420	63.0	400	50.0 / 300 42.0 / 400	

- ¹⁾ Limits for body/cover. Functional requirements may restrict the use to below the limits quoted.
For full details on limiting conditions depending on end connection and type of regulator see data sheet.
- ²⁾ ASTM nearest equivalent is stated for guidance. Physical and chemical properties comply with EN.

Available End Connections and Overall Length

Type	Connections	Overall length (L) in mm			
		DN 10 3/8"	DN 15 1/2"	DN 20 3/4"	DN 25 1"
DK 45	Flanged EN PN 40	–	150	150	160
	Flanged ASME 150 ¹⁾	–	150	150	160
	Flanged ASME 300 ¹⁾	–	150	150	160
	Screwed sockets	–	95	95	95
	Socket-weld (SW)	–	95	95	95
	Butt-weld (BW)	–	200	200	200
DK 47-L	Screwed sockets	78	78	90	95
DK 47-H	Screwed sockets	–	78	90	95
DK 57-L	Screwed sockets	55	65	80	–
DK 57-H	Screwed sockets	–	70	80	90

¹⁾ DK 45 with flanged ASME: Overall length 172 mm on request.

Capacity Charts

The charts show the maximum hot condensate capacities.

DK 45

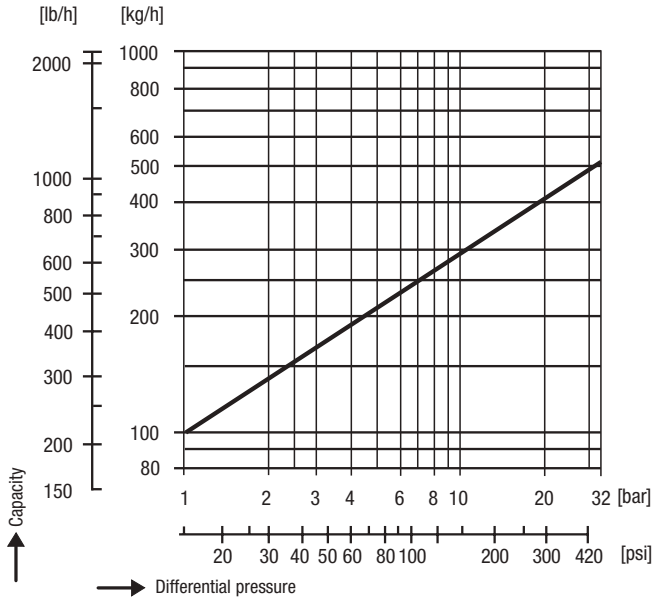

DK 47

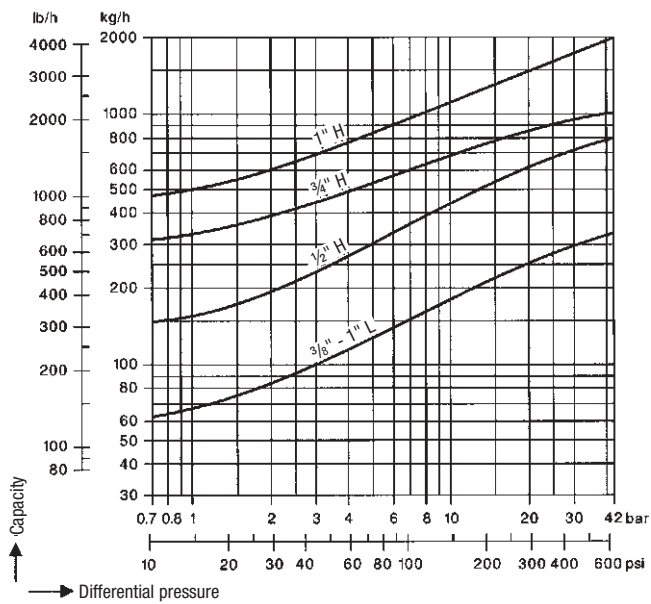

DK 57

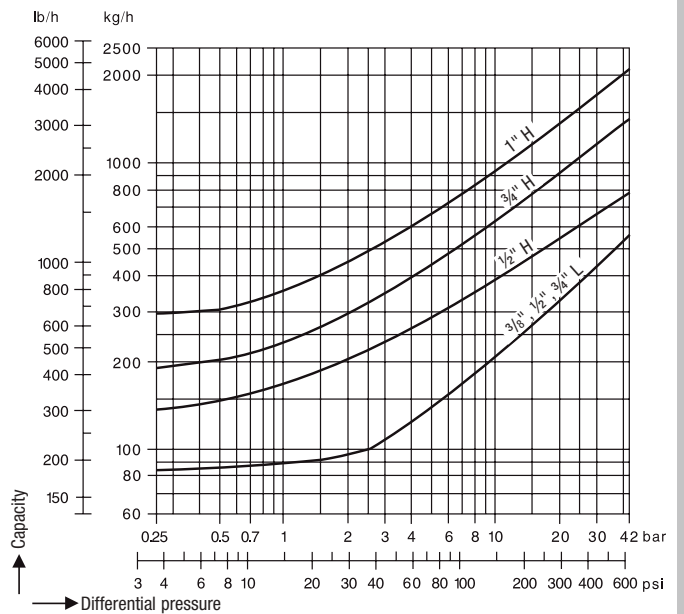

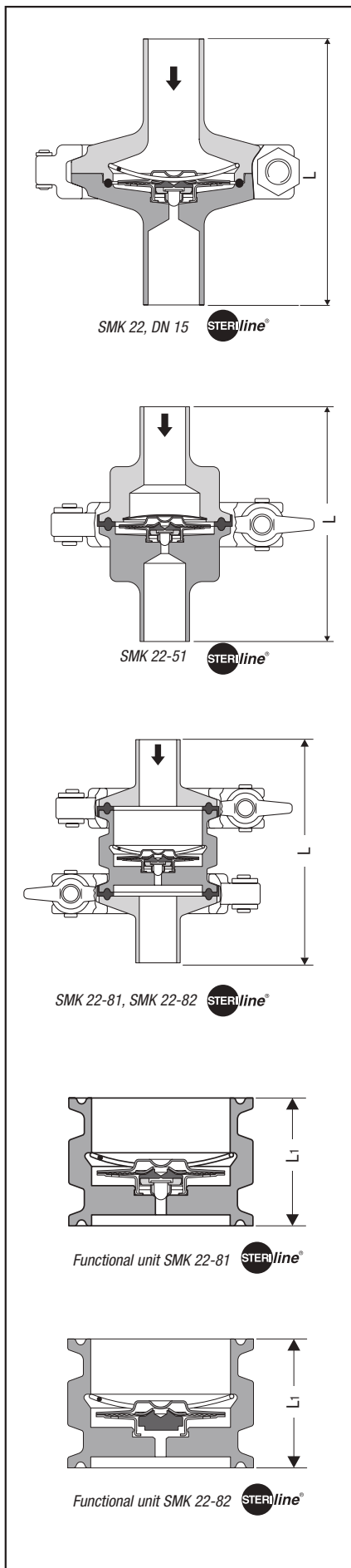

Application

Type	
SMK 22 STERline®	Virtually pocket-free For small and medium condensate flowrates. Internal surface roughness Ra ≤ 0.8 µm machine faced, optionally up to Ra ≤ 0.4 µm electropolished.
SMK 22-51 STERline®	Virtually pocket-free For small and medium condensate flowrates. Internal surface roughness Ra ≤ 0.8 µm machine faced, optionally Ra ≤ 0.6 µm plasma polished.
SMK 22-81 STERline®	Virtually pocket-free For small and medium condensate flowrates. Functional unit easy to exchange. Internal surface roughness Ra ≤ 0.8 µm machine faced, optionally Ra ≤ 0.6 µm plasma polished.
SMK 22-82 STERline®	Virtually pocket-free For medium and large condensate flowrates. Functional unit easy to exchange. Internal surface roughness Ra ≤ 0.8 µm machine faced, optionally Ra ≤ 0.6 µm plasma polished.
Functional unit SMK 22-81 STERline®	Virtually pocket-free For small and medium condensate flowrates. Internal surface roughness Ra ≤ 0.8 µm machine faced, optionally Ra ≤ 0.6 µm plasma polished. Connection via socket for mounting between clamps DIN 32676-DN 40.
Functional unit SMK 22-82 STERline®	Virtually pocket-free For medium and large condensate flowrates. Internal surface roughness Ra ≤ 0.8 µm machine faced, optionally Ra ≤ 0.6 µm plasma polished. Connection via socket for mounting between clamps DIN 32676-DN 40.
SRK 22A	Virtually pocket-free Non-return valve for liquids, gases and steam. Connection via socket for mounting between clamps DIN 32676.

Pressure/Temperature Ratings

Type	PN / Class	Δ PMX [bar]	Material		Pressure/Temp. Rating ¹⁾			
			EN	ASTM	PMA [bar]	TMA [°C]	p/T [bar/°C]	
SMK 22	PN 10	6	1.4435	A276 316L ²⁾	10.0	185 ³⁾	10.0 / 20	6.0 / 185 ³⁾
SMK 22-51	PN 10	6	1.4404	A182 316L ²⁾	10.0	185 ³⁾	10.0 / 20	6.0 / 185 ³⁾
SMK 22-81	PN 10	6	1.4404	A182-316L ²⁾	10.0	185 ³⁾	10.0 / 20	6.0 / 185 ³⁾
SMK 22-82								
Functional unit SMK 22-81	PN 10	6	1.4404	A182-316L ²⁾	10.0	185 ³⁾	10.0 / 20	6.0 / 185 ³⁾
SMK 22-82								
SRK 22A	PN 10	–	1.4408 / 1.4571	A351 CF8M / AISI316Ti	10.0	185 ³⁾	10.0 / 20	6.0 / 185 ³⁾

¹⁾ Limits for body/cover. Functional requirements may restrict the use to below the limits quoted.
For full details on limiting conditions depending on end connection and type of regulator see data sheet.

²⁾ ASTM nearest equivalent is stated for guidance. Physical and chemical properties comply with EN.

³⁾ 185 °C with PTFE gasket, 150 °C with EPDM gasket.

Available End Connections and Overall Length

Type	Connections	Overall length (L) in mm						
		DN 10 3/8"	DN 15 1/2"	DN 20 3/4"	DN 25 1"	DN 32 1 1/4"	DN 40 1 1/2"	DN 50 2"
SMK 22	Butt-weld ends	83	83	83	83	–	–	–
	Clamp	65	65	65	65	–	–	–
SMK 22-51	Butt-weld ends	90	90	90	90	–	–	–
	Clamp	65	65	65	65	–	–	–
SMK 22-81	Butt-weld ends	96	96	96	96	–	–	–
Functional unit SMK 22-81 SMK 22-82	Socket for mounting between clamps DIN 32676-DN 40 L1 standard	–	–	–	35	–	–	–
SRK 22A	Socket for mounting between clamps DIN 32676	–	23	29.5	33.5	38	43	54

Capacity Charts

SMK 22, SMK 22-51, SMK 22-81, SMK 22-82

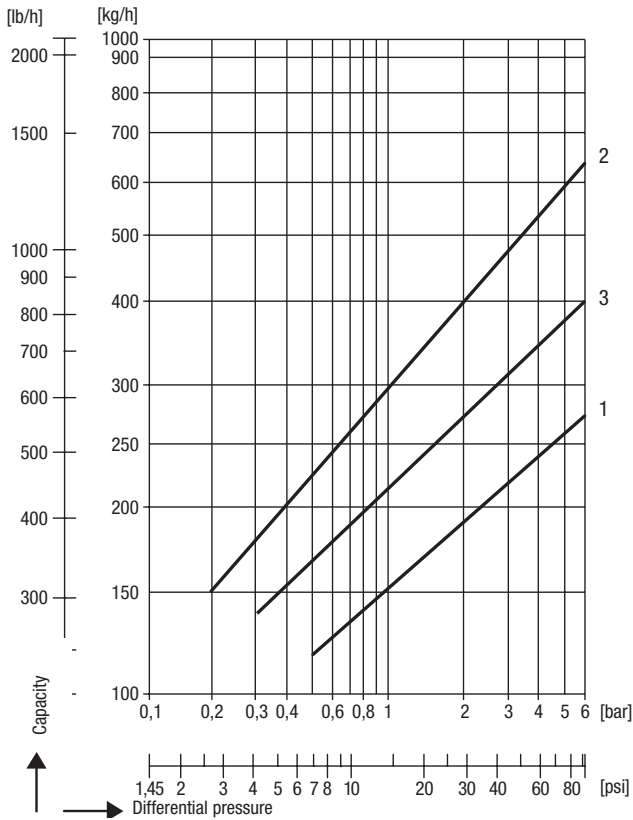

The chart shows the maximum capacities for hot and cold condensate.

Curve 1 SMK 22, SMK 22-51, SMK 22-81

This curve indicates the max. capacity of hot condensate that the steam trap with regulating membrane *Steriline* can discharge with virtually no banking-up.

Curve 2 SMK 22, SMK 22-51, SMK 22-81, SMK 22-82

This curve shows the max. capacity of cold condensate that the steam trap can discharge (20 °C at start-up).

Curve 3 SMK 22-82

This curve indicates the max. capacity of hot condensate that the steam trap with regulating membrane *Steriline* can discharge with virtually no banking-up.

Other steam traps and non-return valves for sterile and aseptic applications:

- MK 45A-1 and MK 45A-2** see pages 8 – 9
- MK 36/51 and MK 36/52** see pages 8 – 9
- UNA 16A** see pages 10 – 12
- UNA 46A** see pages 10 – 12
- VKE stainless steel** see pages 28 – 29

- RK 86A** see pages 42 – 43
- RK 16A** see pages 44 – 45
- RK 26A** see pages 44 – 45

SRK 22A

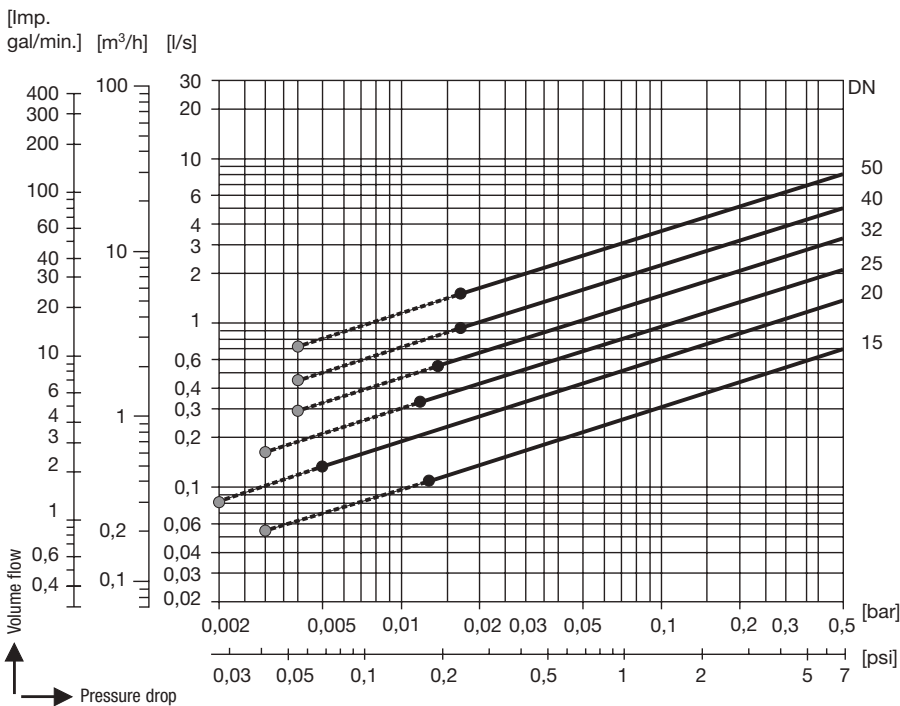

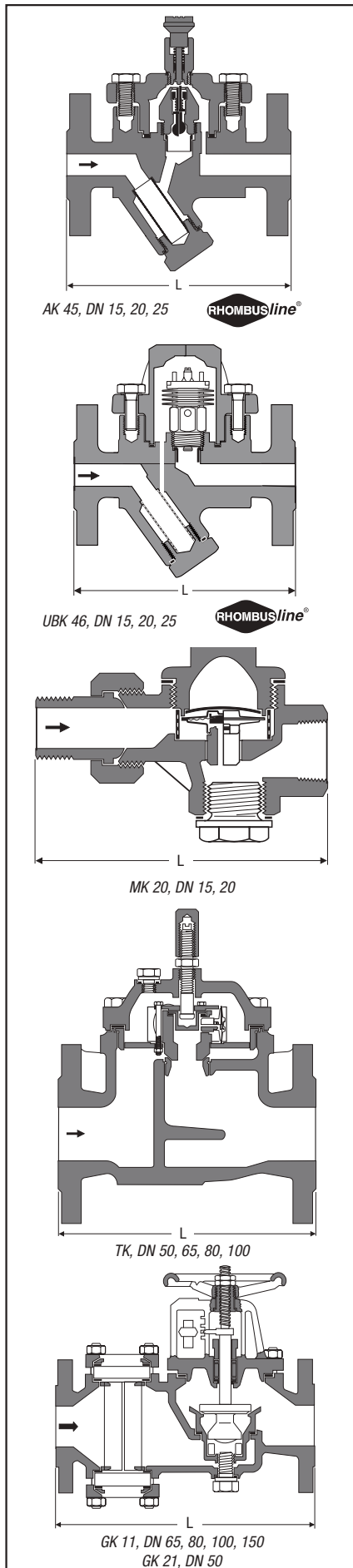

Application

Type	
AK 45 RHOMBUSline®	Condensate drain valve for discharging condensate from steam systems during start-up and draining residual condensate at shut-down, with integral Y-type strainer and hand purging knob. Factory-set closing pressure 0.8 bar.
UBK 46 RHOMBUSline®	Steam trap with adjustable condensate discharge temperature, thereby suppressing the formation of flash steam. With Y-type strainer.
MK 20	Steam trap for low-pressure steam-heating installations.
TK 23, TK 24	Steam trap with thermostatic pilot control using thermostatic capsules for the discharge of very large condensate flowrates with relatively continuous condensate formation.
GK 11¹⁾	Thermodynamic steam trap with stage nozzle for the discharge of very large condensate flowrates. With integral Vaposcope (sightglass) for optimum trap adjustment.

¹⁾ DN 50 mm: GK 21

Pressure/Temperature Ratings

Type	PN / Class	Δ PMX [bar]	Material		Max. Pressure/Temperature Rating ¹⁾			p/T	
			EN	ASTM	PMA [bar]	TMA [°C]	[bar/°C]		
AK 45	PN 40	–	1.0460	A105	40.0	450	27.6 / 300	13.1 / 450	
UBK 46	PN 40	32	1.0460	A105	40.0	450	27.6 / 300	13.1 / 450	
MK 20	PN 6	4.5	5.4202	–	6.0	300	4.5 / 250	3.6 / 300	
TK 23	PN 16	5 / 10	5.1301	A126 Cl.B ²⁾	16.0	300	16.0 / 120	10.0 / 300	
TK 24	PN 25	5 / 14	1.0619	A216 WCB	25.0	400	19.4 / 200	14.2 / 400	
GK 11, GK 21	PN 10/16	6	5.1301	A126 Cl.B ²⁾	16.0 ³⁾	300	16.0 / 120 ³⁾	13.0 / 300 ³⁾	

¹⁾ Limits for body/cover. Functional requirements may restrict the use to below the limits quoted.

For full details on limiting conditions depending on end connection and type of regulator see data sheet.

²⁾ ASTM nearest equivalent is stated for guidance. Physical and chemical properties comply with EN.

³⁾ GK 11, DN 100/150, PN 10, max. 10 bar

Available End Connections and Overall Lengths

Type	Connection	Overall length (L) in mm								
		DN 10 3/8"	DN 15 1/2"	DN 20 3/4"	DN 25 1"	DN 50 2"	DN 65 2 1/2"	DN 80 3"	DN 100 4"	DN 150 6"
AK 45	Flanged EN PN 40	–	150	150	160	–	–	–	–	–
	Flanged ASME 150	–	150	150	160	–	–	–	–	–
	Flanged ASME 300	–	150	150	160	–	–	–	–	–
	Screwed sockets	–	95	95	95	–	–	–	–	–
UBK 46	Flanged EN PN 40	–	150	150	160	–	–	–	–	–
	Flanged ASME 150	–	150	150	160	–	–	–	–	–
	Flanged ASME 300	–	150	150	160	–	–	–	–	–
	Screwed sockets	–	95	95	95	–	–	–	–	–
	Socket-weld (SW)	–	95	95	95	–	–	–	–	–
MK 20¹⁾	Male/female thread	–	120	125	–	–	–	–	–	–
TK 23	Flanged EN PN 16	–	–	–	–	230	290	310	350	–
TK 24	Flanged EN PN 25	–	–	–	–	230	290	310	350	–
GK 11²⁾	Flanged EN PN 10/16	–	–	–	–	320	420	420	620	900

¹⁾ Straight-through or angle design (see representation)

²⁾ DN 50 mm: GK 21

Capacity Charts

The charts show the maximum hot condensate capacities. (Exception: AK 45 – cold water capacity.)

AK 45 Cold water capacity

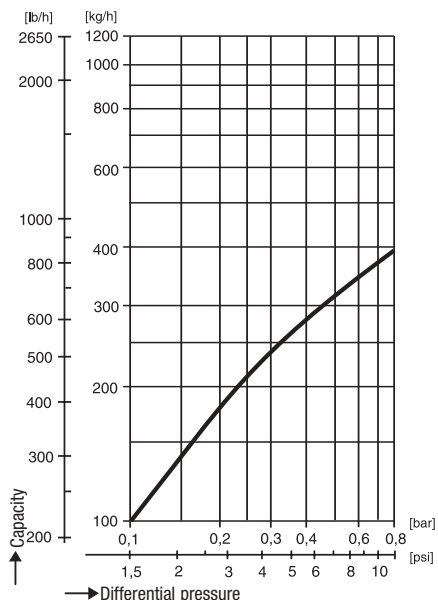

MK 20

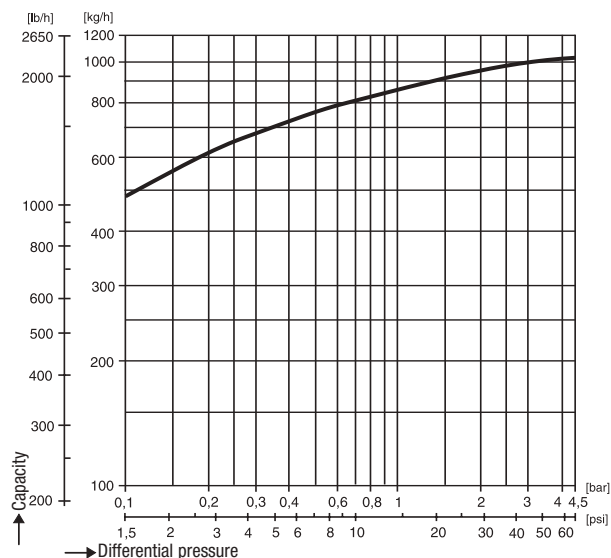

Capacities, opening temperatures UBK 46

Service pressure	[barg]	1	2	4	8	12	16	20	26	32
Factory-set opening temperature	[°C]	60	64	72	84	93	102	110	118	128
Capacity at t 10 K below opening temperature	[kg/h]	30	60	90	120	130	140	150	160	170
Cold water capacity at 20 °C (start-up capacity)	[kg/h]	250	320	480	760	1020	1280	1500	1780	2040

TK 23, TK 24

For differential pressures < 1 bar use capsule "OH2"
(max. service pressure 5 bar).

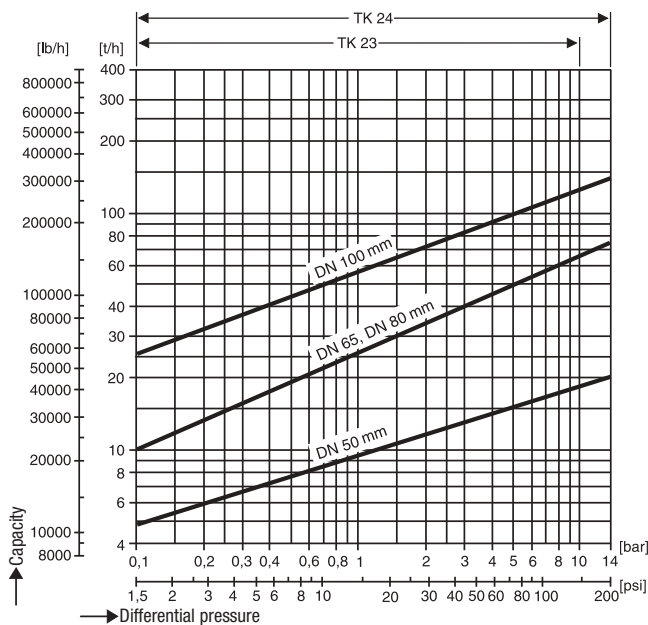

GK 11, GK 21

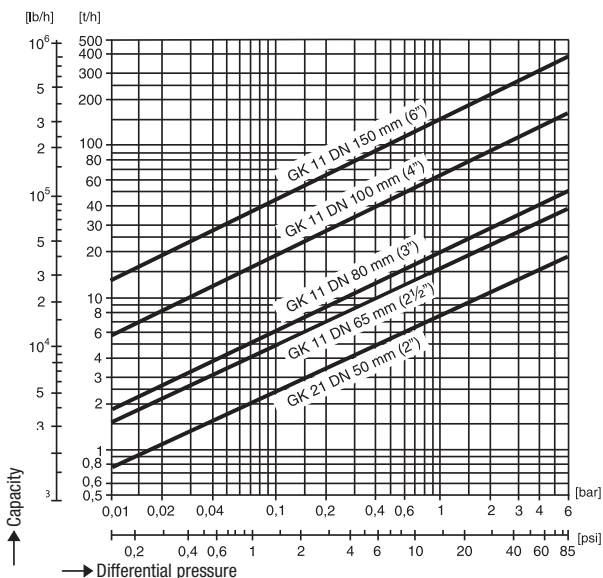

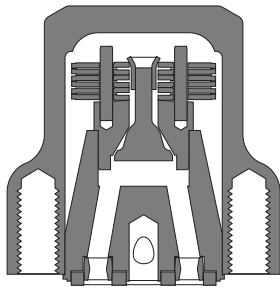

BK 36A/7

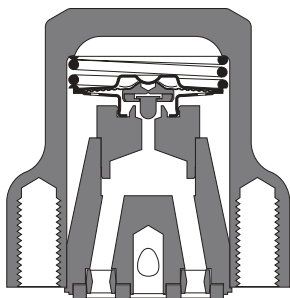

MK 36A/71

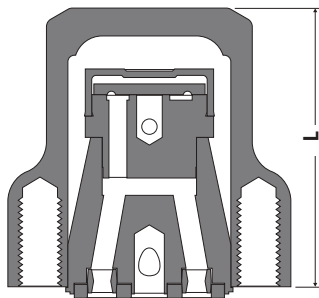

DK 36A/7

Features

- Maintenance-free, ultra-compact steam traps made from stainless steel, suitable for all UNIVERSAL (Swivel) connectors
- Installation in any position
- Integrated spiral wound gasket for connector
- Only two screws make for a quick and easy installation
- All steam trap units are optionally available with a UNIVERSAL connector (not fitted), e.g. UC 36, UCY 36 or TS 36.

Application

Type	
BK 36A/7	“Thermostatic/thermodynamic bimetallic” trap unit with corrosion-resistant Duo S.S. regulator unaffected by waterhammer, for condensate with virtually no banking-up and automatic air-venting of steam lines and tracing systems.
MK 36A/71 MK 36A/72	“Thermostatic capsule” trap unit with corrosion-resistant membrane regulator 5N1 unaffected by waterhammer, for condensate discharge with virtually no banking-up and automatic air-venting of steam lines and tracing systems.
DK 36A/7	“Thermodynamic” trap unit for condensate discharge with virtually no banking-up.
IB 16A-7	“Inverted bucket” trap unit for condensate discharge with no banking-up

Specification

Type	PN / Class	Δ PMX [bar]	Material		Pressure /Temperature ¹⁾			
			EN	ASTM	PMA [bar]	TMA [°C]	p/T [bar/°C]	
BK 36A/7	Class 300	32	1.4408	A351-CF8M	49.6	400	31.6 / 300	29.4 / 400
MK 36A/71, MK 36A/72	Class 300	32	1.4408	A351-CF8M	49.6	400	31.6 / 300	29.4 / 400
DK 36A/7	Class 300	32	1.4408	A351-CF8M	49.6	400	31.6 / 300	29.4 / 400
IB 16A-7	–	27.6	1.4306	A240-304L	–	425	–	28.0 / 425

¹⁾ Limits for body/cover. Functional requirements may restrict the use to below the limits quoted.
For full details on limiting conditions depending on end connection and type of regulator see data sheet.

Available Connections and Lengths

Type	Connection	Length L		
		1/2"	3/4"	1"
BK 36A/7; MK 36A/71; MK 36A/72; DK 36A/7	Universal connector	65	65	65
IB 16A-7	Universal connector	178	178	178

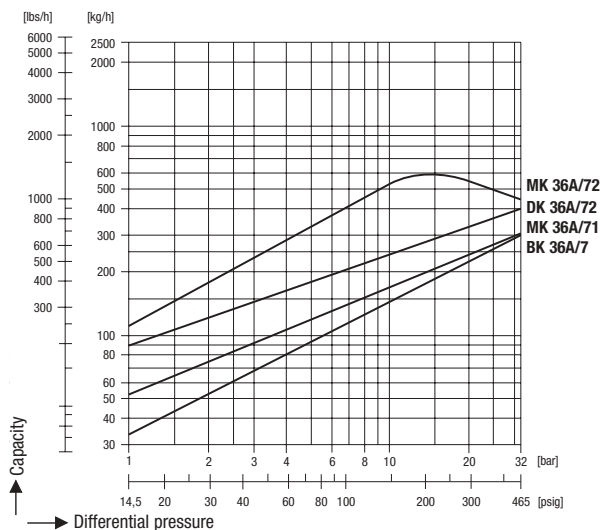

The chart shows the discharge capacity of hot condensate

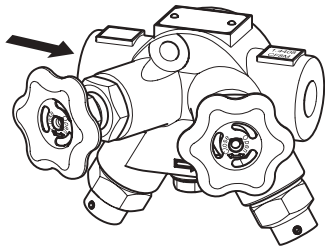

TS 36-1

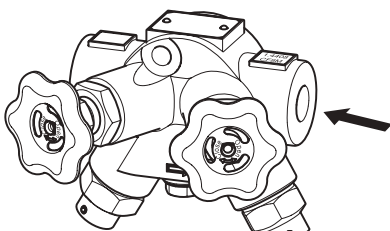

TS 36-2

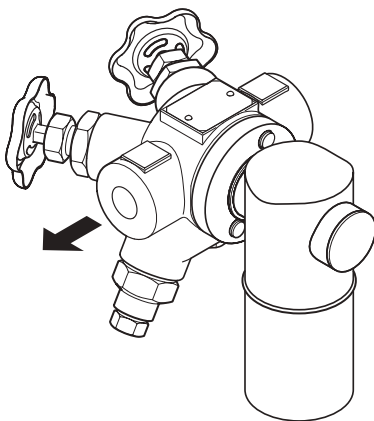

TS 36 with IB 16A-7

The compact-type Trap Station TS 36 features additional test and shut-off functions and is a more convenient alternative to the simpler connector units UC 36 and UCY 36.

When installed with a suitable steam trap with UNIVERSAL (Swivel) connector (sold separately) the equipment can discharge condensate from steam systems.

The two in-built **isolating valves** are designed to completely shut off the condensate inlet and outlet independently from each other.

The integral **blowdown valve** provides a means for cleaning the strainer and the **test valve** enables the steam trap operation to be checked.

The steam traps can be easily attached to and removed from the TS 36 by means of only two screws.

The following GESTRA connector steam traps can be used:

- Bimetallic steam trap BK 36A/7
- Steam trap with membrane capsule MK 36A/71
- Steam trap with membrane capsule MK 36A/72
- Thermodynamic steam trap DK 36A/7
- Inverted bucket steam trap IB 16A-7

Non-GESTRA swivel connector steam traps can also be fitted to the TS 36.

Schematic diagram

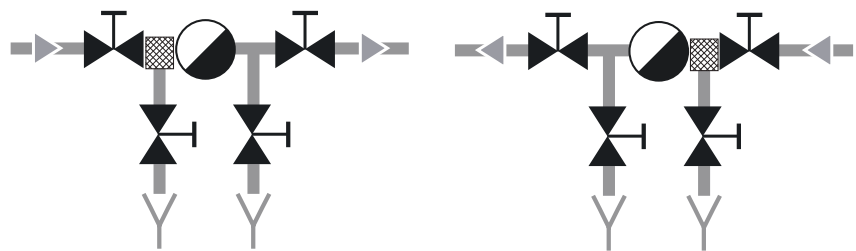

TS 36-1
Flow direction from left to right

TS36-2
Flow direction from right to left

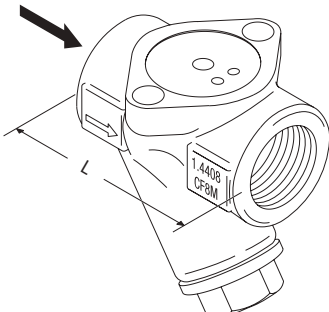

UCY 36

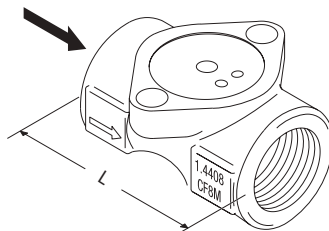

UC 36

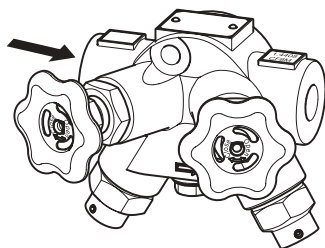

TS 36-1

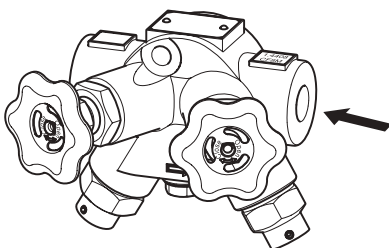

TS 36-2

Features

- Body / internals made from corrosion-resistant stainless steels
- UNIVERSAL (Swivel) connector for steam trap
- Connector unit can remain in pipeline during maintenance work
- Steam trap unit is easy to install and remove by means of only two screws

Application

Type	
UC 36	Universal connector
UCY 36	Universal connector with integrated strainer
TS 36-1	Compact-type connector unit with 2 isolating valves, test valve and strainer with blow-down valve. Coloured handwheels indicate inlet and outlet and assist in the correct installation. Flow direction from left to right.
TS 36-2	Compact-type connector unit with 2 isolating valves, test valve and strainer with blow-down valve. Coloured handwheels indicate inlet and outlet and assist in the correct installation. Flow direction from right to left.

Pressure/Temperature Ratings

Type UC 36, UCY 36, TS 36	ASME B 16.5 Class 300 (PN 50) Material Group 2.2)				
p (pressure) [bar]	49.6	42.2	35.7	31.6	29.4
T (temperature) [°C]	38	100	200	300	400
PMO (max. service pressure)	33.7 bar at 242 °C				

Based on ASME B 16.5, ASME B 16.34

Available Connections and Lengths

Type	Connection	Length L		
		1/2"	3/4"	1"
UC 36, UCY 36	Screwed sockets NPT Screwed sockets G	75	75	75
TS 36-1, TS 36-2	Socket-weld ends	120	120	on request

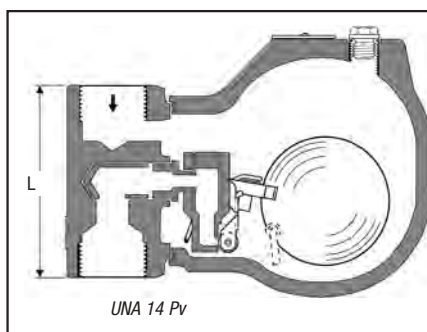

Features

- Liquid drainer for compressed air and gases with ball float and rolling ball valve
- The trap is suitable for draining gas and compressed air systems
- Purging device and connection for air-balance pipe included as standard
- Internals made from corrosion-resistant stainless steels
- Closing unit for temperatures up to 40 °C with rolling ball made from Perbunan, up to 120 °C with rolling ball made from stainless steel
- Body convertible for horizontal / vertical flow and left to right / right to left.

Specification

Type	PN / Class	ΔPMX [bar]	Material		Pressure / Temperature ¹⁾		
			EN	ASTM	PMA [bar]	TMA [°C]	p/T [bar/°C]
UNA 14Ph, UNA 14Pv with S.S. valve ball	PN 25	16	5.3103	–	25.0	120	25.0 / 20 25.0 / 120
UNA 14Ph, UNA 14Pv with Perbunan valve ball	PN 25	16	5.3103	–	25.0	40	25.0 / 20 25.0 / 40

¹⁾ Limits for body/cover. Functional requirements may restrict the use to below the limits quoted.
For full details on limiting conditions depending on end connection and type of regulator see data sheet.

Available End Connections and Overall Length

Type	Connection	Overall length L in mm		
		DN 15 1/2"	DN 20 3/4"	DN 25 1"
UNA 14 Ph	Screwed sockets ³⁾	95	95	95
	Flanged EN PN 25	150	150	160
UNA 14 Pv	Screwed sockets ³⁾	95	95	95
	Flanged EN PN 25	150	150	160

³⁾ Screwed sockets BSP to EN ISO 228-1 or screwed sockets NPT

Capacity Chart

UNA 14P

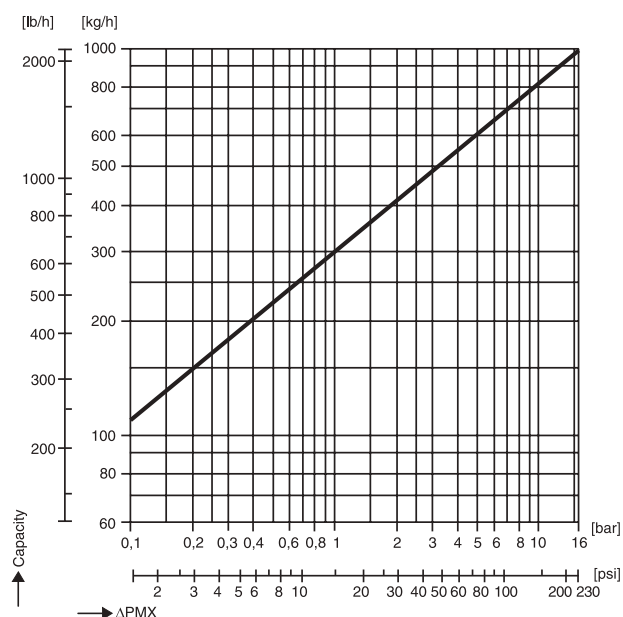

Hints on Installation

The condensate/distillate must be free to fall towards the trap. Isolating valves in horizontal lines lead to the formation of water pockets. In this case an air-balance pipe is required (see drawing).

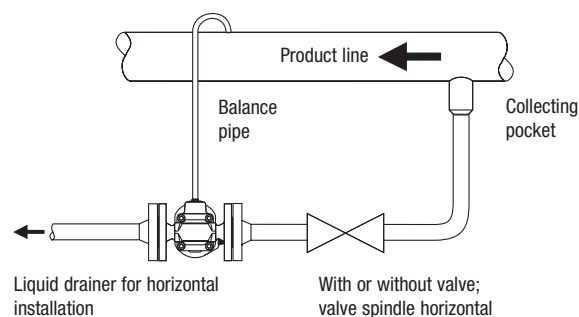

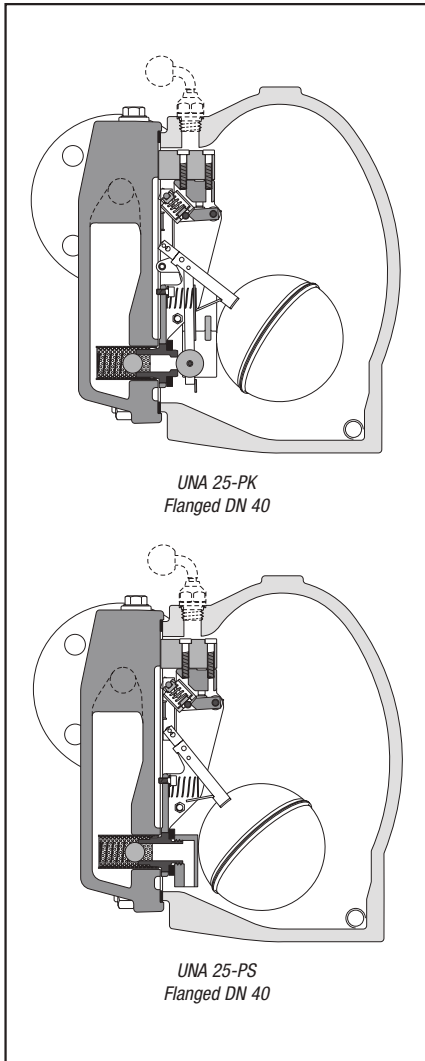

Description

UNA 25-PK:

Ball-float operated steam trap with pumping function. The equipment works primarily as a steam trap. The integral automatic pump function ensures efficient condensate discharge even if the steam pressure is low or the back pressure high.

UNA 25-PS:

Float-operated condensate lifter, designed for effective return of condensate. Steam is used as motive power to displace condensate out of the body.

Features

- Integrated inlet and outlet check valves.
- Rolling ball valve (UNA 25-PK) for tight shut-off even with low condensate flowrates.
- Float-controlled compact changeover unit for controlling motive steam and deaeration.

Specification

Type	PN / Class	Material		Pressure/Temperature ¹⁾				p/T	
		EN	ASTM ²⁾	PMA [bar]	TMA [°C]	PMO [bar]	PMOB [bar]	[bar/°C]	
UNA 25-PK	PN 40	5.3103	–	40.0	350	6.0 / 13.0	3.0 / 5.0	31.6 / 250	25.0 / 350
UNA 25-PK	Class 150	5.3103	A 395	17.2	350	6.0 / 13.0	3.0 / 5.0	12.1 / 250	6.6 / 350
UNA 25-PS	PN 40	5.3103	–	40.0	350	13.0	5.0	31.6 / 250	25.0 / 350
UNA 25-PS	Class 150	5.3103	A 395	17.2	350	13.0	5.0	12.1 / 250	6.6 / 350

¹⁾ Limits for body/cover. Functional requirements may restrict the use to below the limits quoted.

For full details on limiting conditions depending on end connection and type of regulator see data sheet.

²⁾ ASTM nearest equivalent is stated for guidance. Physical and chemical properties comply with EN.

Available Connections and Lengths

Type	Connection	Length L in mm DN 40 [1½"]
UNA 25-PK UNA 25-PS	Flanged EN PN 40	230
	Flanged ASME 150	227
	Screwed G or NPT	227

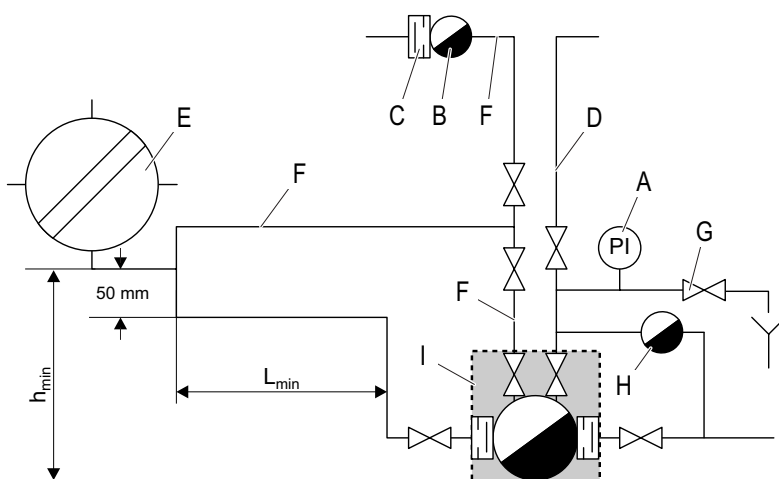

Key

- A Pressure gauge
 - B Thermostatic steam trap for air venting, e. g. MK
 - C Optional non-return valve in order to prevent air from entering if a vacuum is formed.
 - D Motive steam line (drained, DN 15)
 - E Heat exchanger
 - F Vent line, DN 15
 - G Pressure compensation valve
 - H Thermostatic steam trap for draining motive steam line, e. g. BK
 - I UNA 25-PK/UNA 25-PS
- L_{min} 2.5 m, DN 40
 h_{min} 0.5 m

Important Notes

The equipment must be hooked up to the pipes as shown in the graphical representation.

Please take the following items into consideration:

- A motive steam line must be available and connected (connection: female thread, G½)
- A vent line must be available and connected (connection: female thread, G½)
- Minimum filling head required between condensate outlet of the heat exchanger and the bottom of the equipment: 0.5 m.
- An inlet line (min. length 2.5 m) or buffer reservoir (volume: 3 l) is required.
- Maximum motive steam pressure, depending on design, is 6 or 13 barg.

Like any other industrial valve steam traps are subject to wear and their correct functioning can be impaired by precipitated solids and dirt deposits.

To assess the performance of a steam trap the following questions have to be answered:

- Does the steam trap work properly?
- If not, does the faulty trap cause loss of steam (leakage) or banking-up of condensate (obstructed discharge passage)?

Faulty steam traps are a major source of waste in a steam distribution system. A trap that is blowing live steam is the worst offender, but traps that are plugged or stuck closed can also be costly. The decreased plant efficiency due to loss of energy and additional make-up water results in lost production. Furthermore, an increase of pressure is liable to arise in condensate systems which will lead to difficulties at all locations where condensate is discharged. The magnitude of such a steam loss depends on the cross-sectional area of the leak and, at the same time, the amount of discharged condensate. Locations where only small amounts of condensate are formed and discharged, e. g. drainage points in steam lines and tracing systems, are particularly problematical. On the other hand, locations where relatively large amounts of condensate are discharged will not give rise to considerable loss of live steam because of the presence of a large volume of liquid.

Steam traps which are **obstructed or stuck closed** do not cause loss of energy and/or water but reduce – to a greater or lesser extent – the efficiency of heat-transfer equipment and steam users. And waterhammer caused by condensate banking-up leads to considerable physical damage in steam and condensate systems.

Experience shows that installations where no regular trap testing and servicing takes place have a failure rate of defective steam traps in the order of 15 – 25 %. Regular maintenance and trap testing, which should be carried out at least once a year, can strongly reduce the failure rate to 5 %.

Test Systems

Steam traps can be tested during operation by using **sightglasses**, **ultrasonic listening devices** or **level meters**.

Sightglasses (Vaposcopes Type VK 14, VK 16) provide an effective means of observing the flow of liquids in pipework. They are installed upstream of the traps, and allow the assessment of the traps by making their operation visible.

Level meters use conductivity readings to monitor steam trap performance. A test chamber with an integral level electrode is installed upstream of the trap to detect any defective steam trap. The corresponding output signal is displayed by the **Remote Test Unit NRA 1-3x** (remote monitoring).

The system **VKE** can monitor all types and makes of steam traps to detect loss of live steam. The correct operation of **RHOMBUS/line** steam traps type BK 45/46, MK 45, UBK 46 can be verified by using the compact-type level probes NRG 16-19, NRG 16-27 and NRG 16-28. The test station NRA 1-3x will evaluate the data coming from the system VKE.

Another way to test traps is to use an **ultrasonic listening device** which detects the sound produced by steam flowing through the traps. Depending on the test system used the sound sensed by the device is either graphically represented in the form of a curve (**VKP 41 plus**) or indicated by the deflection on the scale of a meter (**VKP 10**). When using the VKP 10, the field data specialist has to assess the indicator deflection and, consequently, the operation of the steam trap. The VKP 41, however, can directly track leaks associated with faulty steam traps and provides comprehensive reporting and a complete trap survey history.

Annual costs caused by steam loss / potential savings

Number of steam traps installed		<input type="text"/>
Annual failure rate <small>(Empirical value with first check approx. 15 – 25 %)</small>		<input type="text"/>
A	Number of defective steam traps	<input type="text"/>
B	Steam loss per steam trap (kg/h)	<input type="text"/>
C	Annual operating hours	<input type="text"/>
D	Annual steam loss (kg)	<input type="text"/> A x B x C = <input type="text"/>
E	Cost of steam per ton	<input type="text"/>
F	Annual loss in EURO	<input type="text"/> D / 1000 x E = <input type="text"/>
G	CO₂ saved per year (kg)	<input type="text"/> D x 0,16* = <input type="text"/>

*) Results may vary as a function of the fuel used for generating steam and condensate return.

Example

A	Number of defective steam traps	20
B	Steam loss per steam trap	3 kg/h
C	Annual operating hours	8000 h
D	Annual steam loss	480,000 kg
E	Cost of steam per ton	30.00 Euro/t
F	Annual loss	14,400.– Euro
G	CO₂ saved per year	76,800 kg

By the way:
A new steam trap costs – depending on the end connection – only approx. € 200 to € 250.

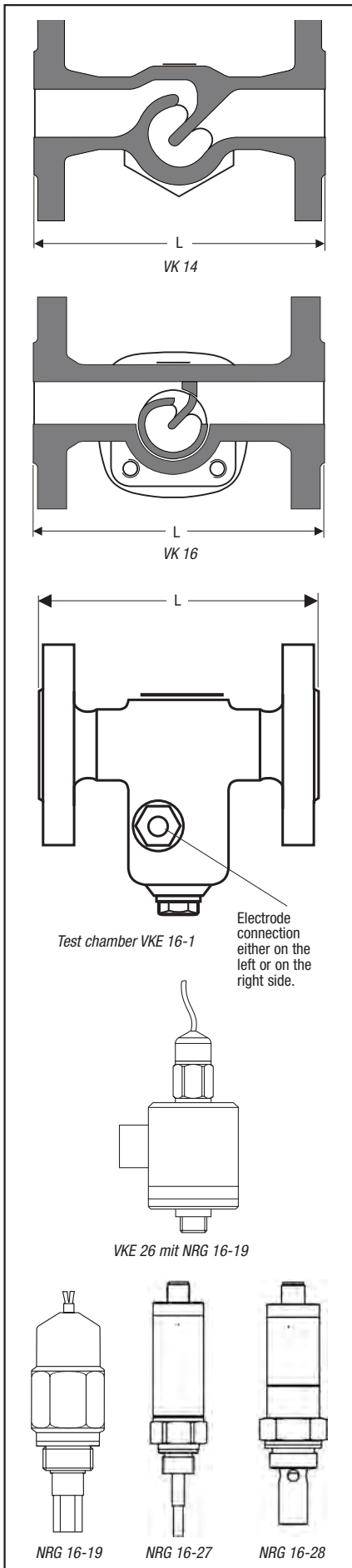

Application

Type	
Vaposcope VK 14, VK 16	Sightglass with borosilicate glass for checking heat exchangers and steam traps (installation upstream of traps). Visual supervision of flow conditions in condensate lines.
VKE 16-1, VKE 16A	Test chamber for measuring electrode for monitoring steam traps (installed upstream of the steam trap) to detect steam loss or banking-up of condensate (VKE 26) . For installation in horizontal lines or mounting at steam traps (VKE 26).
Vapophone VKP 10	Ultrasonic detector for detecting steam leakage in steam systems; for monitoring steam traps and stop valves.
TRAPtest VKP 41 plus VKP 41 plus Ex	Computer-based monitoring, recording and evaluation system for steam traps of all types and makes to detect loss of steam and condensate banking up.
NRG 16-19 NRG 16-27 NRG 16-28	Measuring electrode for installation in the test chamber VKE or in the body of Rhombusline steam traps. Designed for detecting loss of live steam/banking-up of condensate (used in conjunction with test unit NRA 1-3 or teststation NRA 1-3 CANbus). Response sensitivity 1.0 µS/cm.

Vaposcope VK

The Vaposcope can be installed in horizontal and vertical lines (without conversion). Installation in **flow direction upstream of steam trap**. The application of the VK 14 is limited to fluids with pH 9. The VK 16 is fitted with mica disks as standard for applications up to pH 10.

Test Set VKE

Consisting of: test chamber **VKE 16-1 / VKE 16A** or **VKE 26** with integrated measuring electrode NRG 16-19 or NRG 16-27 for all condensate discharge systems and types.

Test station NRA 1-3 or teststation NRA 1-3 CANbus for remote monitoring. Simultaneous and continuous monitoring of up to 16 steam traps to detect steam loss or banking-up of condensate. VKE 26: use in conjunction with float ball steam traps.

Pressure/Temperature Ratings

Type	PN / Class	Material		Pressure/Temperature ¹⁾			
		EN	ASTM	PMA [bar]	TMA [°C]	p/T [bar/°C]	
VK 14	PN 16	5.1301	A126 Cl.B ²⁾	16.0	280	12.8 / 200	9.6 / 280
VK 16	PN 40	1.0460	A 105	40.0	300	30.4 / 250	27.6 / 300
VKE 16-1	PN 40	1.0619	A216 WCB	40.0	400	28.4 / 250	23.1 / 400
VKE 16A STAINLESS STEEL	PN 40	1.4571	TP 316 Ti ²⁾	40.0	238	40.0 / 20	32.0 / 238
VKE 26	PN 40	1.0460	A105 ²⁾	40.0	400	28.4 / 250	23.1 / 400
NRG 16-19, NRG 16-27, NRG 16-28	PN 40	1.4571	AISI 316 Ti	40.0	238	40.0 / 20	32.0 / 238

¹⁾ Limits for body/cover. Functional requirements may restrict the use to below the limits quoted.

For full details on limiting conditions depending on end connection and type of regulator see data sheet.

²⁾ ASTM nearest equivalent is stated for guidance. Physical and chemical properties comply with EN.

Available Connections and Overall Lengths

Type	Connection	Overall length L in mm				
		DN 15 1/2"	DN 20 3/4"	DN 25 1"	DN 40 1 1/2"	DN 50 2"
VK 14	Flanged EN PN 16	130	150	160	200	230
VK 16	Flanged EN PN 40	150	150	160	230	230
	Flanged ASME 150	150	150	160	230	230
	Flanged ASME 300	150	150	160	230	230
	Screwed sockets	95	95	95	130	230
	Socket-weld	95	95	95	130	230
VKE 16-1	Flanged EN PN 40	150	150	160	–	–
	Flanged ASME 150	150	150	160	–	–
	Flanged ASME 300	150	150	160	–	–
	Screwed sockets	95	95	95	–	–
	Socket-weld	200	200	200	–	–
VKE 16 A	Flanged EN PN 40	160	160	160	200	230
VKE 26	External/internal thread 3/8" BSP					
NRG 16-19	External thread 3/8" BSP	Nominal length = 31 mm				
NRG 16-27		with integrated Pt 1000 thermocouple				
NRG 16-28	External thread M 24 x 1.5 for installation in the bodies of Rhombusline steam traps with integrated Pt 1000 thermocouple					

System VKE

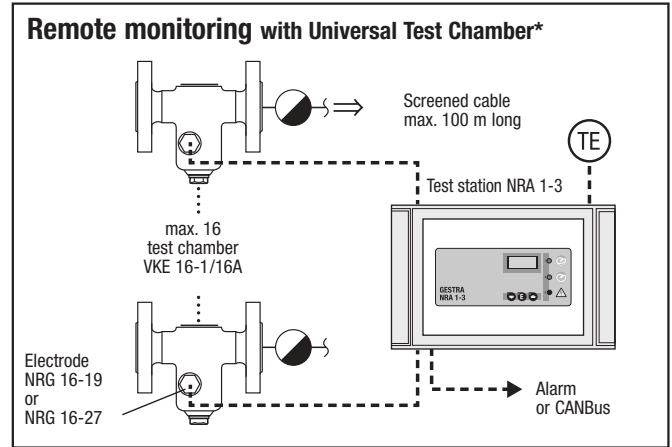
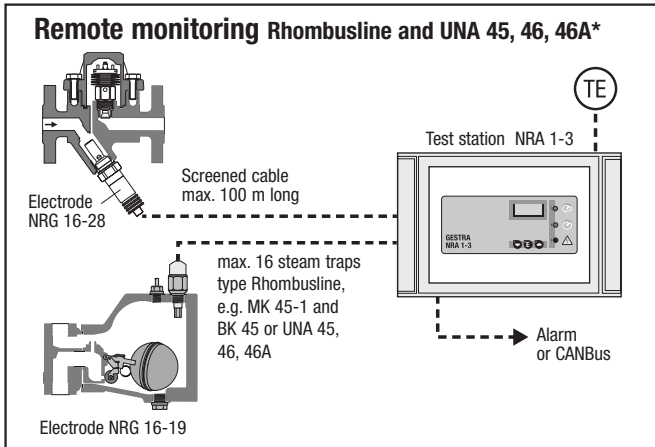

* Combination possible

Vapophone VKP 10

The VKP 10 is used to detect sound in the ultrasonic range as caused by steam flowing through a steam trap.

The ultrasonic vibrations are detected by a probe and converted into electric signals which are indicated on the meter of a measuring instrument.

Protection: IP 41

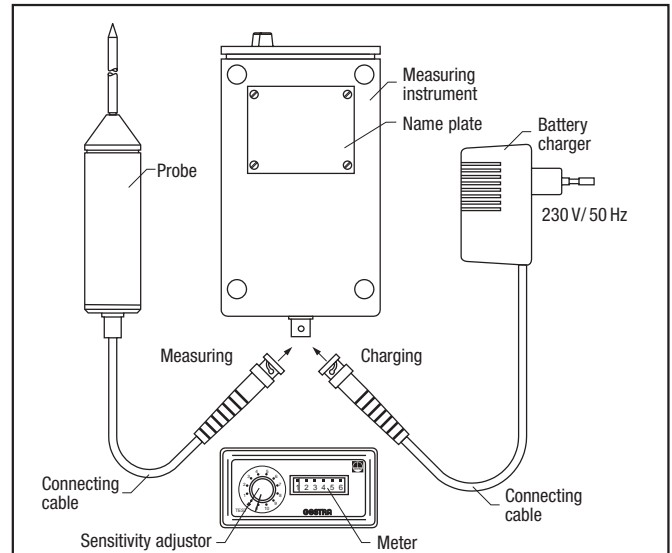

TRAPtest VKP 41 plus / VKP 41 plus Ex

Monitoring, recording and evaluation system **TRAPtest VKP 41 plus (VKP 41 plus Ex** for application in potentially explosive atmospheres) for checking steam traps of all types and makes for loss of live steam and banking-up of condensate. The equipment consists of a **data collector**, a **COM box** with **measuring probe** and a PC software program for managing steam trap data.

- For all types and makes of steam traps
- Automatic and objective evaluation of steam traps, no working knowledge of steam trap operation required
- Ultrasonic trap tester with integrated temperature sensor detects steam loss and blocked steam traps
- Graphical representation of collected data in form of curves
- Normal and quick check
- Data transfer via Bluetooth enables safe and user friendly operation
- Automatic language adaptation for over 20 languages
- Simple calculation of loss of steam in local currency
- Automatic calculation of CO₂ emissions
- Extensive data import and export functions
- Data collector: protection IP 68
- Bright, capacitance multi-touch colour display with wet finger and glove support
- Built-in camera and phone
- VKP 41plusEX for application in hazardous areas



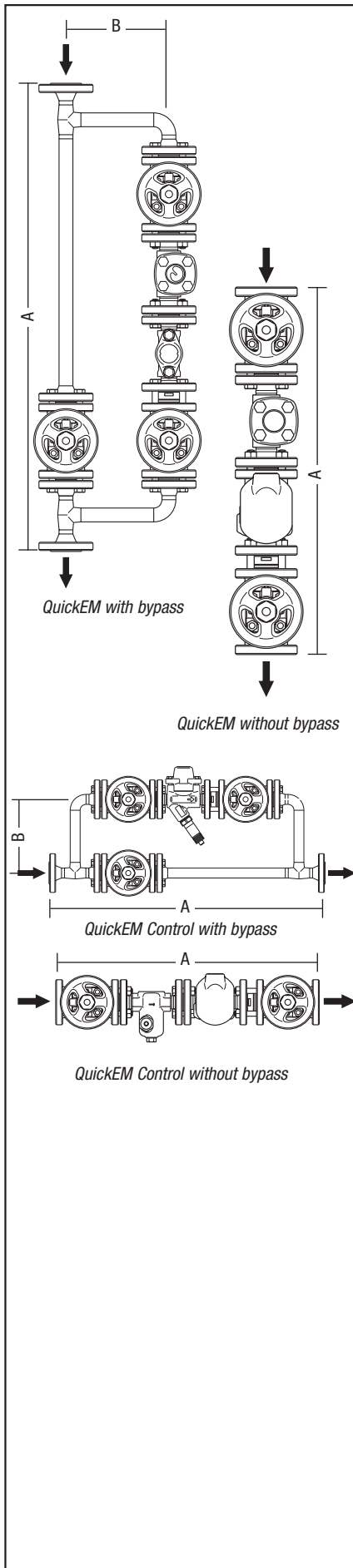

Description

GESTRA Drain Modules QuickEM are completely interconnected units for horizontal or vertical installation with or without bypass. They come with valves and steam traps, non-return valves, sightglass and shut-off valves as well as all necessary pipes, fittings, flanges, gaskets and screws. Note that counterflanges, bolts and seals are not part of the supply. GESTRA Drain Modules QuickEM Control are used for monitoring steam traps and an electrode is directly fitted into the steam trap or a test chamber.

Pressure & Temperature Limits / End Connections

QuickEM with and without bypass, flanges PN 16, EN 1092-1

Service pressure p	[barg]	16.0	14.4	12.8	11.2	9.6
Inlet temperature T	[°C]	20	100	200	250	280
pH value		≤ 9				
Δ PMX / Δ P (admissible differential pressure) [bar]		see data sheets for steam traps				

QuickEM with and without bypass, flanges PN 40, EN 1092-1

Service pressure p	[barg]	40.0	37.1	33.3	30.4	27.6
Inlet temperature T	[°C]	20	100	200	250	300
pH value		≤ 10				
Δ PMX / Δ P (admissible differential pressure) [bar]		see data sheets for steam traps				

QuickEM Control with and without bypass, flanges PN 16, EN 1092-1

Service pressure p	[barg]	16.0	14.4	12.8	11.2	9.6
Inlet temperature T	[°C]	20	100	200	238	238
Δ PMX / Δ P (admissible differential pressure) [bar]		see data sheets for steam traps				

QuickEM Control with and without bypass, flanges PN 40, EN 1092-1

Service pressure p	[barg]	40.0	37.1	33.3	30.4	27.6
Inlet temperature T	[°C]	20	100	200	238	238
Δ PMX / Δ P (admissible differential pressure) [bar]		see data sheets for steam traps				

Dimensions and Weights

QuickEM with bypass	DN 15				DN 20				DN 25				DN 40				DN 50			
	Dimensions [mm]		Weight [kg]		Dimensions [mm]		Weight [kg]		Dimensions [mm]		Weight [kg]		Dimensions [mm]		Weight [kg]		Dimensions [mm]		Weight [kg]	
	A*)	B	PN 16	PN 40	A	B	PN 16	PN 40	A	B	PN 16	PN 40	A	B	PN 16	PN 40	A	B	PN 16	PN 40
QuickEM BK ¹⁾	821/841	200	21	25	908	200	27	31	988	200	45	49	1290	300	83	82	1452	300	102	101
QuickEM MK ¹⁾	821/841	200	21	25	908	200	27	31	988	200	45	49	1290	300	83	82	1452	300	103	102
QuickEM UNA 14	821/841	200	26	–	908	200	33	–	988	200	51	–	–	–	–	–	–	–	–	–
QuickEM UNA 16	821/841	200	–	27	908	200	–	34	988	200	–	53	–	–	–	–	–	–	–	–
QuickEM UNA 45 ¹⁾	–	–	–	–	–	–	–	–	–	–	–	–	1290	300	97	–	1452	300	115	–
QuickEM UNA 46	–	–	–	–	–	–	–	–	–	–	–	–	1290	300	–	96	1452	300	–	114

QuickEM Control with bypass	DN 15				DN 20				DN 25				DN 40				DN 50			
	Dimensions [mm]		Weight [kg]		Dimensions [mm]		Weight [kg]		Dimensions [mm]		Weight [kg]		Dimensions [mm]		Weight [kg]		Dimensions [mm]		Weight [kg]	
	A	B	PN 16	PN 40	A	B	PN 16	PN 40	A	B	PN 16	PN 40	A	B	PN 16	PN 40	A	B	PN 16	PN 40
QuickEM Control BK ¹⁾	689	250	21	21	756	250	27	27	826	300	45	45	1320	400	81	80	1452	400	100	99
QuickEM Control MK ¹⁾	689	250	21	21	756	250	27	27	826	300	45	45	1320	400	81	80	1452	400	101	100
QuickEM Control UNA 14	841	200	27	–	908	200	33	–	988	200	51	–	–	–	–	–	–	–	–	–
QuickEM Control UNA 16	841	200	–	27	908	200	–	33	988	200	–	51	–	–	–	–	–	–	–	–
QuickEM Control UNA 45 ¹⁾	–	–	–	–	–	–	–	–	–	–	–	–	1090	400	88	–	1222	400	103	–
QuickEM Control UNA 46	–	–	–	–	–	–	–	–	–	–	–	–	1090	400	–	87	1222	400	–	102

QuickEM without bypass	DN 15				DN 20				DN 25				DN 40				DN 50			
	Dimensions [mm]		Weight [kg]		Dimensions [mm]		Weight [kg]		Dimensions [mm]		Weight [kg]		Dimensions [mm]		Weight [kg]		Dimensions [mm]		Weight [kg]	
	A*)	B	PN 16	PN 40	A	B	PN 16	PN 40	A	B	PN 16	PN 40	A	B	PN 16	PN 40	A	B	PN 16	PN 40
QuickEM BK ¹⁾	564/584	–	11	14	627	–	14	17	670	–	16	20	870	–	50	49	968	–	59	58
QuickEM MK ¹⁾	564/584	–	11	14	627	–	14	17	670	–	16	20	870	–	50	49	968	–	59	58
QuickEM UNA 14	564/584	–	16	–	627	–	20	–	670	–	23	–	–	–	–	–	–	–	–	–
QuickEM UNA 16	564/584	–	–	17	627	–	–	21	670	–	–	23	–	–	–	–	–	–	–	–
QuickEM UNA 45 ¹⁾	–	–	–	–	–	–	–	–	–	–	–	–	870	–	64	–	968	–	73	–
QuickEM UNA 46	–	–	–	–	–	–	–	–	–	–	–	–	870	–	–	63	968	–	–	72

QuickEM-Control without bypass	DN 15				DN 20				DN 25				DN 40				DN 50			
	Dimensions [mm]		Weight [kg]		Dimensions [mm]		Weight [kg]		Dimensions [mm]		Weight [kg]		Dimensions [mm]		Weight [kg]		Dimensions [mm]		Weight [kg]	
	A	B	PN 16	PN 40	A	B	PN 16	PN 40	A	B	PN 16	PN 40	A	B	PN 16	PN 40	A	B	PN 16	PN 40
QuickEM Control BK ¹⁾	432	–	11	11	475	–	14	14	508	–	16	16	900	–	46	46	968	–	55	55
QuickEM Control MK ¹⁾	432	–	11	11	475	–	14	14	508	–	16	16	900	–	47	47	968	–	56	56
QuickEM Control UNA 14	584	–	17	–	627	–	20	–	670	–	22	–	–	–	–	–	–	–	–	–
QuickEM Control UNA 16	584	–	–	17	627	–	–	20	670	–	–	22	–	–	–	–	–	–	–	–
QuickEM Control UNA 45 ¹⁾	–	–	–	–	–	–	–	–	–	–	–	–	668	–	50	–	736	–	56	–
QuickEM Control UNA 46	–	–	–	–	–	–	–	–	–	–	–	–	668	–	–	50	736	–	–	56

*) PN 16 / PN 40 ¹⁾ Not for QuickEM made from stainless steel. Other sizes available on request.

Capacity Chart

The charts show the maximum hot condensate capacities.

QuickEM, QuickEM-Control DN 15 – DN 25

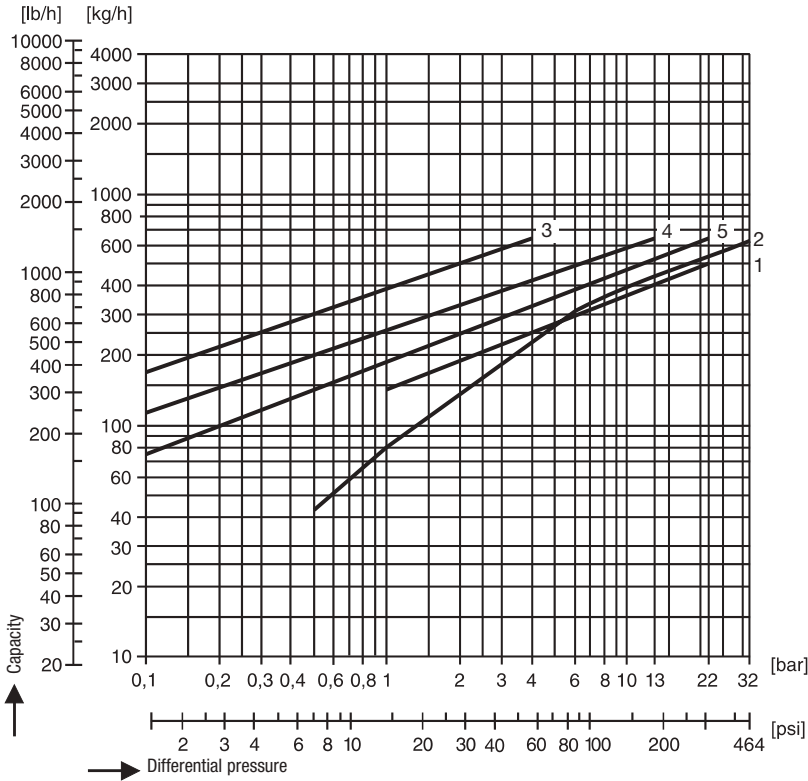

- UNA 14 DN 15-25 AO 4 (Curve 3)
- UNA 14 / UNA 16 DN 15-25 AO 13 (Curve 4)
- UNA 16 DN 15-25 AO 22 (Curve 5)
- BK 45 (Curve 1)
- MK 45-1 (Curve 2)

QuickEM, QuickEM-Control DN 40 – DN 50

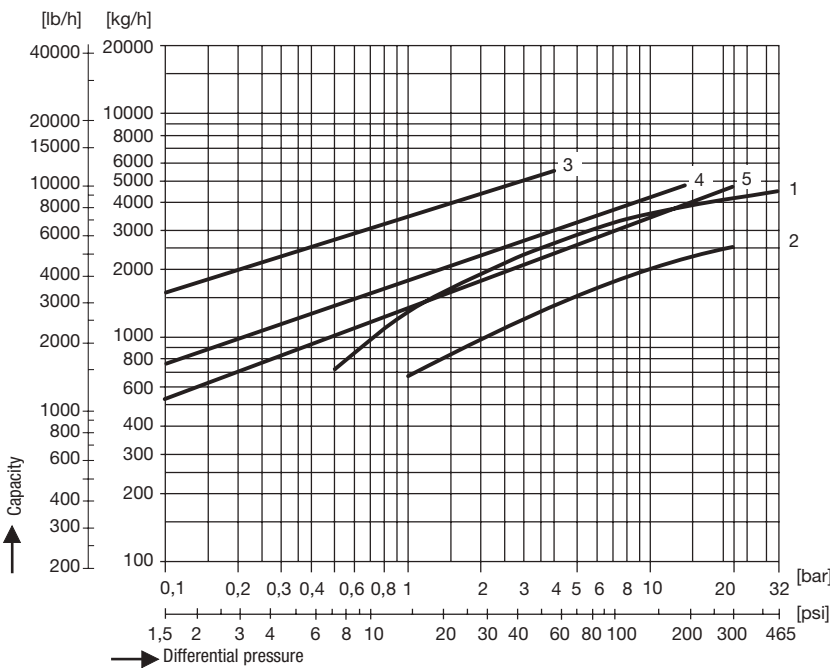

- UNA 45 / UNA 46 DN 40-50 AO 4 (Curve 3)
- UNA 45 / UNA 46 DN 40-50 AO 13 (Curve 4)
- UNA 46 DN 40-50 AO 22 (Curve 5)
- BK 15 (Curve 2)
- MK 25-2 (Curve 1)



Description

The connecting kits for sizes DN 15 to DN 65 and pressures PN 10 to PN 40 contain the following parts required for connecting flanged valves and steam traps to pipe flanges:

- Nuts
- Bolts
- Gaskets

With the content of one connecting kit you can attach the inlet and outlet side of a steam trap or valve to the pipe flange. Normally two gaskets, 8 nuts and 8 bolts are required for this purpose. However, for DN 65 a total of 16 nuts and 16 bolts are required.

The following nuts, bolts and gaskets are available:

Connecting kit	Bolts made of 1.7218		Gaskets to EN 1092 Graphite with perforated steel insert and inside seam 1.4571 for temperatures from -10 °C to 450 °C
	to EN 1515-1 for temperatures from -10 °C to 450 °C	to ISO 4032 for temperatures from -10 °C to 450 °C	
KIT 1 (DN 15 PN 10-40)	M 12 x 50 (8 pieces)	M 12 (8 pieces)	22 x 51 x 2 mm
KIT 2 (DN 20 PN 10-40)	M 12 x 55 (8 pieces)	M 12 (8 pieces)	27 x 61 x 2 mm
KIT 3 (DN 25 PN 10-40)	M 12 x 55 (8 pieces)	M 12 (8 pieces)	34 x 71 x 2 mm
KIT 4 (DN 40 PN 10-40)	M 16 x 60 (8 pieces)	M 16 (8 pieces)	49 x 92 x 2 mm
KIT 5 (DN 50 PN 10-16)	M 16 x 60 (8 pieces)	M 16 (8 pieces)	61 x 107 x 2 mm
KIT 6 (DN 50 PN 25-40)	M 16 x 65 (8 pieces)	M 16 (8 pieces)	61 x 107 x 2 mm
KIT 7 (DN 65 PN 10-16)	M 16 x 60 (16 pieces)	M 16 (16 pieces)	77 x 127 x 2 mm
KIT 8 (DN 65 PN 25-40)	M 16 x 70 (16 pieces)	M 16 (16 pieces)	77 x 127 x 2 mm

E-mail: info@de.gestra.com • Fax: +49 421 3503-393

Online: www.gestra.com/Service & Support/Questionnaire for preparing offers

Steam pressure / p₁ _____ bar

Steam temperature / T₁ _____ °C

Backpressure / p₂ _____ bar

Product outlet temperature / T_A _____ °C
(only for draining heat exchangers)

Condensate flowrate to be discharged _____ kg/h

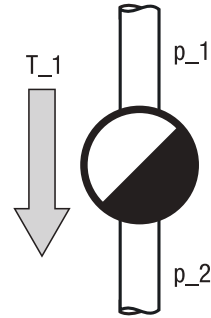

Fluid

Plant steam Pure steam _____

Nominal size _____ Pressure rating _____

End connection

EN flanges ASME flanges Butt-weld ends Socket-weld ends Screwed sockets G Screwed sockets NPT

Application

Draining pipes

Draining a heat exchanger

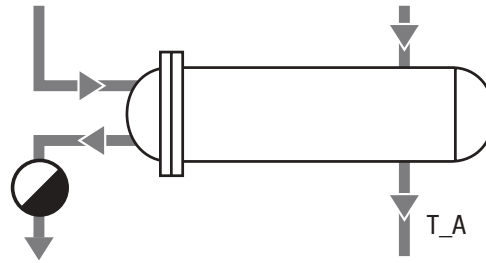
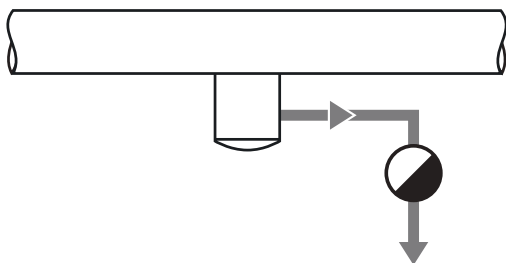

Required inspections/approvals: _____

Your details:

Company
Name / job title
Telephone
Fax
E-mail
Date

GESTRA Gravity Circulation Checks, DISCO Non-Return Valves and DISCO Swing Check Valves

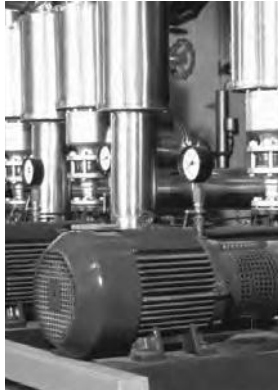

DISCO Non-Return Valves and DISCO Swing Check Valves

Page

Gravity Circulation Checks and DISCO Non-Return Valves
for sanitation applications and hvac systems.

Type SBO 11, Typ SBO 21, Typ SBO 31	37
Type MB 14	38 – 39
Type RK 70, Typ RK 71	38 – 39
Type RK 41, Typ RK 44	40 – 41

DISCO Non-Return Valves and DISCO Swing Check Valves for industrial applications.

Type RK 76	40 – 41
Type RK 86, Typ RK 86 A	42 – 43
Type BB...G, Typ BB...C, Typ BB...A	50 – 52
Type CB 14, Typ CB 26, Typ CB 26A	55 – 56
Type WB 26, Typ WB 26 A.....	57 – 58

DISCO Non-Return Valves and DISCO Swing Check Valves for special applications.

Type RK 16 A, Typ RK 16 C	44 – 45
Type RK 26 A.....	44 – 45
Type RK 49	46 – 47
Type RK 29 A	48 – 49
Type BB...GK	53 – 54
Type NAF-Check	59 – 60

DISCO Non-Return Valves and DISCO Swing Check Valves for marine applications

Type RK 44S	40 – 41
Type BB...GS	53 – 54
Type CB 24S.....	55 – 56
Type WB 24S.....	57 – 58

Questionnaire for preparing offers	61
--	----

The Lift Restriction for GESTRA Non-Return Valves

More efficient pumps and the requirement to minimize pressure loss in the installation often lead to oversized non-return valves.

As a consequence, the valve does not open completely, resulting in increased wear and, more often than not, annoying valve clattering.

Up till now the required volume flow of these non-return valves could only be adjusted in certain cases by selecting a different size or changing the place of installation.

The lift restriction for GESTRA valves provides stable low-noise operation even with small flowrates.

For users who do not want to change their pipe layout or use smaller sizes but require a more stable operating mode we now offer a retrofitting set consisting of a stroke limiter and a spring cap. This mechanism reduces the volume flow for the necessary full opening as a function of the valve size by approx. 40 %.

The lift restriction is available for non-return valves RK 41, RK 44, RK 86 and RK 86A in sizes DN 15 up to DN 100.



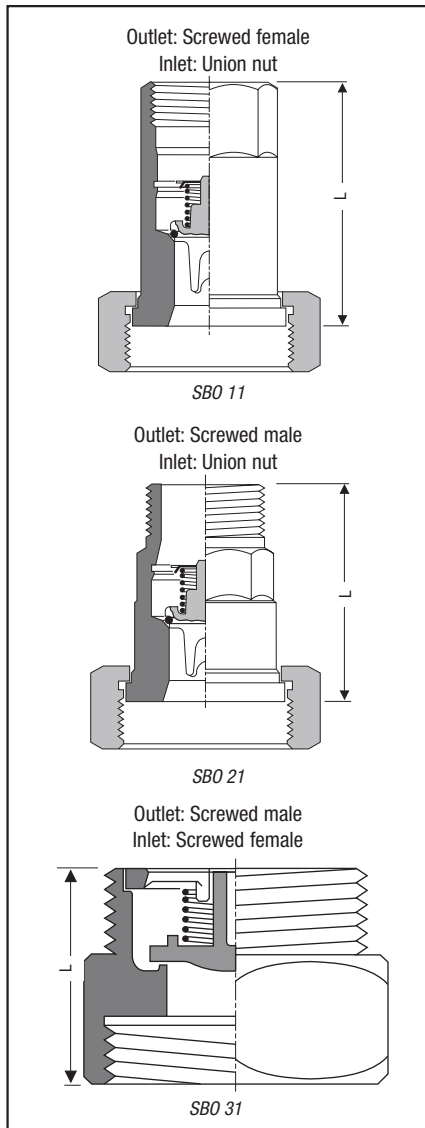

Application and Features

Type	PN	Application	Features
SBO	PN 6	Installed downstream of circulating pumps in heating and hot water installations in order to avoid gravity circulation	Plastic valve cone with advanced flow characteristic

Pressure/Temperature Ratings / Material

Max. service pressure [bar]	Max. service temperature [°C]	Materials	
		Body	Valve cone
6	130 ¹⁾	Brass	PPO

¹⁾ Max. service temperature at atmospheric pressure

Dimensions

Type	DN	SBO 11		SBO 21		SBO 31		
		L	[mm]	1"	1 1/4"	1"	1 1/4"	3/4"
Connections (BSP thread)	Inlet ²⁾	G 1 1/2	G 2	G 1 1/2	G 2	G 1 1/4	G 1 1/2	G 2
	Outlet	G 1	G 1 1/4	R 1	R 1 1/4			

²⁾ SBO 11 and SBO 21: Thread of union nut

Opening Pressures

Differential pressures at zero volume flow.

Type	DN	Opening pressure [mbar]			
		Direction of flow			
		with-out spring	with spring		
		↑	↑	→	↓
SBO 11	1" 1 1/4"	1	7	6	6
SBO 21	1" 1 1/4"	1	7	6	5
SBO 31	3/4" 1" 1 1/4"	2	9	7	5

Pressure Drop Charts

SBO 11, SBO 21

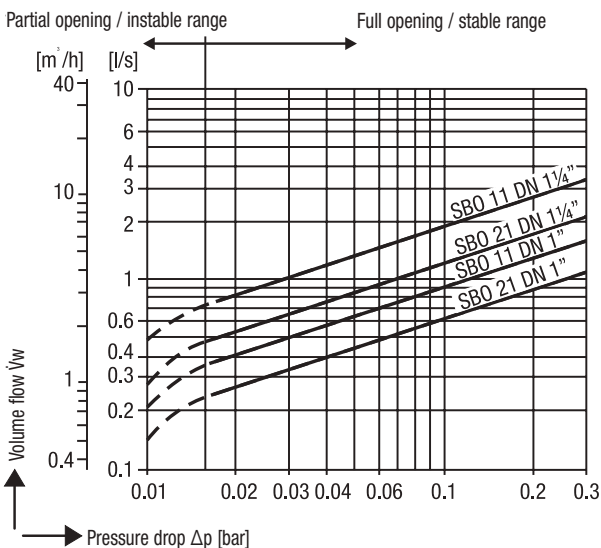

Curve 1: SBO 21 DN 1"
Curve 2: SBO 11 DN 1"

Curve 3: SBO 21 DN 1 1/4"
Curve 4: SBO 11 DN 1 1/4"

SBO 31

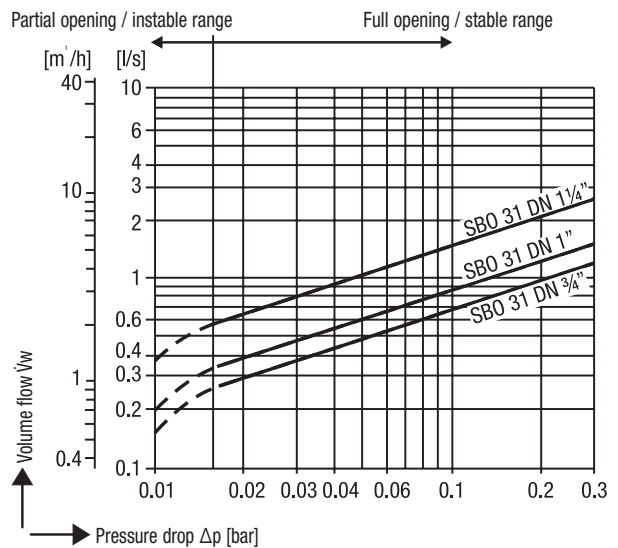

Curve 1: SBO 31 DN 3/4"
Curve 2: SBO 31 DN 1"

Curve 3: SBO 31 DN 1 1/4"

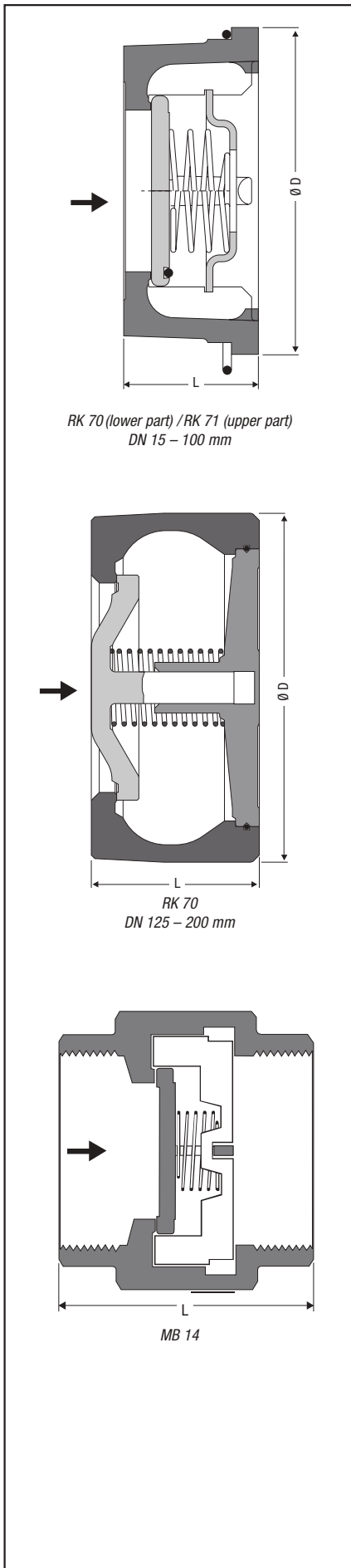

Application and Features

Type	PN	Application for liquids, gases and vapours	Features
RK 70	PN 6	suitable for heating and hot-water installations	Centric cone and spring guide, unaffected by dirt (DN 125-200)
RK 71	PN 16		Spiral centering ring for easy alignment between flanges
MB 14	PN 16		Screwed socket end connection

Body Material

Type		Nominal sizes DN	EN reference	ASTM equivalent ¹⁾
RK 70	Body	15 – 100 mm	Brass (CW617N)	Brass
	Valve disk		Plastic PPE	–
	Body	125 – 200 mm	Grey cast iron (5.1301)	A126 Class A
RK 71	Plug		Plastic Polyamid 6	–
	Body	15 – 100 mm	Brass (CW617N)	Brass
RK 71	Valve disk		1.4571	AISI 316 Ti
	Body	15 – 50 mm	Brass (CW614N)	Brass
MB 14	Valve disk		1.4571	AISI 316 Ti

¹⁾ ASTM material similar to EN material.
Observe different physical and chemical properties!

Dimensions

	DN	[mm]	15	20	25	32	40	50	65	80	100	125	150	200	
			[in]	1/2	3/4	1	1 1/4	1 1/2	2	2 1/2	3	4	5	6	8
			L	[mm]	16	19	22	28	31.5	40	46	50	60	90	106
RK 70	D	[mm]	40	47	56	72	82	95	115	132	152	184	209	264	
RK 71	D	[mm]	40	47	56	72	82	95	115	132	152	–	–	–	
MB 14	L	[mm]	49	49	61	61	72	72	–	–	–	–	–	–	
	D	[mm]	42	42	62	62	83	83	–	–	–	–	–	–	
	A.F.	[mm]	30	30	46	46	65	65	–	–	–	–	–	–	

Pressure/Temperature Ratings

Type	PN	DN	p / T / [bar] / [°C]		
RK 70	PN 6	15 – 100	6 / -10	3.0 / 50	2.0 / 80
	PN 6	125 – 200	6 / -10	1.5 / 100	0.5 / 130
RK 71	PN 16	15 – 100	16 / -10	16 / 180	13.5 / 200
MB 14	PN 16	G 1/2 – G 2	16 / -10	14 / 200	13 / 250

RK Designs

Type	Seat				without spring	Spring		Earthing connection
	metal-to-metal	EPDM	FPM	PTFE		special spring	Nimonic spring	
RK 70	(Plastic)	–	–	–	–	–	–	Use RK 86
RK 71	X	Use RK 41		Use RK 86	Use RK 41	–	–	
MB 14	X	–	–	–	–	–	–	–

X : standard
– : not available

Pressure Drop Charts

The curves given in the chart are valid for water at 20 °C. To read the pressure drop for other fluids the equivalent water volume flowrate must be calculated and used in the graph \dot{V}_w .

The values indicated in the chart are applicable for spring-assisted valves with horizontal flow and to valves without spring installed in vertical pipes with upward flow.

$$\dot{V}_w = \dot{V} \cdot \sqrt{\frac{\rho}{1000}}$$

\dot{V}_w = Equivalent water volume flow in [l/s] or [m³/h]

ρ = Density of fluid (operating condition) in [kg/m³]

\dot{V} = Volume of fluid (operating condition) in [l/s] or [m³/h]

Opening Pressures Differential pressures at zero volume flow.

RK 71*)

DN	Opening pressures [mbar]			
	Direction of flow			
	without spring	with spring		
	↑	↑	→	↓
15	2.5	10	7.5	5
20	2.5	10	7.5	5
25	2.5	10	7.5	5
32	3.5	12	8.5	5
40	4.0	13	9	5
50	4.5	14	9.5	5
65	5.0	15	10	5
80	5.5	16	10.5	5
100	6.5	18	11.5	5

RK 70*)

DN	Opening pressures [mbar]			
	Direction of flow			
	without spring	with spring		
	↑	↑	→	↓
15	0.4	5.8	5.4	5
20	0.4	5.8	5.4	5
25	0.4	5.8	5.4	5
32	0.5	6.0	5.5	5
40	0.5	6.0	5.5	5
50	0.6	6.2	5.6	5
65	0.7	6.4	5.7	5
80	0.8	6.6	5.8	5
100	0.9	6.8	5.9	5
125	2.0	9.0	7.0	5
150	2.5	10.0	7.5	5
200	2.5	10.0	7.5	5

*) RK 70, 71 are not available with special spring or without spring

RK 70, RK 71

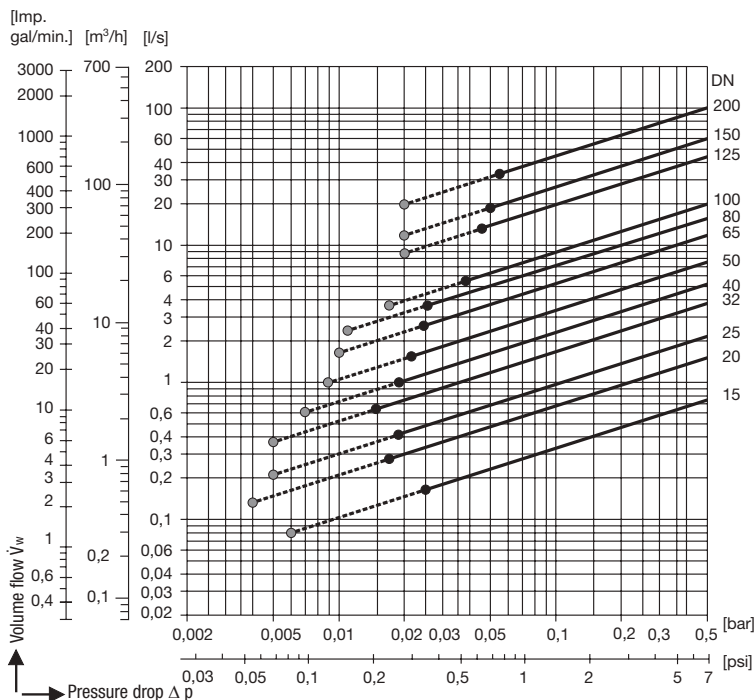

MB 14

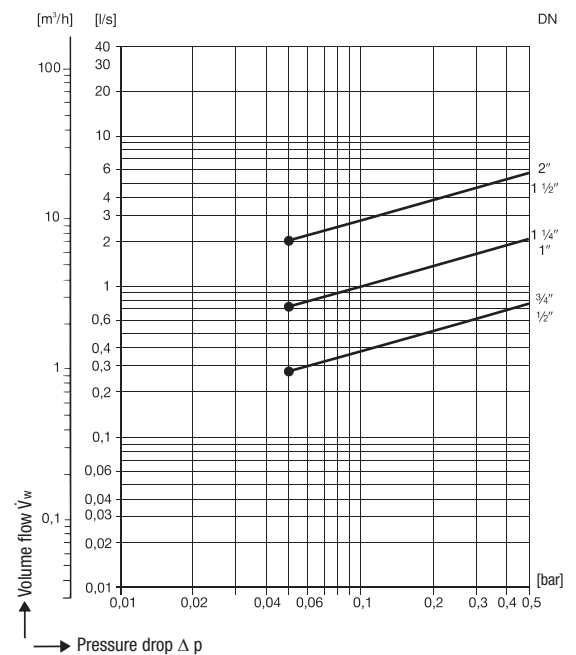

- Required minimum volume flow \dot{V}_w for equipment without spring installed in vertical pipes with upward flow (only RK 70, RK 71).
- Required minimum volume flow \dot{V}_w for equipment with standard spring and horizontal flow.

DISCO Non-Return Valves RK, PN 6 to PN 40

Short overall length according to DIN EN 558-1, table 11, series 49

(Δ DIN 3202, part 3, series K4)

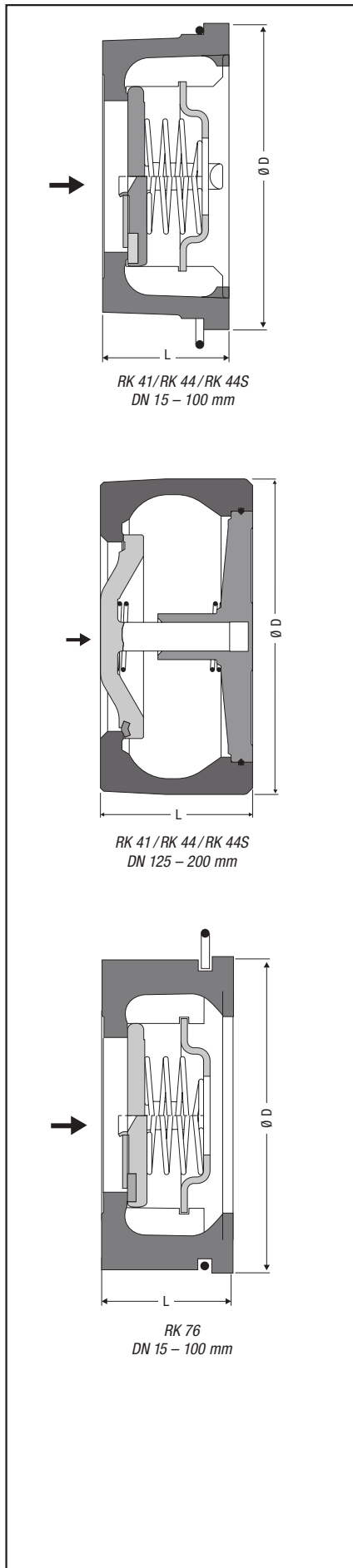

Application and Features

Type	PN	Application	Features
		for liquids, gases and vapours	
RK 41	PN 16	particularly suitable for heating and hot-water installations	4 guide ribs for low-wear operation of the valve plate
RK 44	PN 16	for fresh water applications	
RK 44S	PN 16	for sea water applications	
RK 76	PN 40 Class 300	for industrial applications	specialty designed spring cap provides centrally aligned spring support

Body Material

Type		Nominal sizes DN	EN reference	ASTM equivalent ¹⁾
RK 41	Body	15 – 100 mm	Brass (CW 617 N)	Special Brass
	Valve disk		1.4571	AISI 316 Ti
	Body	125 – 200 mm	Grey cast iron (5.1301)	A126 Class B
RK 44	Plug		1.4006	A182 F6
	Body	15 – 100 mm	Bronze (CC480 K-GS)	B584 C90500
	Valve disk		1.4571	AISI 316 Ti
RK 44S	Body	125 – 200 mm	Grey cast iron (5.1301)	A126 Class B
	Plug		Bronze (CC480 K-GS)	B584 C90500
	Body	15 – 100 mm	Bronze (CC480 K-GS)	B584 C90500
RK 44S	Valve disk		Bronze (CC483 K-GS)	B505 C90700
	Body	125 – 200 mm	Bronze (CC483 K-GC)	B505 C90700
	Plug		Bronze (CC480 K-GS)	B584 C90500
RK 76	Body	15 – 100 mm	1.4107	A217-CA15
	Valve disk		1.4571	AISI 316 Ti

¹⁾ ASTM material similar to EN material.
Observe different physical and chemical properties!

Dimensions

	DN	[mm]	15	20	25	32	40	50	65	80	100	125	150	200
				[in]	1/2	3/4	1	1 1/4	1 1/2	2	2 1/2	3	4	5
	L	[mm]	16	19	22	28	31,5	40	46	50	60	90	106	140
RK 41	D	[mm]	40	47	56	72	82	95	115	132	152	184	209	264
RK 44	D	[mm]	42	49	58	74	84	97	117	132	152	184	209	264
RK 44S	D	[mm]	42	49	58	74	84	97	117	132	152	184	209	264
RK 76	D	[mm]	45	55	65	75	85	98	118	134	154	–	–	–

Pressure/Temperature Ratings with metal-to-metal seat

Type	PN / Class	Nominal sizes DN	p / T / [bar] / [°C]		
RK 41	PN 16	15 – 100	16 / -10	16 / 150	13.5 / 200
	PN 16	125 – 200	16 / -10	12.8 / 200	9.6 / 300
RK 44	PN 16	15 – 100	16 / -200	13.5 / 200	8 / 250
	PN 16	125 – 200	16 / -10	12.8 / 200	9.6 / 300
RK 44S	PN 16	15 – 200	16 / -200	13.5 / 200 ²⁾	8 / 250 ²⁾
RK 76	PN 40	15 – 100	40.0 / -10	30.2 / 200	25.8 / 300
	Class 300		49.6 / -10	35.7 / 200	31.6 / 300

²⁾ If temperatures exceed 90 °C use valve without spring.

Designs

Type	Seat				Springs			Earthing connection
	metal-to-metal	EPDM (-40 up to 150 °C) ²⁾	FPM (-25 up to 200 °C) ²⁾	PTFE (-190 up to 250 °C) ²⁾	without spring	special spring	Nimonic spring	
RK 41	X	0	0	–	0	0	–	Use RK 86
RK 44	X	0	0	–	0	0	–	
RK 44S	X	0	0	–	0	–	–	
RK 76	X	0	0	0	0	0	0	

²⁾ Observe pressure/temp. ratings of the equipment X : standard 0 : optional – : not available

Pressure Drop Charts

The curves given in the chart are valid for water at 20 °C. To read the pressure drop for other fluids the equivalent water volume flowrate must be calculated and used in the graph \dot{V}_w .

The values indicated in the chart are applicable for spring-assisted valves with horizontal flow and to valves without spring installed in vertical pipes with upward flow.

$$\dot{V}_w = \dot{V} \cdot \sqrt{\frac{\rho}{1000}}$$

\dot{V}_w = Equivalent water volume flow in [l/s] or [m³/h]

ρ = Density of fluid (operating condition) in [kg/m³]

\dot{V} = Volume of fluid (operating condition) in [l/s] or [m³/h]

Opening Pressures Differential pressures at zero volume flow.

RK 41, RK 44, RK 76¹⁾

DN	Opening pressures [mbar]			
	Direction of flow			
	without spring	with spring		
	↑	↑	→	↓
15	2.5	10	7.5	5
20	2.5	10	7.5	5
25	2.5	10	7.5	5
32	3.5	12	8.5	5
40	4.0	13	9	5
50	4.5	14	9.5	5
65	5.0	15	10	5
80	5.5	16	10.5	5
100	6.5	18	11.5	5
125	12.5	35	22.5	10
150	14.0	38	24.0	10
200	13.5	37	23.5	10

RK 44S

DN	Opening pressures [mbar]			
	Direction of flow			
	without spring	with spring		
	↑	↑	→	↓
15	2.5	25	22.5	20
20	2.5	25	22.5	20
25	2.5	25	22.5	20
32	3.5	27	23.5	20
40	4.0	28	24.0	20
50	4.5	29	24.5	20
65	5.0	30	25.0	20
80	5.5	31	25.5	20
100	6.5	33	26.5	20
125	12.5	35	22.5	10
150	14.0	38	24.0	10
200	13.5	37	23.5	10

¹⁾ only DN 15-100

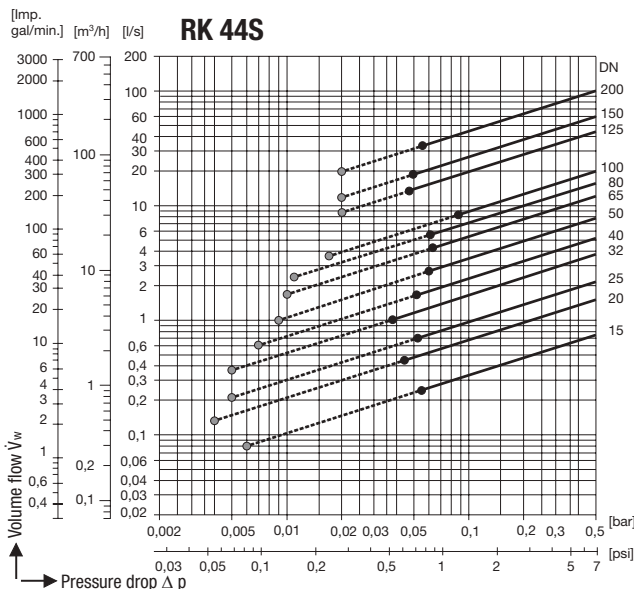
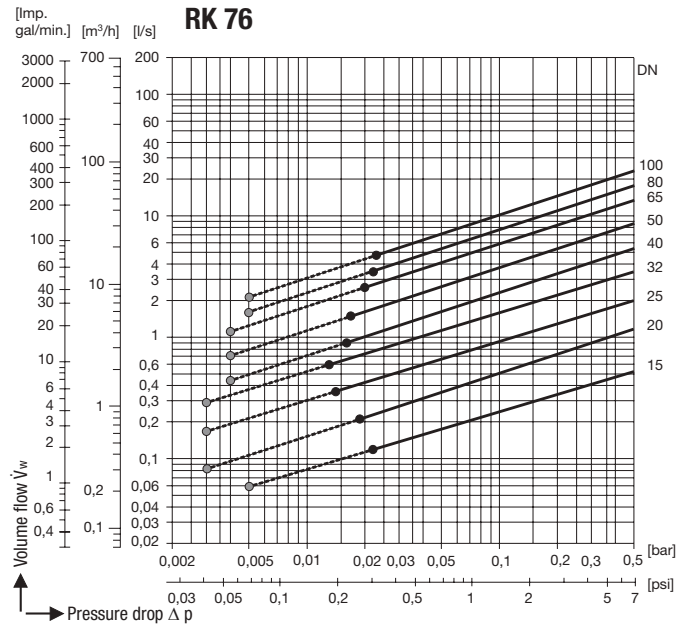
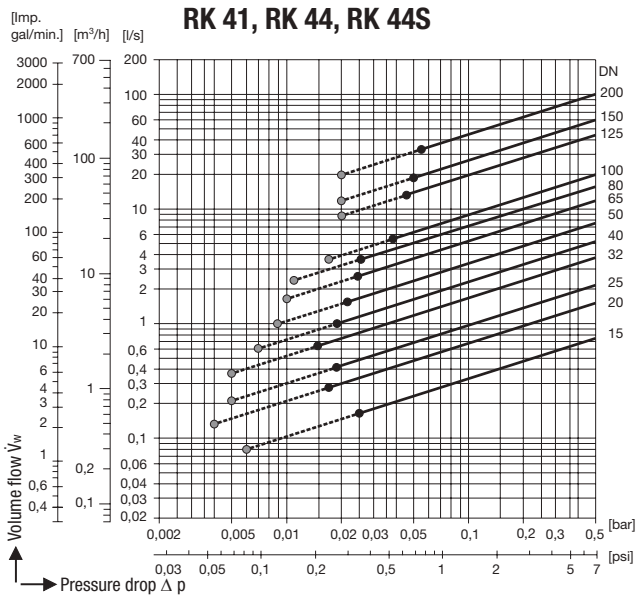

- Required minimum volume flow \dot{V}_w for equipment without spring installed in vertical pipes with upward flow.
- Required minimum volume flow \dot{V}_w for equipment with standard spring and horizontal flow.

RK 86 and RK 86 A – Our Robust All-Rounder

Application and Features

Type	PN	Application for liquids, gases and vapours	Features
RK 86	PN 40 Class 300	for industrial applications	patented fixed centering lugs for easy alignment between flanges and optimum guidance of valve disk, earthing connection as standard, broad sealing surfaces, RK 86A approved by Bureau Veritas
RK 86A		particularly suitable for low temperatures, aggressive fluids, boiler feedwater lines	

Body Material

Type		Nominal sizes DN	EN reference	ASTM equivalent 1)
RK 86	Body	15 – 100 mm	Chromium steel, 1.4317	A 743-CA6-NM
	Valve disk		1.4571	AISI 316 Ti
	Body	125 – 200 mm	GP240GH (1.0619)	A 216 WCB
	Plug		1.4006	A182 F6 A
RK 86A	Body	15 – 100 mm	1.4408	A351 CF 8M
	Valve disk		1.4571	AISI 316 Ti
	Body	125 – 200 mm	1.4408	A351 CF 8M
	Plug		1.4404	A182 F316 L

1) ASTM material similar to EN material.

Observe different physical and chemical properties!

Deimensions and Weights

	DN	[mm]	15	20	25	32	40	50	65	80	100	125	150	200
		[inch]	1/2	3/4	1	1 1/4	1 1/2	2	2 1/2	3	4	5	6	8
	L	[mm]	16	19	22	28	31.5	40	46	50	60	90	106	140
	Z min.	[mm]	44	53	64	73	83	96	110	128	151	–	–	–
	Z max.	[mm]	67	76	82	93	104	118	136	158	186	–	–	–
PN 10/16	D	[mm]	–	–	–	–	–	–	–	–	–	194	220	275
PN 25	D	[mm]	–	–	–	–	–	–	–	–	–	194	226	286
PN 40	D	[mm]	–	–	–	–	–	–	–	–	–	194	226	293
Class 125/150	D	[mm]	–	–	–	–	–	–	–	–	–	194	220	275
Class 300	D	[mm]	–	–	–	–	–	–	–	–	–	216	251	308
	Weight	[kg]	0.27	0.38	0.52	0.8	1.12	1.78	2.43	3.37	5.34	11	14	25

Pressure/Temperature Ratings with metal-to-metal seat

Type	PN / Class	Nominal sizes DN	p / T / [bar] / [°C]		
RK 86	PN 40	15 – 100	40.0 / -10	33.6 / 200	25.9 / 350 ²⁾
	Class 300		51.1 / -10	43.8 / 200	37.6 / 200
	PN 40	125 – 200	40.0 / -10	33.6 / 200	14.7 / 450
	Class 300		51.1 / -29	43.8 / 200	28.8 / 425
RK 86 A	PN 40	15 – 100	40.0 / -200	30.2 / 200	20.7 / 550 ²⁾
	Class 300		49.6 / -200	35.7 / 200	24.9 / 550 ²⁾
	PN 40	125 – 200	40.0 / -200	30.2 / 200	22.2 / 500 ²⁾
	Class 300		49.6 / -200	35.7 / 200	25.1 / 538 ²⁾

2) If the operating temperatures exceed 300 °C intercrystalline corrosion may occur. Do not subject the equipment to operating temperatures higher than 300 °C unless intercrystalline corrosion can be ruled out.

Designs

Type	Seat				Springs			Earthing connection
	metal-to-metal	EPDM (-40 up to 150 °C ³⁾)	FPM (-25 up to 200 °C ³⁾)	PTFE ³⁾⁴⁾	without spring	special spring	Nimonic spring ⁵⁾	
RK 86	X	0	0	0	0	0	0	X
RK 86A	X	0	0	0	0	0	0	X

3) Observe pressure/temp. ratings of the equipment

4) DN 15-100 -190 °C up to 250 °C; DN 125-200 -60 up to 200 °C

5) Required for temperatures above 300 °C

X : standard 0 : optional

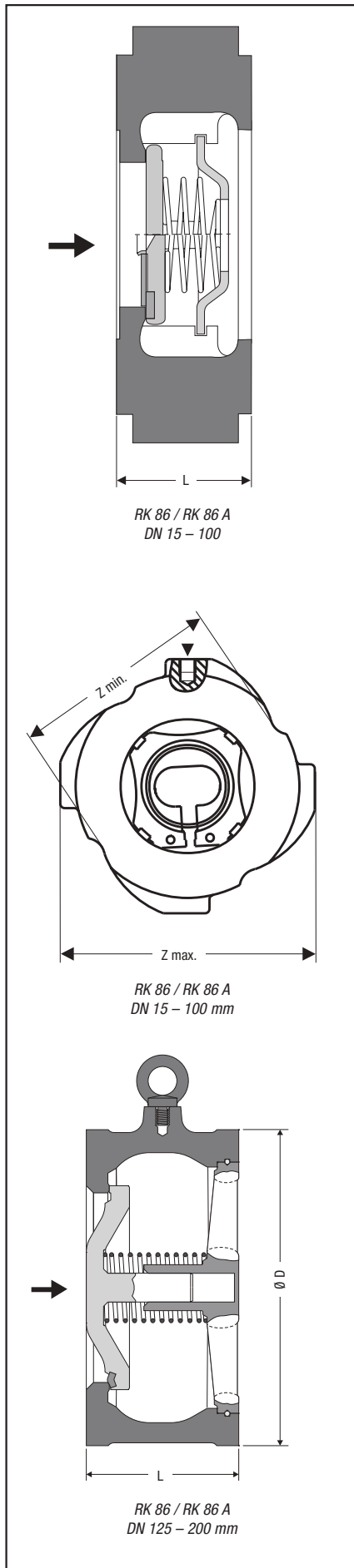

DISCO Non-Return Valves RK, PN 6 to PN 40

Short overall length according to DIN EN 558-1, table 11, series 49
 (Δ DIN 3202, part 3, series K4)



Pressure Drop Charts

The curves given in the chart are valid for water at 20 °C. To read the pressure drop for other fluids the equivalent water volume flowrate must be calculated and used in the graph \dot{V}_w .

The values indicated in the chart are applicable for spring-assisted valves with horizontal flow and to valves without spring installed in vertical pipes with upward flow.

$$\dot{V}_w = \dot{V} \cdot \sqrt{\frac{\rho}{1000}}$$

\dot{V}_w = Equivalent water volume flow in [l/s] or [m³/h]

ρ = Density of fluid (operating condition) in [kg/m³]

\dot{V} = Volume of fluid (operating condition) in [l/s] or [m³/h]

Opening Pressures

Differential pressures at zero volume flow.

RK 86, RK 86 A

DN	Opening pressures [mbar]			
	without spring ↑	Direction of flow with spring		
		↑	→	↓
15	2.5	10	7.5	5
20	2.5	10	7.5	5
25	2.5	10	7.5	5
32	3.5	12	8.5	5
40	4.0	13	9	5
50	4.5	14	9.5	5
65	5.0	15	10	5
80	5.5	16	10.5	5
100	6.5	18	11.5	5
125	12.5	35	22.5	10
150	13.5	37	23.5	10
200	14.0	38	24.0	10

RK 86, 86A

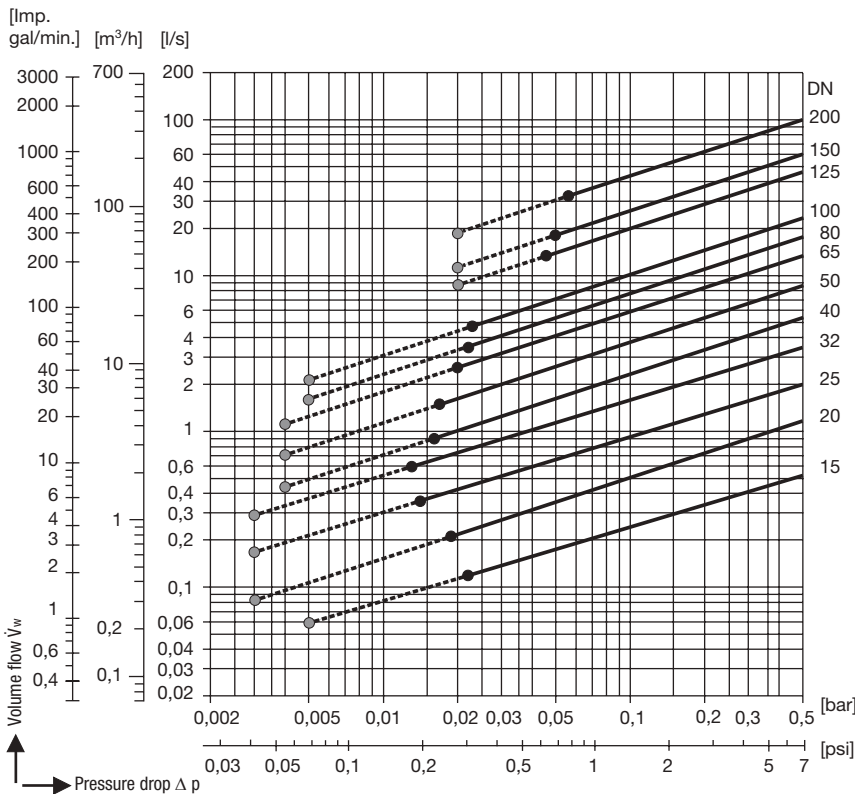

- Required minimum volume flow \dot{V}_w for equipment without spring installed in vertical pipes with upward flow.
- Required minimum volume flow \dot{V}_w for equipment with standard spring and horizontal flow.

DISCO Non-Return Valves RK, PN 40

Short overall length according to DIN EN 558-2, table 11, series 52
(Δ DIN 3202, part 3, series K5)

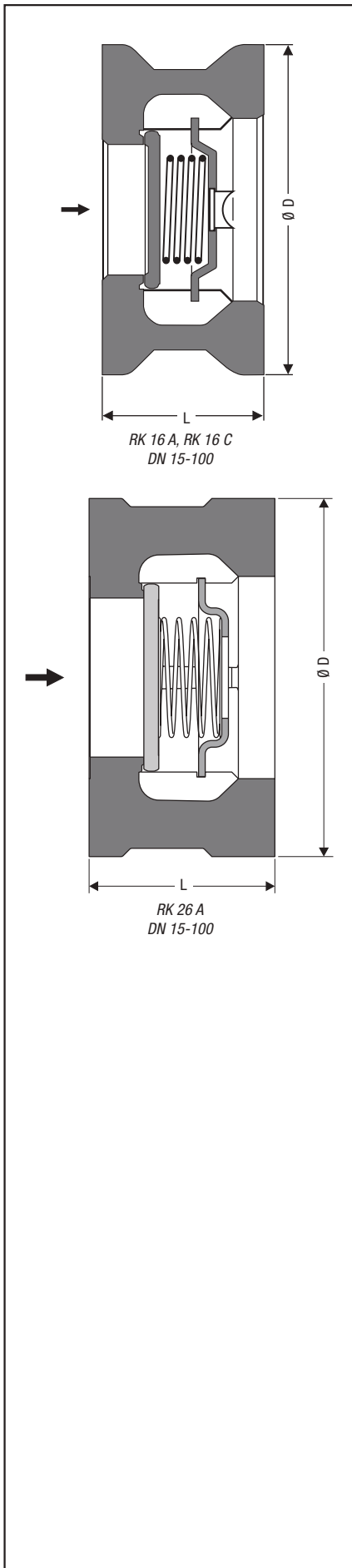

Application and Features

Type	PN	Application	Features
RK 16C	PN 40 Class 300	for liquids, gases and vapours	short overall length to DIN 558-2, series 52, high-quality forged material (RK 16A / RK 16 C) materials suitable for petrochemical industry
RK 16A		for more aggressive fluids such as hydrochloric acid	
RK 26A		particularly suitable for low temperatures, aggressive fluids, boiler feedwater lines and industrial applications	

Body Material

Type	Nominal sizes DN	EN reference	ASTM equivalent ¹⁾
RK 16A	Body	15 – 100 mm	1.4571
	Valve disk		1.4571
RK 16C	Body	15 – 100 mm	2.4610
	Valve disk		2.4610
RK 26A	Body	15 – 100 mm	1.4408
	Valve disk		1.4571

¹⁾ ASTM material similar to EN material.
Observe different physical and chemical properties!

Dimensions

	DN	[mm]	15	20	25	32	40	50	65	80	100
			[inch]	1/2	3/4	1	1 1/4	1 1/2	2	2 1/2	3
L		[mm]	25	31.5	35.5	40	45	56	63	71	80
RK 16 A	D	[mm]	52	63	72	81	93	108	128	143	163 ²⁾ 169 ³⁾
			RK 16 C	D	[mm]	52	63	72	81	93	108
RK 26 A	D	[mm]	52	63	72	81	93	108	128	143	163 ²⁾ 169 ³⁾

²⁾ PN 10/16 ³⁾ PN 25/40

Pressure/Temperature Ratings with metal-to-metal seat

Type	PN / Class	Nominal sizes DN	p / T / [bar] / [°C]		
RK 16 A	PN 40	15 – 100	40.0 / -200	35.8 / 200	23.3 / 550 ⁴⁾
	Class 300		50.4 / -200	38.4 / 200	24.9 / 550 ⁴⁾
RK 16 C	PN 40	15 – 100	40.0 / -200	36.00 / 200	32.0 / 400 ⁴⁾
	Class 300		51.7 / -200	48.3 / 200	36.5 / 400 ⁴⁾
RK 26 A	PN 40	15 – 100	40.0 / -200	30.2 / 200	20.7 / 550 ⁴⁾
	Class 300		49.6 / -200	35.7 / 200	24.9 / 550 ⁴⁾

⁴⁾ If the operating temperatures exceed 300 °C intercrystalline corrosion may occur. Do not subject the equipment to operating temperatures higher than 300 °C unless intercrystalline corrosion can be ruled out.

Designs

Type	Seat				Spring			Earthing connection
	meta-to-metal	EPDM (-40 up to 150 °C) ⁵⁾	FPM (-25 up to 200 °C) ⁵⁾	PTFE (-190 up to 250 °C) ⁵⁾	without spring	special spring	Nimonic spring ⁶⁾	
RK 16 A	X	0	0	0	0	0	0	0
RK 16 C	X	-	-	-	0	-	-	0
RK 26 A	X	0	0	0	0	0	0	0

⁵⁾ Observe pressure/temp. ratings of the equipment

⁶⁾ Required for temperatures above 300 °C.

X : standard

0 : optional

- : not available

Pressure Drop Charts

The curves given in the chart are valid for water at 20 °C. To read the pressure drop for other fluids the equivalent water volume flowrate must be calculated and used in the graph \dot{V}_w .

The values indicated in the chart are applicable for spring-assisted valves with horizontal flow and to valves without spring installed in vertical pipes with upward flow.

$$\dot{V}_w = \dot{V} \cdot \sqrt{\frac{\rho}{1000}}$$

\dot{V}_w = Equivalent water volume flow in [l/s] or [m³/h]

ρ = Density of fluid (operating condition) in [kg/m³]

\dot{V} = Volume of fluid (operating condition) in [l/s] or [m³/h]

Opening Pressures

Differential pressures at zero volume flow.

RK 16 A, RK 26 A

DN	Opening pressures [mbar]			
	without spring	Direction of flow with spring		
		↑	↑	→
15	2.5	10	7.5	5
20	2.5	10	7.5	5
25	2.5	10	7.5	5
32	3.5	12	8.5	5
40	4.0	13	9	5
50	4.5	14	9.5	5
65	5.0	15	10	5
80	5.5	16	10.5	5
100	6.5	18	11.5	5

Opening Pressures

Differential pressures at zero volume flow.

RK 16 C

DN	Opening pressures [mbar]			
	without spring	Direction of flow with spring		
		↑	↑	→
15	2.5	25	22.5	20
20	2.5	25	22.5	20
25	2.5	25	22.5	20
32	3.5	27	23.5	20
40	4.0	28	24.0	20
50	4.5	29	24.5	20
65	5.0	30	25.0	20
80	5.5	31	25.5	20
100	6.5	33	26.5	20

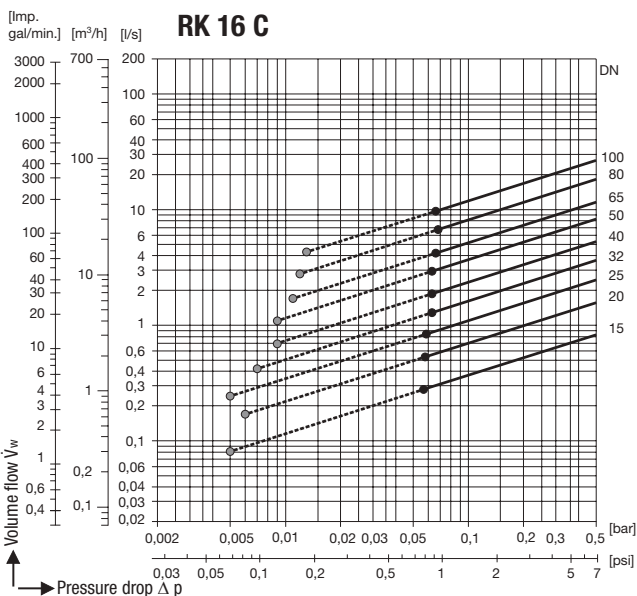
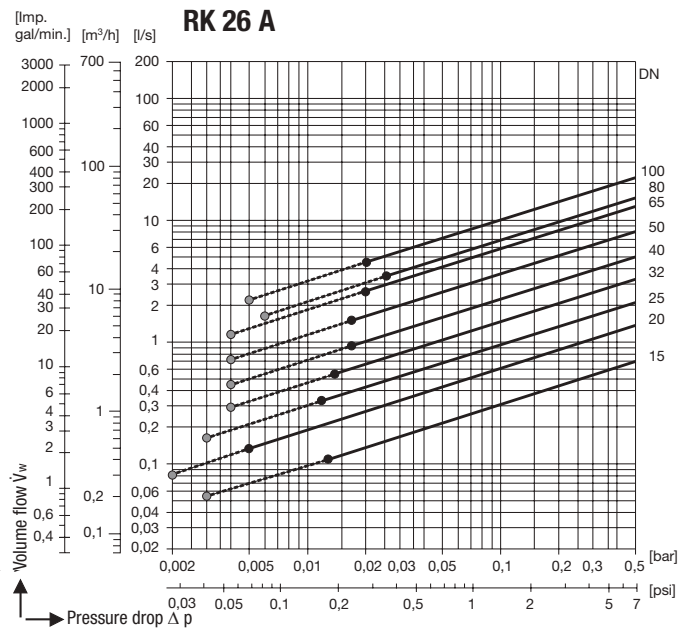
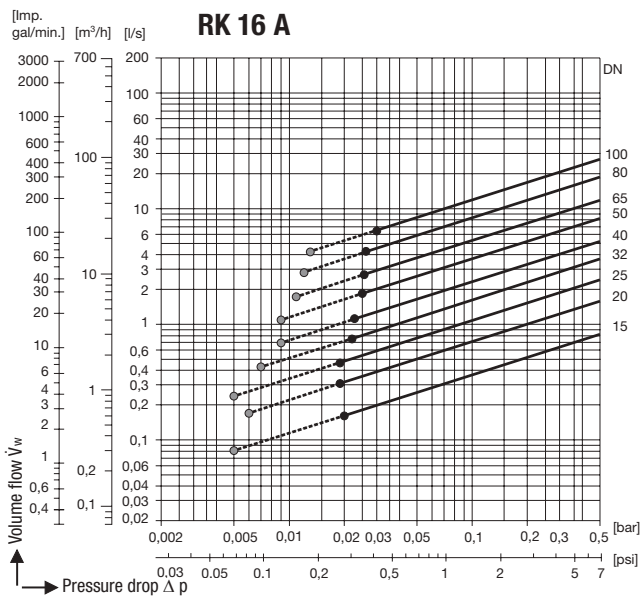

- Required minimum volume flow \dot{V}_w for equipment without spring installed in vertical pipes with upward flow.
- Required minimum volume flow \dot{V}_w for equipment with standard spring and horizontal flow.

DISCO Non-Return Valves RK, PN 63 to PN 160

Short overall length according to DIN EN 558-2, table 11, series 52
(Δ DIN 3202, part 3, series K5)

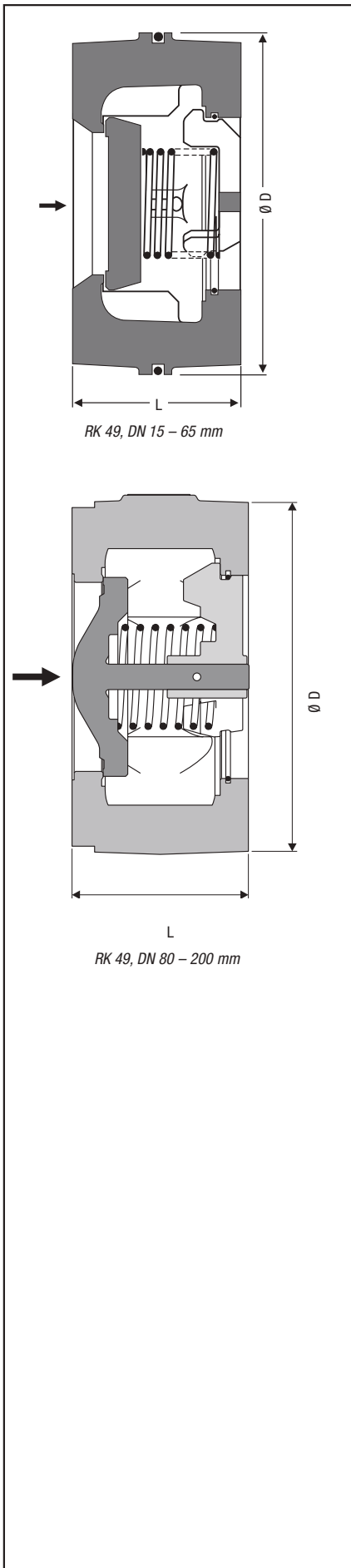

RK 49, DN 15 – 65 mm

RK 49, DN 80 – 200 mm

Application and Features

Type	PN	Application	Features
		for liquids, gases and vapours	
RK 49	PN 63 – 160 Class 400 – 900	suitable for high pressures and temperatures	double centric spring guidance (DN 15-65), centric cone & spring guide unaffected by dirt (DN 80, 100), installation in any position, spring made of Nimonic

Body Material

Type	Nominal sizes DN	EN reference	ASTM equivalent 1)
RK 49	Body	15 – 65 mm	1.4581
	Valve disk		1.4986
RK 49	Body	80 – 100 mm	1.7357
	Plug		1.4923

1) ASTM material similar to EN material.
Observe different physical and chemical properties!

Dimensions

RK 49	DN	[mm]	15	20	25	32	40	50	65	80	100
		[in]	1/2	3/4	1	1 1/4	1 1/2	2	2 1/2	3	4
	L	[mm]	25	31.5	35.5	40	45	56	63	71	80
	D	[mm]	54	63	74	84	95	110	130	147	173
	Weight	[kg]	0.43	0.7	1.0	1.4	2	3	4.7	7.1	12.1

Pressure/Temperature Ratings with metal-to-metal seat

Type	PN / Class	Nominal sizes DN	p / T / [bar] / [°C]		
RK 49	PN 63 – 160	15 – 65	160.0 / -10	143.4 / 200	93.2 / 550 ²⁾
	Class 400 – 900		151.2 / -10	115.2 / 200	74.8 / 550 ²⁾
	PN 63 – 160	80 – 100	160.0 / -10	160.0 / 300	47.0 / 550 ²⁾
	Class 400 – 900		155.1 / -10	145.9 / 200	37.7 / 550 ²⁾

2) If the operating temperatures exceed 300 °C intercrystalline corrosion may occur. Do not subject the equipment to operating temperatures higher than 300 °C unless intercrystalline corrosion can be ruled out.

Seat tightness acc. to DIN EN 12266-1, leakrate C

For additional information on chemical resistance see GESTRA Information "Chemical Resistance"

Machining of seating faces acc. to EN 1092-1, form B2,

ASME B 16.5 RF (optional: ring joint facing)

Designs

Type	Seat				Springs			Earthing connection
	metal-to-metal	EPDM	FPM	PTFE	without spring	special spring	Nimonic spring 3)	
RK 49	X	–	–	–	0	–	X	0

3) Required for temperatures above 300 °C.

X : standard
0 : optional
– : not available

DISCO Non-Return Valves RK, PN 63 to PN 160

Short overall length according to DIN EN 558-2, table 11, series 52
 (≙ DIN 3202, part 3, series K5)



Pressure Drop Charts

The curves given in the chart are valid for water at 20 °C. To read the pressure drop for other fluids the equivalent water volume flowrate must be calculated and used in the graph \dot{V}_w .

The values indicated in the chart are applicable for spring-assisted valves with horizontal flow and to valves without spring installed in vertical pipes with upward flow.

$$\dot{V}_w = \dot{V} \cdot \sqrt{\frac{\rho}{1000}}$$

\dot{V}_w = Equivalent water volume flow in [l/s] or [m³/h]

ρ = Density of fluid (operating condition) in [kg/m³]

\dot{V} = Volume of fluid (operating condition) in [l/s] or [m³/h]

Opening Pressures

Differential pressures at zero volume flow.

RK 49

DN	Opening pressures [mbar]			
	without spring ↑	Direction of flow with spring		
		↑	→	↓
15	16.5	73	56.5	40
20	17.5	74	57.0	40
25	18.0	76	58.0	40
32	18.0	76	58.0	40
40	19.5	79	59.5	40
50	22.0	84	62.0	40
65	23.0	87	63.0	40
80	17.5	75	57.5	40
100	20.0	80	60.0	40

RK 49

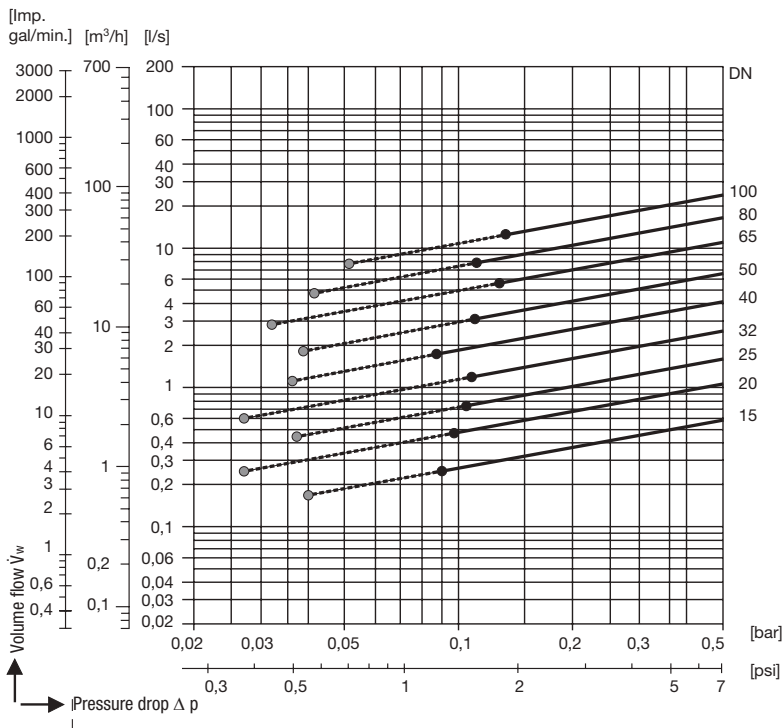

- Required minimum volume flow \dot{V}_w for equipment without spring installed in vertical pipes with upward flow.
- Required minimum volume flow \dot{V}_w for equipment with standard spring and horizontal flow.

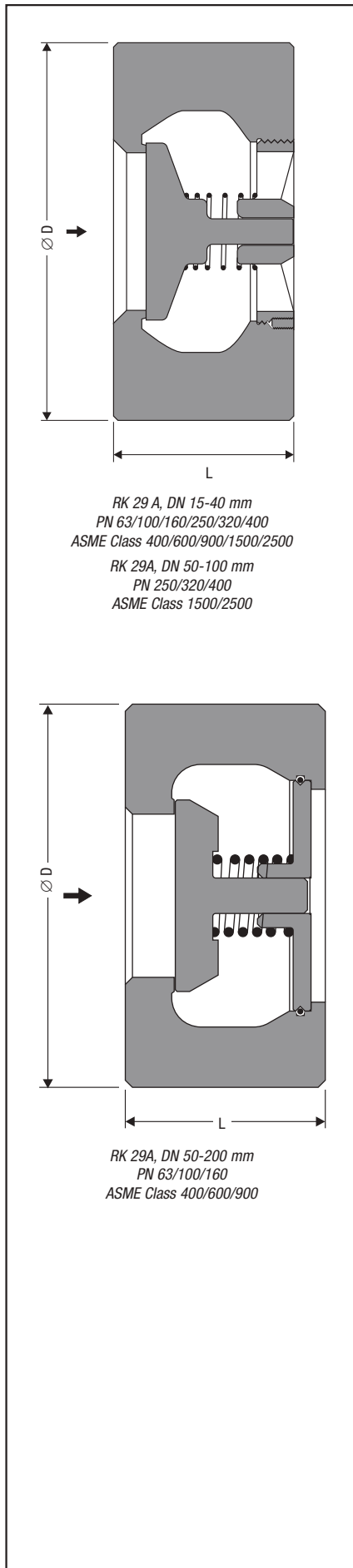

Application and Features

Type	PN	Application	Features
RK 29 A	PN 63 – 400 Class 400 – 2500	for liquids, gases and vapours for high pressure ratings and special tasks	for pressure ratings up to ON 400 / Class 2500, centric cone guide unaffected by dirt, adjusted diameter ensures optimum body centering, material suitable for petrochemical applications

Materials

Type	Nominal sizes DN	EN reference	ASTM equivalent ¹⁾
RK 29A Body	15 – 200 mm	1.4571	AISI 316 Ti
Plug		1.4571	AISI 316 Ti

¹⁾ ASTM material similar to EN material. Observe different physical and chemical properties!

Dimensions

DN	[mm]	15	25	40	50	80	100	150	200
	[inch]	1/2	1	1 1/2	2	3	4	6	8
L	[mm]	35	40	56	56	71	80	125	160
PN 63	D	63	84	105	115	149	176	250	312
PN 100	D	63	84	105	121	156	183	260	327
PN 160	D	63	84	105	121	156	183	260	327
PN 250	D	74	84	111	126	173	205	–	–
PN 320	D	74	95	121	136	193	232	–	–
PN 400	D	80	106	138	153	210	259	–	–
Class 400	D	54	73	95	111	149	176	247.5	304.5
Class 600	D	54	73	95	111	149	193.5	266.5	320.5
Class 900	D	63	79	98	142.5	168	205	288.5	358.5
Class 1500	D	63	79	98	142.5	173	209.5	–	–
Class 2500	D	69.5	84	117	146	196.5	234.5	–	–

Pressure/Temperature Ratings

Type	PN / Class	DN	p / T / [bar] / [°C]		
RK 29 A	PN 63	15 – 200	63 / –200	56.4 / 200	36.7 / 550 ²⁾
	PN 100	15 – 200	100 / –200	89.6 / 200	58.2 / 550 ²⁾
	PN 160	15 – 200	160 / –200	143.4 / 200	93.2 / 550 ²⁾
	PN 250	15 – 100	250 / –200	224.1 / 200	145.6 / 550 ²⁾
	PN 320	15 – 100	320 / –200	286.8 / 200	186.4 / 550 ²⁾
	PN 400	15 – 100	400 / –200	358.5 / 200	232.9 / 550 ²⁾
	Class 400	15 – 200	67.0 / –218	51.2 / 200	33.2 / 550 ²⁾
	Class 600	15 – 200	100.8 / –218	76.8 / 200	49.9 / 550 ²⁾
	Class 900	15 – 200	151.2 / –218	115.2 / 200	74.8 / 550 ²⁾
	Class 1500	15 – 100	252.0 / –218	192 / 200	124.7 / 550 ²⁾
Class 2500	15 – 100	420.0 / –218	320 / 200	207.9 / 550 ²⁾	

²⁾ If the operating temperatures exceed 300 °C intercrystalline corrosion may occur. Do not subject the equipment to operating temperatures higher than 300 °C unless intercrystalline corrosion can be ruled out.

Tightness of seat in accordance with DIN EN 12266-1, leakage rate D.

For information on chemical resistance go to www.gestra.de, click on “Service & Support” and then on “Chemical Resistance”

Sealing surfaces machined according to EN 1092-1, form B2, ASME B 16.5 RF smooth finish (63-125 µin). Other designs available on request.

Designs

Type	Seat				Springs without spring	special spring	Nimonic spring ⁴⁾	Earthing connection
	metal-to-metal	EPDM (-40 up to 150 °C) ³⁾	FPM (-25 up to 200 °C) ³⁾	PTFE (-190 up to 250 °C) ³⁾				
RK 29A	X	–	–	–	0	–	X	0

³⁾ Observe pressure/temp. ratings of the equipment

⁴⁾ Required for temperatures above 300 °C.

X : standard

0 : optional

– : not available

Pressure Drop Charts

The curves given in the chart are valid for water at 20 °C. To read the pressure drop for other fluids the equivalent water volume flowrate must be calculated and used in the graph \dot{V}_w .

The values indicated in the chart are applicable to spring-assisted valves with horizontal flow.

$$\dot{V}_w = \dot{V} \cdot \sqrt{\frac{\rho}{1000}}$$

\dot{V}_w = Equivalent water volume flow in [l/s] or [m³/h]

ρ = Density of fluid (operating condition) in [kg/m³]

\dot{V} = Volume of fluid (operating condition) in [l/s] or [m³/h]

Opening Pressures

Differential pressures at zero volume flow.

RK 29 A

DN	Opening pressures [mbar]							
	without spring				with spring			
	↑		↑		→		↓	
	- PN 160 - CI 900	- PN 400 - CI 2500	- PN 160 - CI 900	- PN 400 - CI 2500	- PN 160 - CI 900	- PN 400 - CI 2500	- PN 160 - CL 900	- PN 400 - CI 2500
15	6	6	22	22	16	16	10	10
25	8	8	26	26	18	18	10	10
40	10	10	30	30	20	20	10	10
50	10	10	30	30	20	20	10	10
80	11	13	32	36	21	23	10	10
100	12	24	34	58	22	34	10	10
150	18	-	46	-	28	-	10	-
200	21	-	52	-	31	-	10	-

RK 29A

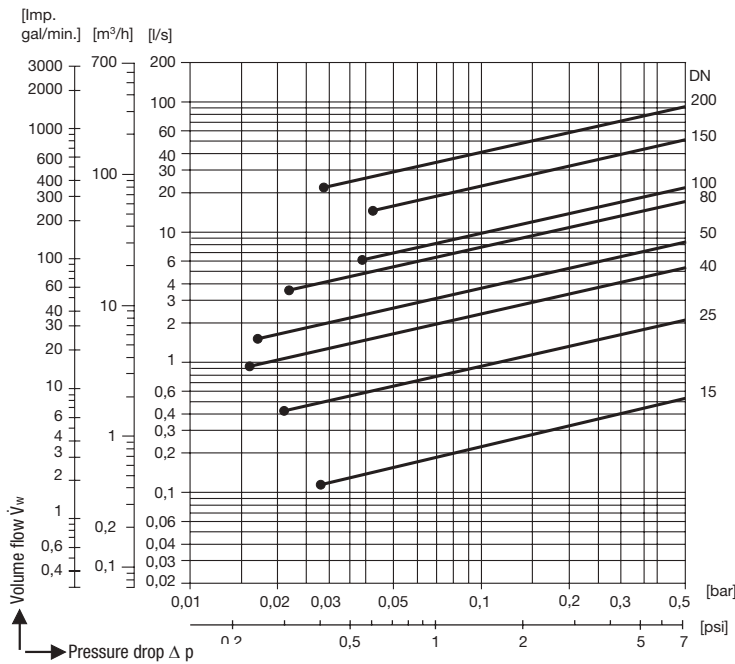

■ Required minimum volume flow \dot{V}_w for equipment with standard spring and horizontal flow.

DISCOCHECK® Dual-Plate Check Valves BB

Short overall length according to DIN EN 558-1, table 11, series 16
(≙ DIN 3202, part 3, series K3)

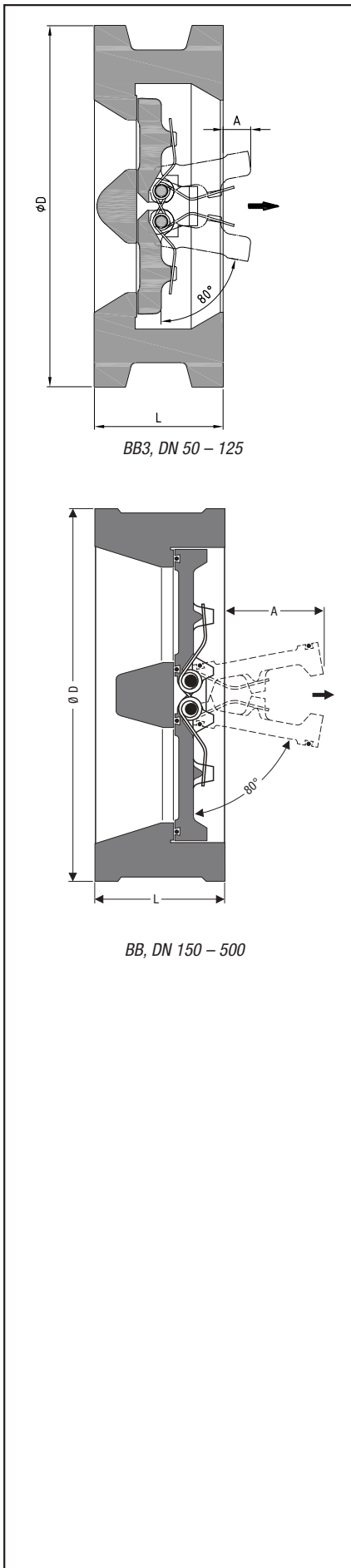

Application and Features

Type	PN	Application	Features
BB EN BB ASME	PN 10 – 40 Class 150 – 300	for liquids, gases and vapours suitable for heating, air-conditioning, water supply and cooling installations, for applications where minimum pressure loss is required, for frequency-controlled pumps	top quality, minimum pressure loss, for horizontal and vertical installations, stable operation when partly open (horizontal), downward flow (special spring), 2 hinge pins, 4 springs to close, disc plates with individually suspended stop lugs, swing stop for stable opening position, angle when fully open: 80°, coated or with closing damper

Materials

Design	Part designation	Nominal size DN	EN reference	ASTM equivalent ¹⁾
Grey cast iron (BB ... G)	Body	150 – 500	5.1301	A 126 Class A
	Dual plate	150 – 500	5.3106	A 536 60-40-18
Carbon steel (BB ... C)	Body	50 – 500	1.0619	A 216 WCB
	Dual plate	50 – 80	1.4404	A 182 F316L
	Dual plate	100 – 500	1.0619	A 216 WCB
Stainless steel (BB ... A)	Body	50 – 500	1.4408	A 351 CF8M
	Dual plate	50 – 80	1.4404	A 182 F316L
	Dual plate	100 – 500	1.4408	A 351 CF8M

¹⁾ Physical and chemical properties comply with EN grade.

Pressure/Temperature Ratings with metal-to-metal seat

EN series	Type	PN	Max. service pressure [bar] at temperature [°C] ²⁾			
			20	300	450	550
Grey cast iron down to –10 °C at nominal pressure	BB 11G / 21G	PN 6	6	3.6	–	–
	12G / 22G	PN 10	10	6.0	–	–
	14G / 24G	PN 16	16	9.6	–	–
Carbon steel down to –10 °C at nominal pressure	BB 12C/22C/32C	PN 10	10	7.0	3.7	–
	14C/24C/34C	PN 16	16	11.1	5.9	–
	15C/25C/35C	PN 25	25	17.4	9.2	–
	16C/26C/36C	PN 40	40	27.8	14.7	–
Stainless steel ³⁾ down to –200 °C at nominal pressure	BB 12A/22A/32A	PN 10	10	6.4	5.7	5.2
	14A/24A/34A	PN 16	16	10.3	9.1	8.3
	15A/25A/35A	PN 25	25	16.1	14.1	12.9
	16A/26A/36A	PN 40	40	25.8	22.6	20.7

ASME series	Type	Class	Max. service pressure [bar] at temperature [°C] ²⁾				
			20	300	425	450	538
Carbon steel down to –29 °C at nominal pressure	DN 50 - DN 500						
	BB 15C/BB 25C/BB 35C	150	19.6	10.2	5.5	–	–
	BB 16C/BB 26C/BB 36C	300	51.1	39.8	28.8	–	–
Stainless steel ³⁾ down to –200 °C at nominal pressure	DN 50 - DN 500						
	BB 15A/BB 35A	150	19.0	10.2	5.5	4.6	1.4
	BB 16A/BB 36A	300	49.6	31.6	29.1	28.8	25.2

²⁾ For temperatures above +300 °C special springs of Inconel X 750 are required.

³⁾ If the operating temperatures exceed 300 °C intercrystalline corrosion may occur. Do not subject the equipment to operating temperatures higher than 300 °C unless intercrystalline corrosion can be ruled out.

Seat gasket	Temperature [°C]	Seat gasket	Temperature [°C]
EPDM	–40 up to +150	FPM (FKM)	–25 up to +200
NBR	–30 up to +110	PTFE / FPM	–25 up to +200 (from DN 150)

DISCOCHECK® Dual-Plate Check Valves BB

Short overall length according to DIN EN 558-1, table 11, series 16
 (Δ DIN 3202, part 3, series K3)



Minimum volume flow [m³/h]

Flow direction	↑	→		→	
Spring type	without spring	with spring 7 WA		with spring 2 WA	
DN	fully open	stable partial opening*)	fully open	stable partial opening*)	fully open
50	12	4	9	3	7
65	18	5	17	3,5	12
80	30	6	25	4	18
100	65	7	58	5	38
125	105	10	70	6	40
150	130	12	70	9	44
200	320	30	230	20	170
250	480	50	300	30	200
300	750	78	500	42	360
350	950	140	600	80	380
400	1300	200	800	110	460
450	1800	250	900	130	550
500	2300	280	1200	160	650

Values based on water at 20 °C

*) Provide stabilizing leg (at least 5 times DN upstream and twice DN downstream of the equipment).

If the flowrate is below the minimum volume flow (instable area) increased wear and noise are to be expected.

Opening Pressures

Differential pressures at zero volume flow.

Flow direction	↑	→	↓	
Spring type	without spring	7 WA	7 WA ¹⁾	5 VO
DN	Opening pressures [mbar]			
50	6	13	7	5
65	6	13	7	5
80	7	14	7	5
100	7	14	7	5
125	10	17	7	5
150	11	18	7	5
200	12	19	7	5
250	14	21	7	5
300	15	22	7	5
350	17	24	7	5
400	19	26	7	5
450	22	29	7	5
500	23	30	7	5

¹⁾ 2WA spring, opening pressure 2 mbar

Pressure Drop Chart

The curves given in the chart are valid for water at 20 °C. To read the pressure drop for other fluids the equivalent water volume flowrate must be calculated and used in the graph \dot{V}_w .

The values indicated in the chart are applicable to valves equipped with standard spring 7 mbar and horizontal flow as well as valves with special spring 2 mbar and horizontal flow.

$$\dot{V}_w = \dot{V} \cdot \sqrt{\frac{\rho}{1000}}$$

\dot{V}_w = Equivalent water volume flow in [l/s] or [m³/h]

ρ = Density of fluid (operating condition) in [kg/m³]

\dot{V} = Volume of fluid (operating condition) in [l/s] or [m³/h]

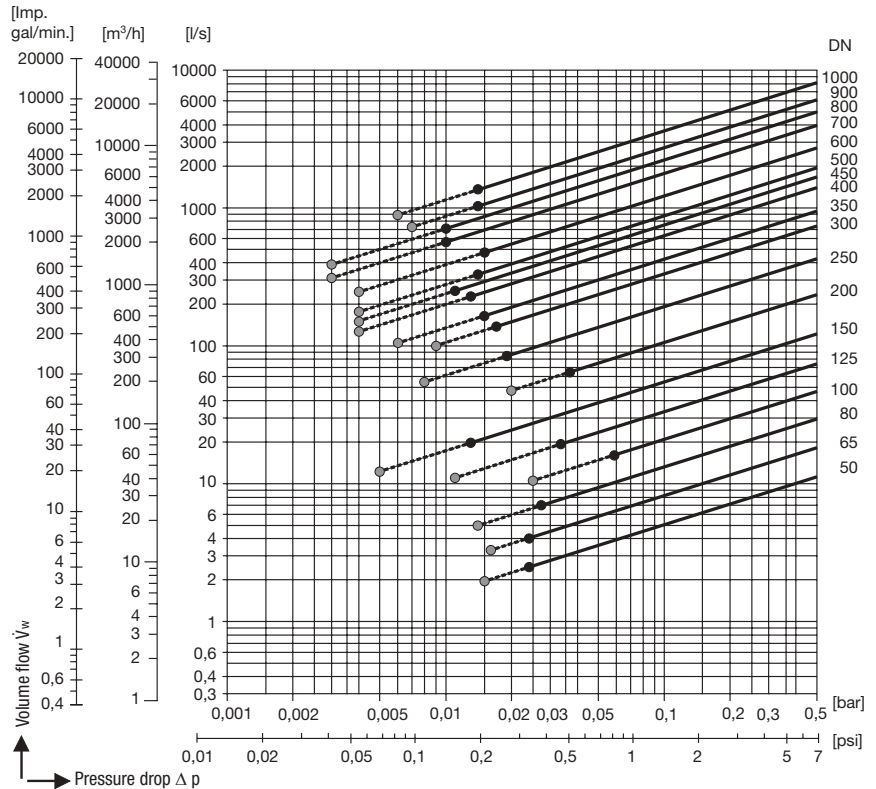

- Required minimum volume flow \dot{V}_w for valves with special spring 2 WA and horizontal flow.
- Required minimum volume flow \dot{V}_w for valves with standard spring 7 WA and horizontal flow.

DISCOCHECK® Dual-Plate Check Valves BB

Short overall length according to DIN EN 558-1, table 11, series 16
(≙ DIN 3202, part 3, series K3)



Dimensions and Weights EN Series

DN	PN	Dimensions [mm]			Weight ¹⁾ [kg]
		D	L	A	
50 ²⁾	10	109	43	8	2.0
	16	109			2.0
	25	109			2.0
	40	109			2.0
65 ²⁾	10	129	46	11	3.0
	16	129			3.0
	25	129			3.0
	40	129			3.0
80 ²⁾	10	144	64	12	4.5
	16	144			4.5
	25	144			4.5
	40	144			4.5
100	10	164	64	19	6.0
	16	164			6.0
	25	171			6.5
	40	171			6.5
125	10	194	70	28	9.0
	16	194			9.0
	25	196			9.5
	40	196			9.5
150	6	209	76	40	12
	10	220			13.5
	16	220			13.5
	25	226			14
	40	226			14
200	6	264	89	64	18.5
	10	275			20
	16	275			20
	25	286			22
	40	293			23

¹⁾ Weights rated for cast steel grade GP 240 GH (GS-C 25).

²⁾ DN 50, 65 and 80 only available as BB... "A" (stainless steel).

Other sizes on request

Dimensions and Weights ASME Series

DN	Class	Dimensions [mm]			Weight [kg]
		D	L	A	
2/50	150	105	60 ^{*)}	0	2.5
	300	111	60 ^{*)}	0	3.0
2,5/65	150	124	67 ^{*)}	0	3.5
	300	130	67 ^{*)}	0	4.0
3/80	150	137	73 ^{*)}	5	4.5
	300	149	73 ^{*)}	5	5.0
4/100	150	175	73 ^{*)}	10	7.5
	300	181	73 ^{*)}	10	8.0
5/125	150	197	86 ¹⁾	12	11.0
	300	216	86 ¹⁾	12	13.0
6/150	150	222	76	36	14.0
	300	251	76	36	14.0
8/200	150	279	89	70	22.0
	300	308	89	70	23.0
10/250	150	340	114	88	38.0
	300	362	114	88	41.0
12/300	150	410	114	109	51.0
	300	422	114	109	55.0
14/350	150	451	127	113	73.0
	300	486	127	113	79.0
16/400	150	514	140	140	96.0
	300	540	140	140	107.0
18/450	150	549	152	163	138.0
	300	597	152	163	152.0
20/500	150	606	152	181	170.0
	300	654	152	181	223.0

¹⁾ Overall length not standardized

^{*)} DN 50 – DN 100 overall length to API 594

BB with lining from DN 150

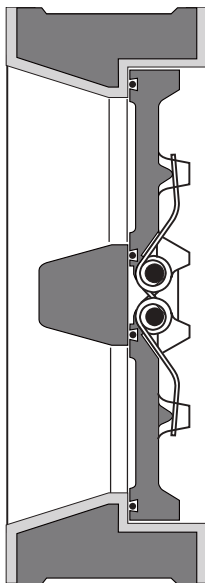

Hard-rubber lining

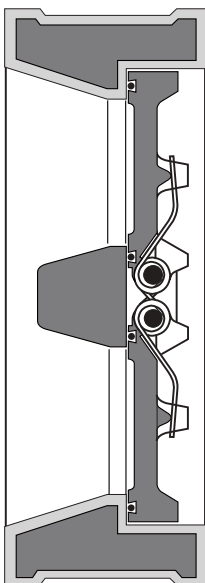

Plastic lining

Dual plates, hinge pins and springs are not lined.
Dual plates standard with O-rings of EPDM.

BB with Lining

Application and Features

Type	PN	Application	Features
		for liquids, gases and vapours	
BB..GS		for salty fluids such as sea water	hard rubber coating for protection against abrasive media, thickness of coating 3 - 5 mm
BB..GK	PN 10 – 16	for salty fluids such as sea water and for drinking water installations	plastic coating incl. inside and outside lining of the valve body, coating meets requirements of plastics for drinking water and is approved by DVGW (German Technical Association for Gas and Water), more features specified under BB EN / ASME

Materials

Made from grey cast iron (BB.. GS, GK)

Component	EN number	ASME ¹⁾
Body	EN-JL 1040	A126B
Dual plates for equipment with lining and internals made from austenitic steel	1.4408	A351CF8M
Support and hinge pin	1.4571	A316Ti
Springs	1.4571	A316Ti
Dual plates for equipment with lining and internals made from bronze	CC332G	²⁾
Support and hinge pin	CW453K	C51900
Springs	CW452K	C52100

¹⁾ Equipment made from grey cast iron that complies with ASME specification is not available. The equivalent material specifications are stated for guidance only. Physical and chemical properties of the materials can therefore differ from the materials in accordance with ASME specification. For more details please contact the manufacturer.

²⁾ There is no ASME equivalent for the EN material.

Lining materials for BB.. GS

Hard rubber based on isoprene rubber (IR), shore D hardness 75±5, max. thickness of layer 3-5 mm.

Lining materials for BB.. GK

Vestosint is a polyamide 12 based powder for fluidized bed sintering, shore D hardness 75±5, max. thickness of layer ≥ 0.4 mm.

Rilsan is a polyamide 11 based powder for fluidized bed sintering and a coating powder extracted from a purely plant based source, which means that a natural, environmentally friendly and renewable raw material is used.

Approvals/certificates acc. to KTW (recommendations for plastics in contact with drinking water) and DVGW (= German Technical Association for Gas and Water)

Shore D hardness 75±5, min. thickness of layer ≥ 0.4 mm

Other linings available on request.

Temperature Limits

Hard rubber lining –10°C up to 90°C

Plastic lining –10°C up to 90°C

DISCOCHECK® Dual-Plate Check Valves BB

Short overall length according to DIN EN 558-1, table 11, series 16
(≙ DIN 3202, part 3, series K3)

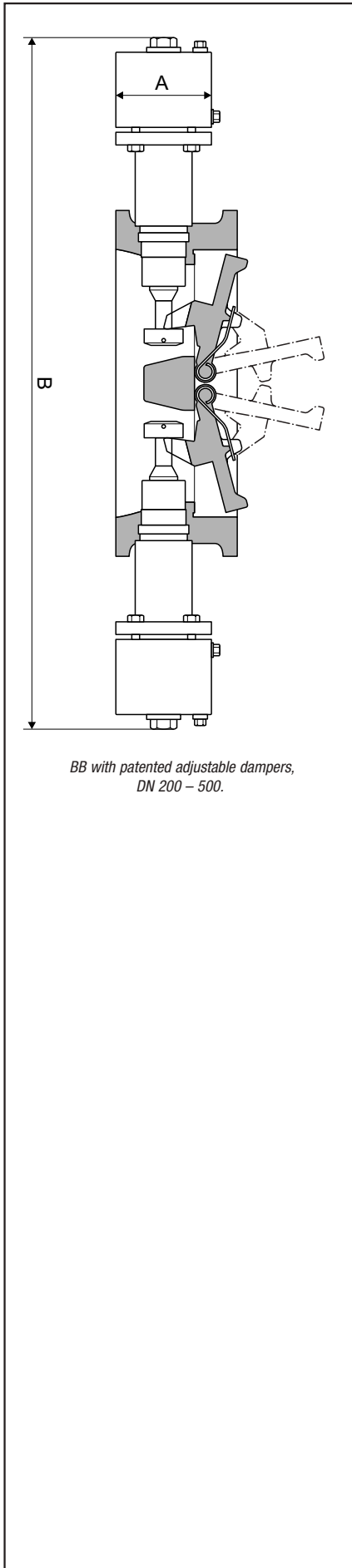

BB with patented adjustable dampers,
DN 200 – 500.

BB with Dampers *)

Application and Features

Type	PN	Application for liquids	Features
BB EN	PN 10 – 40	e. g. for water supply and cooling installations, if waterhammer occurs in pipes conducting liquids, for preventing damage to the plant. To evaluate potential waterhammer problems please aks for our questionnaire.	slows down the closing process of the non-return valve, reduces the speed of return flow, damper does not change the overall length of the equipment, dampening cylindre made of rustproof material
BB ASME	Class 150 – 300		

Materials

Component	EN	ASME ¹⁾
Hinge pin	1.4122	–
Guide bush, flange, cover	1.4104	AISI430F
Gasket	1.4571	AISI316Ti
O ring, inside	NBR	–

¹⁾ The equivalent material specifications are stated for guidance only. Physical and chemical properties of the materials can therefore differ from the materials in accordance with ASME specification.

*) Not suitable for BB with coating

Dimensions and Weights of Equipment with Closing Dampers

DN	200	250	300	350	400	500
NPS	8	10	12	14	16	20
A [mm]	90				120	
B [mm] ¹⁾	600	665	715	755	900	995
Weight [kg] ¹⁾	33	48	60	82	121	197

¹⁾ The indicated values are based on equipment PN 16. Specifications for other equipment types available on request.

Pressure/Temperature Ratings

Size DN	[mm]	200	250	300	350	400	500
	[inch]	8	10	12	14	16	20
Max. service pressure	[bar]	16	16	13	9	13	9
Max. service temperature	[°C]	110					
Max. admissible pressure at line leading to the valve (pump switched off)	[bar]	0.5					

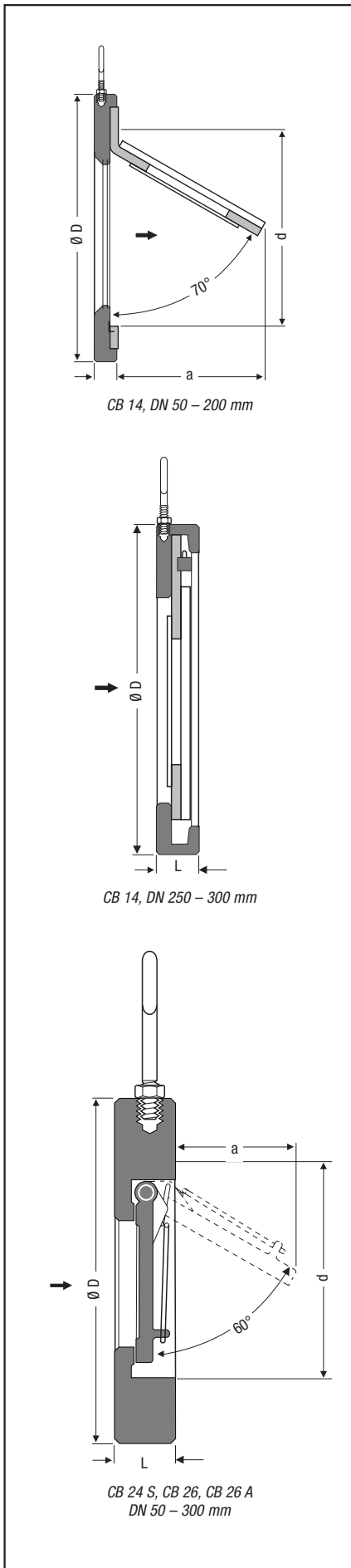

Application and Features

Type	PN	Application for liquids, gases and vapours	Features
CB 14	PN 16	particularly suitable for water and compressed air	rubber-elastic hinge, low weight
CB 24S	PN 16	for salty fluids such as sea water	compact design, 2 bow springs, flap disc with stop for pipe protection, approved by Germanischer Lloyd, CB 24S also approved by Bureau Veritas
CB 26	PN 40	for industrial applications	
CB 26A	PN 40	for low temperatures and aggressive fluids	

Materials

Type	Part designation	Nominal sizes DN	EN reference	ASTM ¹⁾ equivalent
CB 14	Body	50 – 300 mm	1.0460 galvanized	A 105 galvanized
	Flap	50 – 300 mm	NBR	NBR
CB 24 S	Body	50 – 100 mm	Bronze (CC 483K-GS)	B 505 C 90 700
		125 – 300 mm	Bronze (CC 332G)	B 148 Alloy 952
CB 26	Body	50 – 200 mm	1.0460	A 105
		250 – 300 mm	1.0460	A 105
CB 26 A	Body	50 – 150 mm	1.4581	A 351 CF 8 MC
		200 – 300 mm	5.3103	–
		300 mm	1.4581	A 351 CF 8 MC
	Flap	50 – 300 mm	1.4581	A 351 CF 8 MC

¹⁾ Physical and chemical properties comply with EN grade.

Pressure/Temperature Ratings

Type	Nominal sizes DN	PN	p / T / [bar] / [°C]		
CB 14	50 – 300	PN 16	16 / -10	6.0 / 60	4.0 / 80
CB 24 S	50 – 300	PN 16	16 / -200	16.0 / 90	15.6 / 250 ²⁾
CB 26	50 – 150	PN 40	40 / -10	33.6 / 200	25.9 / 350 ²⁾
	200 – 300	PN 40	40 / -10	33.3 / 200	27.6 / 300
CB 26 A	50 – 300	PN 40	40 / -10	35.8 / 200	28.0 / 450 ²⁾³⁾

²⁾ Max. pressure/temperature rating for CB without springs.

³⁾ If the operating temperatures exceed 300 °C intercrystalline corrosion may occur. Do not subject the equipment to operating temperatures higher than 300 °C unless intercrystalline corrosion can be ruled out.

CB Designs

Typ	Seat					Springs	
	metal-to-metal	NBR (-30 up to 110 °C) ⁴⁾	EPDM (-40 up to 150 °C) ⁴⁾	FPM (-25 up to 200 °C) ⁴⁾	PTFE ⁵⁾ (-25 up to 200 °C) ⁴⁾	without spring	special spring
CB 14	–	X ⁶⁾	–	–	–	X	–
CB 24S	0	X	0	0	–	0	–
CB 26	0	–	X	0	0	0	–
CB 26A	0	–	X	0	0	0	–

⁴⁾ Observe pressure / temp. ratings of the equipment

⁵⁾ Cover FPM ring with PTFE

X : standard

⁶⁾ Flap made from NBR (Perbunan) Temp. range: -10 °C up to 80 °C

0 : optional

– : not available

Weights and Dimensions

Nominal size DN [mm]	[in]	Dimensions [mm]								Weight [kg]		
		CB 14				CB 24 S, CB 26, CB 26 A				CB 14	CB 24 S	CB 26 CB 26 A
		D	L	a	d ⁷⁾	D	L	a	d ⁷⁾			
50	2	98	14	45	47	98	17	40	50	0.7	0.9	0.9
65	2½	118	14	60	64	118	20	50	64	1.0	1.4	1.4
80	3	132	14	70	75	132	24	58	75	1.4	2.0	2.0
100	4	154	14	90	98	154	27	72	99	1.5	3.1	3.1
125	5	184	16	115	124	184	32	88	125	2.5	5.2	5.3
150	6	209	16	145	148	209	32	112	144	3.3	6.7	6.9
200	8	264	18	185	196	264	42	150	198	5.5	13.7	14.1
250	10	319	35	220	242	319	47	182	244	11.2	22.9	23.6
300	12	375	43	270	288	375	52	216	292	14.0	32.8	33.8

⁷⁾ Minimum flange bore and inside pipe diameter.

Pressure Drop Charts

The curves given in the chart are valid for water at 20 °C. To read the pressure drop for other fluids the equivalent water volume flowrate must be calculated and used in the graph \dot{V}_w .

The values indicated in the chart are applicable for spring-assisted valves with horizontal flow and to valves without spring installed in vertical pipes with upward flow.

Opening Pressures

Differential pressures at zero volume flow.

Type	DN [mm]	Opening pressures [mbar]		
		Direction of flow		
		↑	→	↓
CB 14	50 – 150	8	0	1)
	200 – 300	15	0	

Type	DN [mm]	Opening pressures [mbar]			
		without spring		with spring	
		↑	→	→	↓
CB 24 S	50 – 150	5	12	7	1)
	200 – 300	8	15	7	
CB 26/	50 – 80	5	12	7	1)
CB 26 A	100 – 150	11	18	7	
	200 – 300	18	25	7	

1) Valves should not be used for downward flow applications, since the spring will not close the valve flap.

Minimum volume flow CB 14

DN	Minimum volume flows [m³]	
	for full opening	
	↑	→
50	12	10
65	18	17
80	29	28
100	42	41
125	55	51
150	140	100
200	260	190
250	460	360
300	610	500

Values refer to water at 20°C.

Minimum volume flow CB 24 S, 26, 26 A

DN	Minimum volume flows [m³]		
	for full opening		
	without spring	with spring	
	↑	↑	→
50	4	6	6
65	7	10	12
80	10	20	20
100	18	30	30
125	30	40	48
150	60	70	80
200	90	150	160
250	160	220	260
300	200	300	360

Values refer to water at 20°C.

$$\dot{V}_w = \dot{V} \cdot \sqrt{\frac{\rho}{1000}}$$

\dot{V}_w = Equivalent water volume flow in [l/s] or [m³/h]

ρ = Density of fluid (operating condition) in [kg/m³]

\dot{V} = Volume of fluid (operating condition) in [l/s] or [m³/h]

CB 14

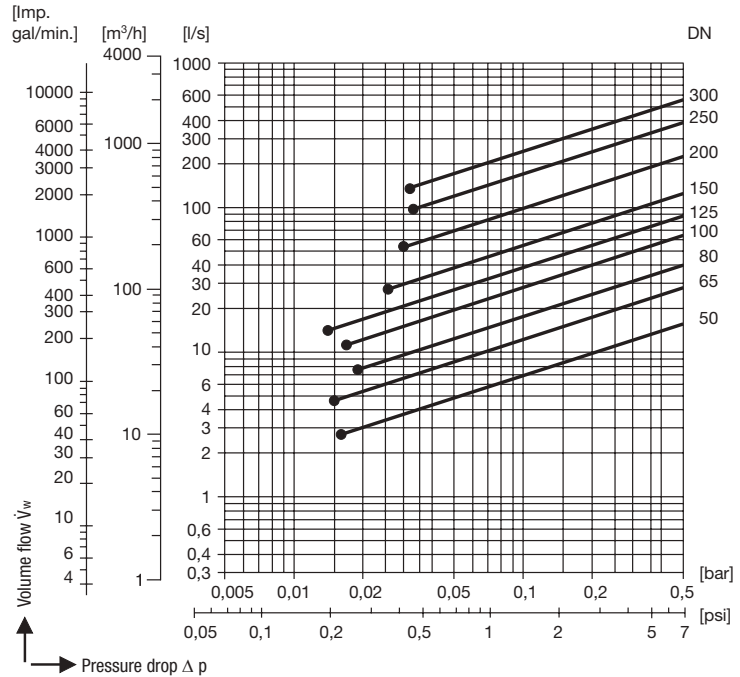

■ Required minimum volume flow \dot{V}_w for equipment installed in horizontal pipes.

CB 24 S, CB 26, CB 26 A

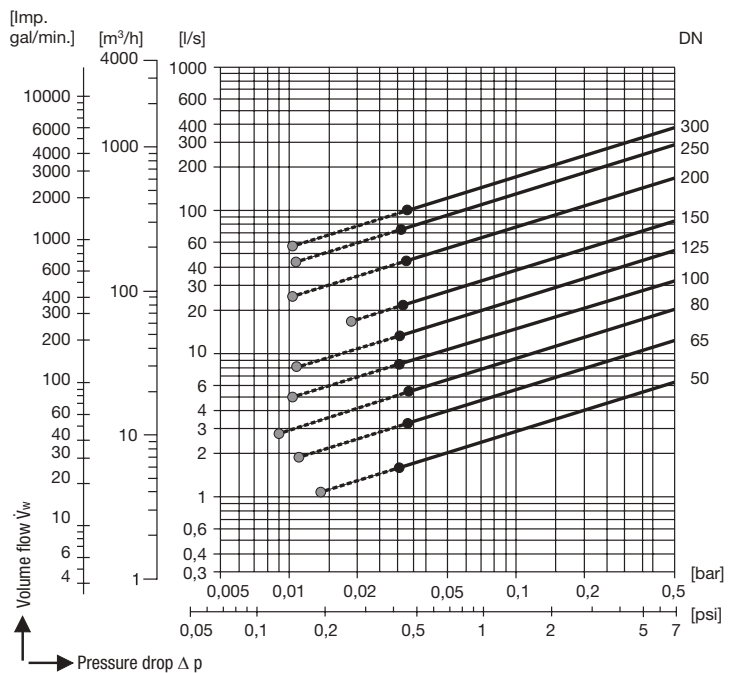

■ Required minimum volume flow \dot{V}_w for equipment without spring installed in vertical pipes with upward flow.

■ Required minimum volume flow \dot{V}_w for equipment with standard spring and horizontal flow.

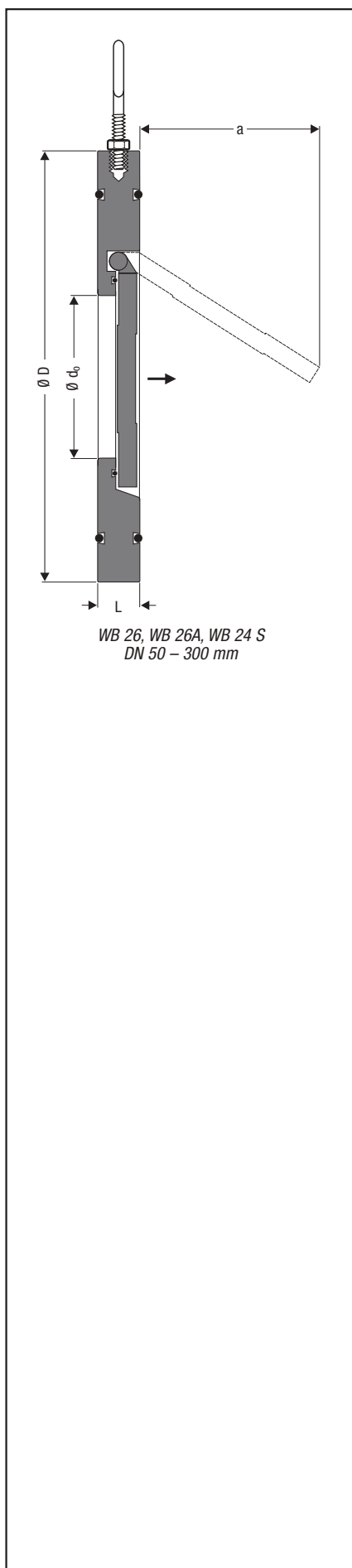

Application and Features

Type	PN	Application	Features
		for liquids, gases and vapours	
WB 24S	PN 16	for salty fluids such as sea water	without spring, eye bolt for easy installation, O-ring of NBR for flange sealing, short overall length
WB 26	PN 16	for industrial applications	
WB 26A	PN 16	for aggressive fluids	

Materials

Type		ASTM reference	EN ¹⁾ equivalent
WB 26	Body	Carbon steel, galvanized	Carbon steel, galvanized
	Flap	AISI 316	1.4401
WB 26 A	Body	AISI 316	1.4401
	Flap	AISI 316	1.4401
WB 24 S	Body and flap	Aluminium bronze	Aluminium bronze
O-rings		NBR as standard	

¹⁾ Physical and chemical properties comply with ASTM grade.

Weights and Dimensions

Nominal size DN		Dimensions [mm]				Weight ⁵⁾ [kg]
[mm]	[in]	L	Ø D	a	Ø d ₀	
50	2	14	109	35	32	0.95
65	2½	14	129	48	40	1.2
80	3	14	144	60	54	1.6
100	4	18	164	78	70	2.5
125	5	18	195	98	92	3.5
150	6	20	220	116.5	112	4.7
200	8	22	275	160	154	7.6
250	10	26	330	200	200	13.2
300	12	32	380	235	240	20.5

⁵⁾ The weight ratings apply for WB 26 and WB 26 A. WB 24 S reduced by approx. 5 %.

Pressure/Temperature Ratings

Nominal pressure	PN	PN 16
Design with O-rings ²⁾		NBR
Max. service pressure	[bar]	16
Related temperature	[°C]	110
Min. temperature ³⁾	[°C]	-10

²⁾ O-rings in flap and valve faces made of NBR as standard.

³⁾ Minimum temperature for nominal pressure rating.

WB Design

Type	Seat					Springs	
	metal-to-metal	NBR (-30 up to 110°C) ⁴⁾	EPDM (-40 up to 150°C) ⁴⁾	FPM (-25 up to 200°C) ⁴⁾	PTFE (-25 up to 200°C) ⁴⁾	without spring	special spring
WB 24S	0	X	Use CB 26	0	-	X	-
WB 26	0	X	Use CB 26	0	Use CB 26	X	-
WB 26A	0	X	Use CB 26A	0	Use CB 26A	X	-

⁴⁾ Observe pressure/temp. ratings

X : standard

0 : optional

- : not available

Pressure Drop Chart

The curves given in the chart are valid for water at 20 °C. To read the pressure drop for other fluids the equivalent water volume flowrate must be calculated and used in the graph \dot{V}_w .

The values indicated in the chart are applicable to equipment installed in horizontal pipes.

$$\dot{V}_w = \dot{V} \cdot \sqrt{\frac{\rho}{1000}}$$

\dot{V}_w = Equivalent water volume flow
in [l/s] or [m³/h]

ρ = Density of fluid
(operating condition) in [kg/m³]

\dot{V} = Volume of fluid (operating
condition) in [l/s] or [m³/h]

Opening Pressures

Opening pressure zero when valve is installed in horizontal line.

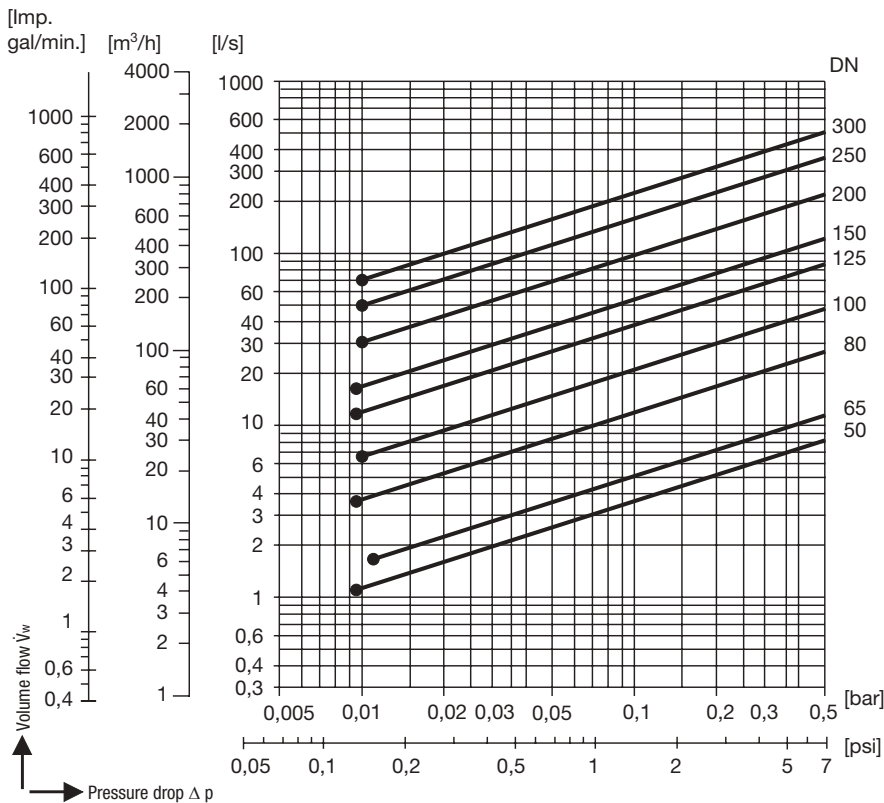

■ Required minimum volume flow \dot{V}_w for equipment installed in horizontal pipes.

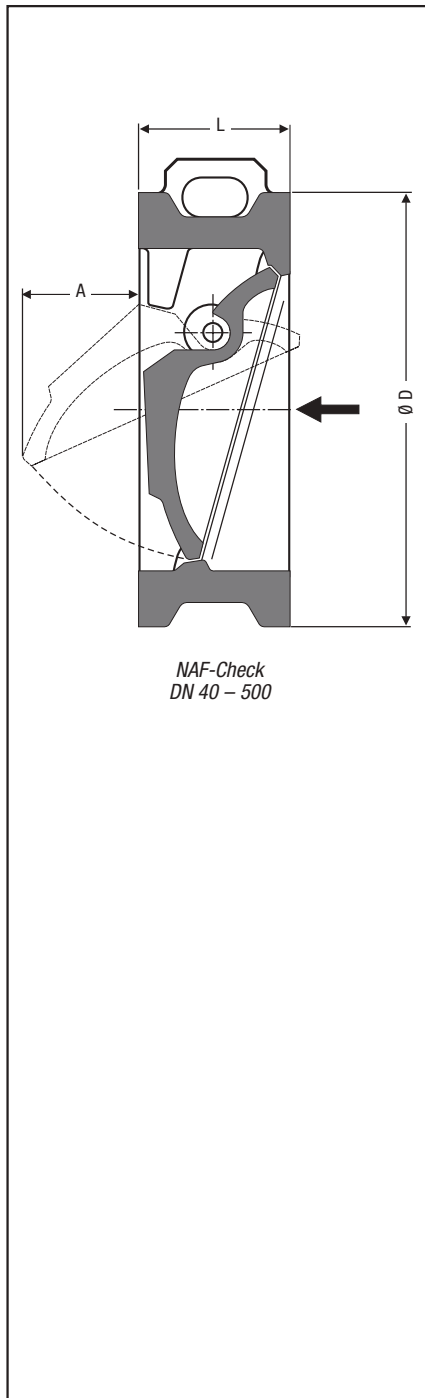

Application and Features

Type	PN	Application	Features
		for liquids, gases and vapours	
NAF-Check	PN 10 – 40	particularly suitable for fibrous media, e. g. in paper industry	excellent hydrodynamic properties, excentric flap suspension, low resistance coefficient

Materials

Design	Part designation	Nominal size DN [mm]	EN / ASME	Equivalent
Steel	Body	40 – 50	1.4404	A316 L
		65 – 200	1.4308	A351 CF8
		250	1.4408	A351 CF8M
		300 – 500	1.0619	ASTMA216 WCB
	Flap	40 + 50	ASTM A487 Gr CA6NM	EN 1.4313
		65 – 500	1.4317	ASTM A743
Stainless steel	Body	40 – 50	1.4406	ASTM A316 L
		65 – 500	1.4408	ASTM A351 CF8M
	Flap	40 – 500	1.4470	ASTM A890

Weight and Dimensions

Type	PN	DN [mm]	Dimensions [mm]			Weight [kg]
			D	L	A	
526 620 ¹⁾ 526 630 ²⁾ 528 620 ¹⁾ 528 630 ²⁾	PN 10 – 40	40	84	33	15	1.2
		50	92	43	5	1.7
		65	108	46	12	1.7
		80	128	64	16	3
		100	158	64	26	5
		125	180	70	36	7
		150	203	76	51	9
		200	263	89	71	16
		250	315	114	90	28
526 520 ¹⁾ 528 530 ²⁾ 528 520 ¹⁾ 528 530 ²⁾	PN 10 – 25	300	370	114	125	41
		350	432	127	146	48
		400	480	140	175	65
		450	530	152	188	94
		500	592	152	228	115

DN 600 – DN 1000 on request

¹⁾ without spring

²⁾ with spring

Pressure/Temperature Ratings

Design	Type	PN	DN [mm]	Max. service pressure [bar] / related temperatures [°C] ³⁾										
				20	100	150	200	250	300	350	400	450	500	525
Steel down to –10 °C at nominal pressure	526 620/30	PN 40	40 – 250	40.0	36.3	32.7	26.9	27.6	25.7	24.5	23.8	–	–	–
	526 520/30	PN 25	300 – 500	25.0	23.2	22.0	20.8	19.0	17.2	16	14.8	–	–	–
Stainless steel ⁴⁾ down to –30 °C at nominal pressure	528 620/30	PN 40	40 – 250	40.0	40.0	36.3	33.7	31.8	–	–	–	–	–	–
	528 520/30	PN 25	300 – 500	25.0	25.0	22.7	21.0	19.8	–	–	–	–	–	–

³⁾ Max. temperature rating for design with spring: + 300 °C.

⁴⁾ If the operating temperatures exceed 300 °C intercrystalline corrosion may occur. Do not subject the equipment to operating temperatures higher than 300 °C unless intercrystalline corrosion can be ruled out.

Pressure Drop Chart

The curves given in the chart are valid for water at 20 °C. To read the pressure drop for other fluids the equivalent water volume flowrate must be calculated and used in the graph \dot{V}_w .

The values indicated in the chart are applicable for spring-assisted valves with horizontal flow and to valves without spring installed in vertical pipes with upward flow.

$$\dot{V}_w = \dot{V} \cdot \sqrt{\frac{\rho}{1000}}$$

\dot{V}_w = Equivalent water volume flow
 in [l/s] or [m³/h]

ρ = Density of fluid
 (operating condition) in [kg/m³]

\dot{V} = Volume of fluid (operating
 condition) in [l/s] or [m³/h]

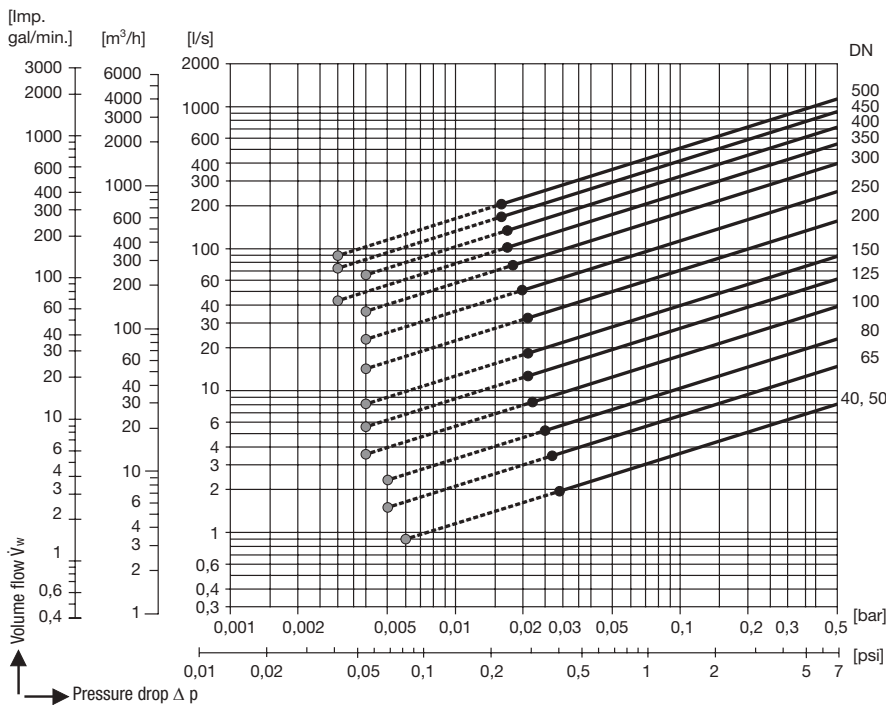

- Required minimum volume flow \dot{V}_w for equipment without spring installed in vertical pipes with upward flow.
- Required minimum volume flow \dot{V}_w for equipment with standard spring and horizontal flow.

E-mail: info@de.gestra.com • Fax: +49 421 3503-393

Online: [www.gestra.com/Service & Support/Questionnaire for preparing offers](http://www.gestra.com/Service%20&%20Support/Questionnaire%20for%20preparing%20offers)

Type of fluid*) _____

Density of fluid _____ kg/m³

Service pressure _____ bar

Service temperature _____ °C

Volume flow _____ Nm³/h m³/h

Maximum admissible pressure drop _____ mbar

Nominal size _____ Pressure rating _____

For installation between

EN flanges ASME flanges _____

Type of non-return / check valves

Non-return valve Swing check valve Dual-plate check valve

Installed in

horizontal pipeline

vertical pipeline with upward flow

vertical pipeline with downward flow

Required inspections / approvals: _____

Your details:

Company
Name / job title
Telephone
Fax
E-mail
Date

*) If the fluid is not water a detailed analysis (concentration, solid matter, pH value etc.) is required.

DISCOCHECK Dual-Plate Check Valves BB

These top-quality dual-plate check valves considerably reduce operating costs by providing reliable, wear-resistant operation for extended service life and, at the same time, requiring little maintenance and low expenditure of pump wear.



- A4 Return-Temperature Control Valves**
- A4 Self-Acting Pressure and Temperature Controllers**
- A4 Control Valves**
- A6 Safety Valves**
- A7 Strainers**
- A8 Stop Valves**

	Page
Return-Temperature Control Valves	
Cooling-Water Control Valves CW GESTRAMAT	64 – 65
Return-Temperature Control Valves BW KALORIMAT	66 – 68
Self-Acting Pressure and Temperature Controllers	
Pressure-Reducing Valves 5801	69
Pressure-Maintaining Valves 5610	70
Self-Acting Temperature Controllers	71 – 73
Control Valves	
Single-Seat Control Valves with Electric or Pneumatic Actuator	74
Control Valves ZK with Radial Stage Nozzle	75 – 78
Questionnaire for sizing ZK valves with radial stage nozzle	79
Safety Valves GSV	80
Strainers GSF, SZ	81 – 82
Stop Valves GAV	83 – 84

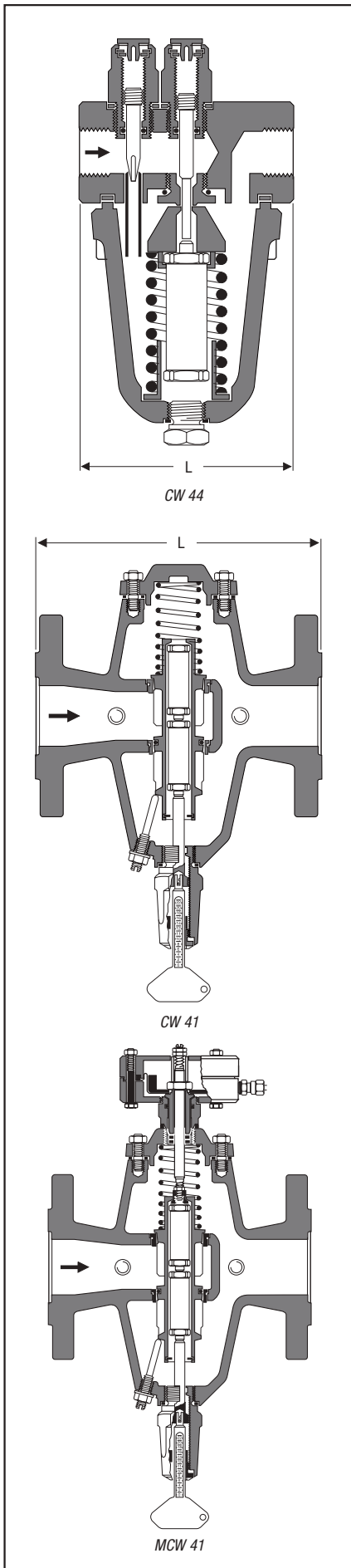

Features of the CW Series

- Direct acting proportional controller for regulating the cooling-water return temperature.
- Reduced capital costs (for new plants) coolant and energy consumption due to higher discharge temperatures
- The valve prevents short-circuiting and automatically balances large systems.
- Straight-through body with solid-state expansion thermostat and setting device.
- Standard valve type CW 41 with pressure gauge (0–6 bar) and thermometer (–30 to +100 °C).
- MCW 41 = CW 41 with diaphragm actuator. (Retro-fitting of diaphragm actuator possible).

Application

CW 41	for industrial cooling water
CW 44	
CW 41/4	for saline fluids, ammoniacal cooling water and chlorinated hydrocarbons (wetted internal parts made from stainless steel)
CW 44 k	
MCW 41	for heavily contaminated cooling systems

Specification *)

Type	PN	ΔP [bar]	Material		Pressure/Temperature		
			EN	ASTM	PS [bar]	TS ²⁾ [°C]	p / T ²⁾ [bar / °C]
CW 41	16	6	5.3103	A 395 ¹⁾	16	– 10 / 110	16 / 110
CW 41/4	16	6	5.3103	A 395 ¹⁾	16	– 10 / 110	16 / 110
CW 44	25	16	1.0460	A 105 ¹⁾	25	– 2 / 120	25 / 110
CW 44 K	25	16	1.0460	A 105 ¹⁾	25	– 10 / 85	25 / 85

1) ASTM nearest equivalent grade is stated for guidance only.
Physical and chemical properties comply with EN.

2) Temperature that is admissible for only a short time depends on type of thermostat:
n-thermostat 110 °C, w-thermostat 100 °C, k-thermostat 85 °C

*) For more information on pressure/temperature ratings and end connections see data sheets.

Temperature Ratings

Type	Thermostat / cone combination	Adjustment range
CW 41	wr or ws	20 °C – 60 °C
CW 41/4	nr or ns	3 °C – 100 °C
	kr or ks	–32 °C – 74 °C
CW 44	n	–2 °C – 106 °C
CW 44 K	k	–37 °C – 71 °C

w = wax thermostat r = reduced cone for small flowrates
n = standard thermostat s = standard cone for large flowrates
k = thermostat for brine

End Connections and Overall Lengths

Type	End connection	Overall length L [mm]							
		DN 10	DN 15	DN 20	DN 25	DN 40	DN 50	DN 80	DN 100
		3/8"	1/2"	3/4"	1"	1 1/2"	2"	3"	4"
CW 41	Flanged EN PN 16	–	–	–	160	200	230	310	350
CW 41/4	Flanged EN PN 16	–	–	–	160	200	230	310	350
CW 44	Screwed sockets	95	95	95	95	–	–	–	–
CW 44 K	Screwed sockets	95	95	95	95	–	–	–	–

Flowrates (k_v values)

Type	Cone		DN 25	DN 40, DN 50	DN 80, DN 100	
CW 41	r	K _{VS} value [m ³ /h]	2.1	6.5	20	
CW 41/4		K _{VO} (Preset bleed flow) [m ³ /h]	0.12	0.31	1.0	
	s	K _{VS} value [m ³ /h]	10.5	31	98	
		K _{VO} (Preset bleed flow) [m ³ /h]	0.55	1.5	5.0	
			G 3/8	G 1/2	G 3/4	G 1
CW 44	–	K _{VS} value [m ³ /h]	0.66	0.66	1.37	1.37
CW 44 K	–	K _{VO} (Preset bleed flow) [m ³ /h]	0.04	0.04	0.04	0.04

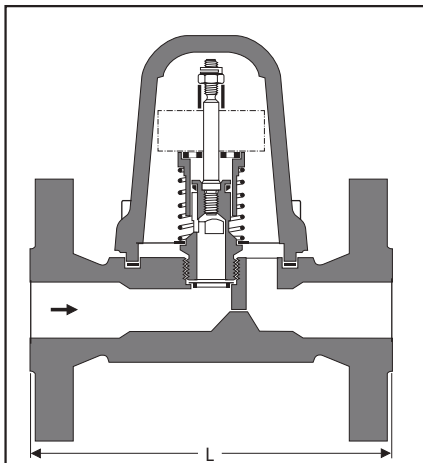

BW 31, DN 15–25 mm

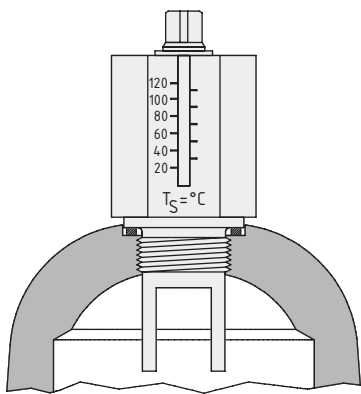

External setting device
for BW 31

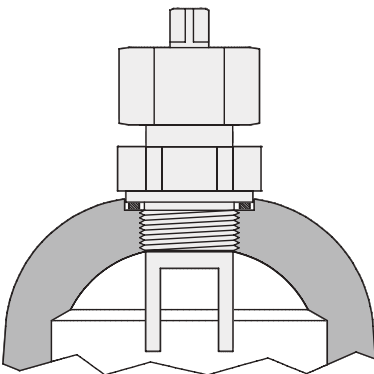

External setting device
for BW 31A

Features of the BW series

- Direct acting proportional controller for maintaining constant return temperatures.
- Used for regulating large heating systems and tracing systems, or for the temperature control of individual heat exchangers (washing baths, chemical and galvanic baths).
- Also suitable for a supply system tailored to the needs of consumers that are installed in parallel.
- Straight-through valve with balanced valve sleeve. Closing temperature set at our works.
- Valves with external setting device available on request.

Application

BW 31	for hot water
BW 31 A	for thermal oils

Specification *)

Type	DN	PN	ΔP [bar]	Material		Pressure / Temperature		
				EN	ASTM	PS [bar]	TS [°C]	p / T [bar / °C]
BW 31	15-25	40	6	1.0460	A 105 ¹⁾	40	400	23.1 / 400
BW 31	40	25	6	1.0460	A 105 ¹⁾	25	400	14.4 / 400
BW 31A	15-25	40	6	1.0460	A 105 ¹⁾	40	400	23.1 / 400
BW 31A	40	25	6	1.0460	A 105 ¹⁾	25	400	14.4 / 400

1) ASTM nearest equivalent is stated for guidance only.
Physical and chemical properties comply with EN.

*) For more information on pressure/temperature ratings and end connections see data sheet.

End Connections and Overall Lengths L

Type	Connections	Overall length L [mm]			
		DN 15	DN 20	DN 25	DN 40
BW 31	Flanged EN PN 25	150	150	160	200
	Flanged ASME 150	150	150	160	215
	Screwed sockets	95	95	95	130
BW 31A	Flanged EN PN 25	150	150	160	200
	Flanged ASME 150	150	150	160	216
	Screwed sockets	95	95	95	130

Closing temperatures (without external setting device)¹⁾

Type	Adjustable range	DN 15 mm	DN 20 mm	DN 25 mm	DN 40 mm
		1/2"	3/4"	1"	1 1/2"
BW 31		20 °C - 130 °C	20 °C - 115 °C	20 °C - 115 °C	20 °C - 110 °C
BW 31A		120 °C - 270 °C	100 °C - 280 °C	100 °C - 280 °C	100 °C - 270 °C

1) A fixed closing temperature can only be adjusted within the indicated adjustment range in steps of 5 °C.

Adjustable closing temperatures (with standard external setting device)

BW 31	60 °C - 130 °C	40 °C - 115 °C	40 °C - 115 °C	50 °C - 110 °C
BW 31A	90 °C - 270 °C	70 °C - 270 °C	70 °C - 270 °C	70 °C - 270 °C

Adjustable closing temperatures (with special external setting device)

BW 31	20 °C - 110 °C	20 °C - 90 °C	20 °C - 90 °C	20 °C - 75 °C
BW 31A	60 °C - 160 °C	30 °C - 170 °C	30 °C - 170 °C	25 °C - 85 °C

Capacity Charts

Δt = temperature difference in Kelvin [K] between closing temperature (temperature at which the valve is closed) and return temperature.

BW 31, DN 15

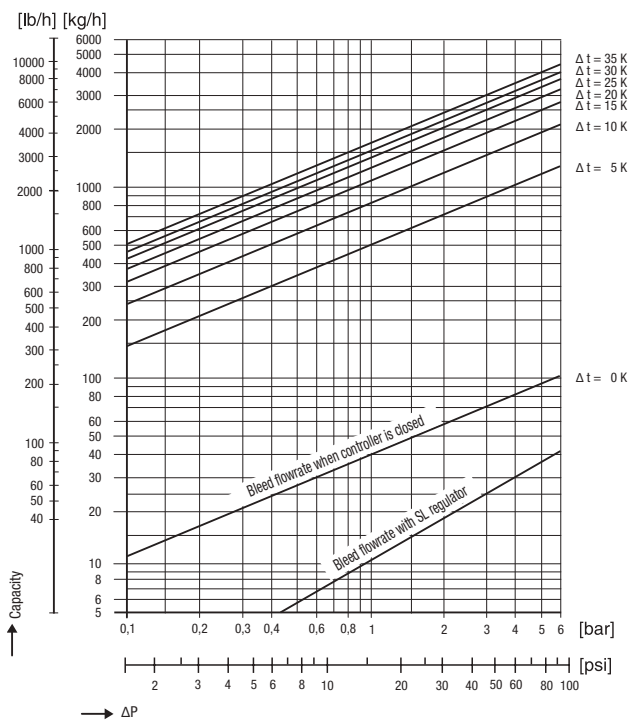

BW 31, DN 20 and 25

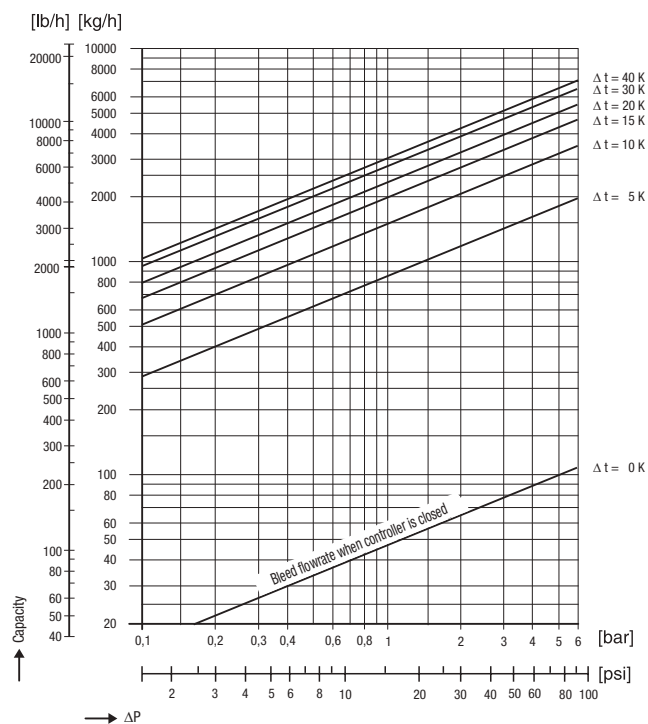

BW 31, DN 40

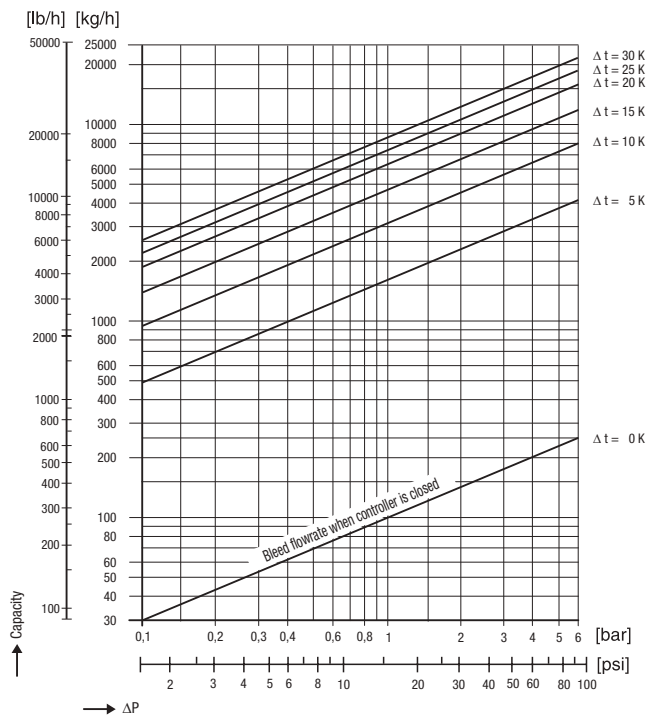

Capacity Charts

Δt = temperature difference in Kelvin [K] between closing temperature (temperature at which the valve is closed) and return temperature.

BW 31A, DN 15

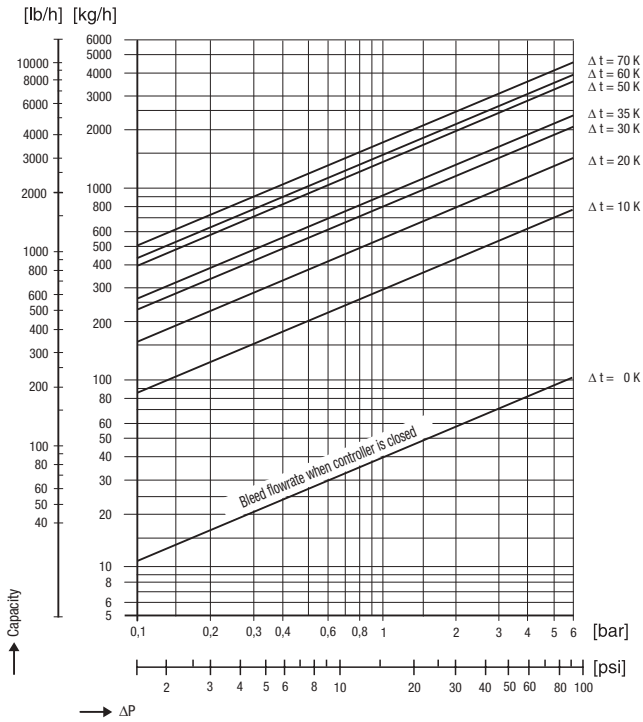

BW 31A, DN 20 and 25

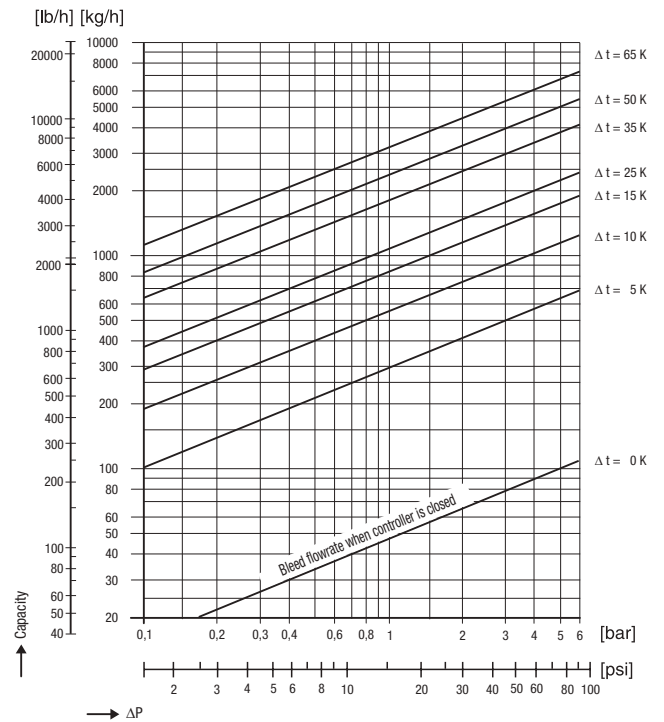

BW 31A, DN 40

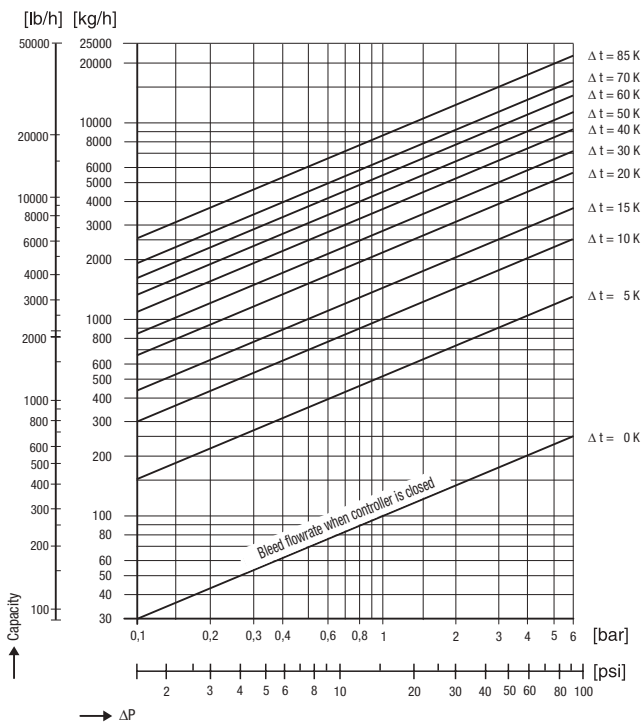

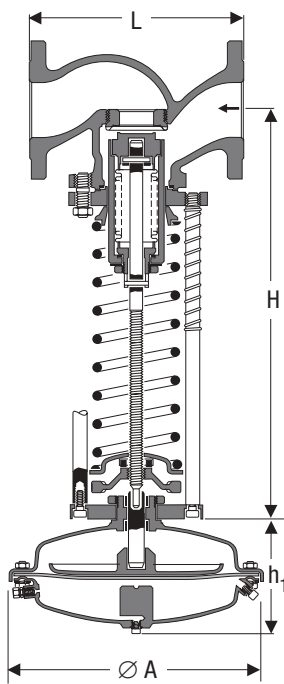

Pressure-reducing valve 5801

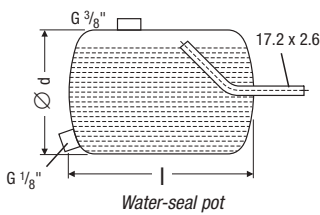

Water-seal pot

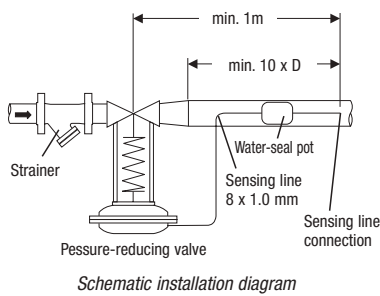

Schematic installation diagram

Application

Type 5801 Pressure-reducing valve for use with steam and other fluids.
In all energy and process systems.

Design

The pressure-reducing valve is a balanced single-seat proportional controller operating without auxiliary energy.
The pressure-reducing valve consists of a body with internals, bellows, spring, handwheel and actuator. For steam and liquids at temperatures above 100 °C a water-seal pot is required to protect the actuator diaphragm.

Dimensions [mm] and Weights [kg] of Valve Body

DN	15	20	25	32	40	50	65	80	100	125	150	200
L	130	150	160	180	200	230	290	310	350	400	480	600
H	390	390	390	408	425	500	505	590	590	705	725	760
Weight 0.7043	7	8	9	12	14	18	26	40	50	77	112	170
Weight 1.0619	7	8	9	12	14	19	27	40	54	82	115	176
Weight 1.4581	7	8	9	12	14	19	27	40	54	82	115	176

Dimensions [mm] and Weights [kg] of Actuator

Actuator	A11	A2	A3	A4	A51	A61	B11	B2
Ø A	150	160	195	270	355	510	150	160
h ₁	90	100	100	120	165	200	90	110
Approx. weight	2.8	4.5	6.0	4.5	10	27.5	3.5	5.5

Dimensions [mm] and Weights [kg] of Water Pot Seal

Size	l	d	Size DN	Weight
1	206	88.9	15 – 65	1.7
2	172	152.4	80 – 100	3.5
3	250	152.4	125 – 200	4.9

Schematic Representation of a Compact-Design Pressure Reducing Station

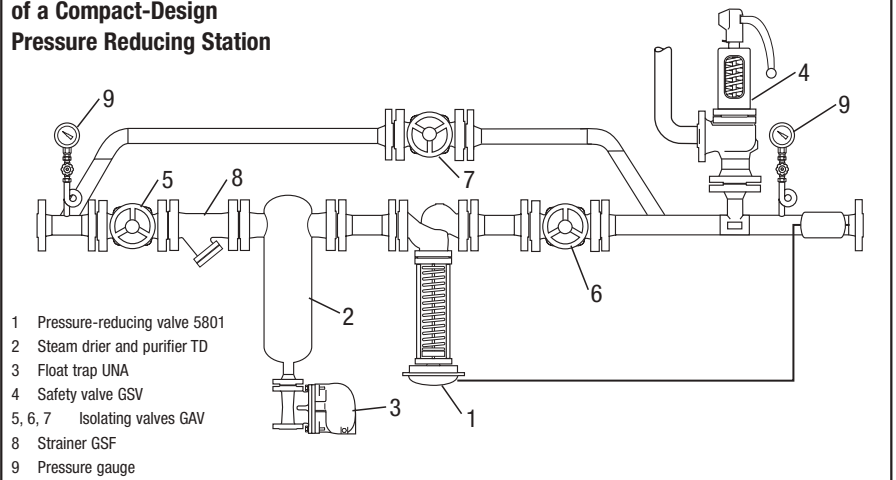

- 1 Pressure-reducing valve 5801
- 2 Steam drier and purifier TD
- 3 Float trap UNA
- 4 Safety valve GSV
- 5, 6, 7 Isolating valves GAV
- 8 Strainer GSF
- 9 Pressure gauge

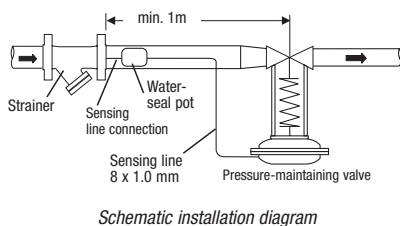
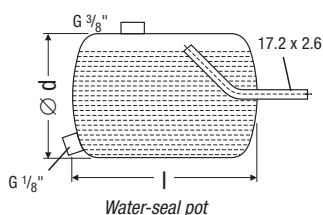
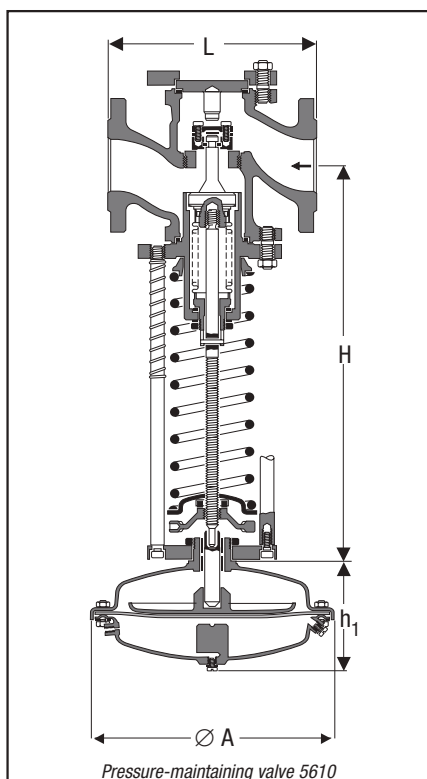

Application

Type 5610 Pressure-maintaining valve for maintaining upstream pressures independent of downstream pressures for use with steam, gases and liquids.

Design

The pressure-maintaining valve is a self-acting proportional controller with single-seat and balanced valve.

The pressure-maintaining valve consists of a body with internals, bellows, spring, handwheel and actuator. For steam and liquids at temperatures above 100 °C a water-seal pot is required to protect the actuator diaphragm.

Dimensions [mm] and Weights [kg] of Valve Body

DN	15	20	25	32	40	50	65	80	100
L	130	150	160	180	200	230	290	310	350
H	405	405	405	410	425	495	500	590	590
Approx. weight	10	11	12	14	18	23	35	48	70

Dimensions [mm] and Weights [kg] of Actuator

Actuator	A11	A2	A3	A4	A51	B11	B2
Ø A	150	160	195	270	355	150	160
h ₁	90	100	100	120	165	90	110
Approx. weight	2.8	4.5	6.0	4.5	10	3.5	5.5

Dimensions [mm] and Weights [kg] of Water-Seal Pot

Size	l	d	Size DN	Weight
1	206	88.9	15 – 65	1.7
2	172	152.4	80 – 100	4.9

Diagrammatic layout of pressure-maintaining control unit with flash-vessel

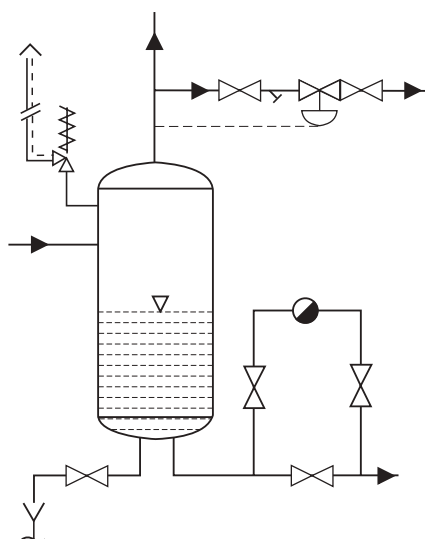

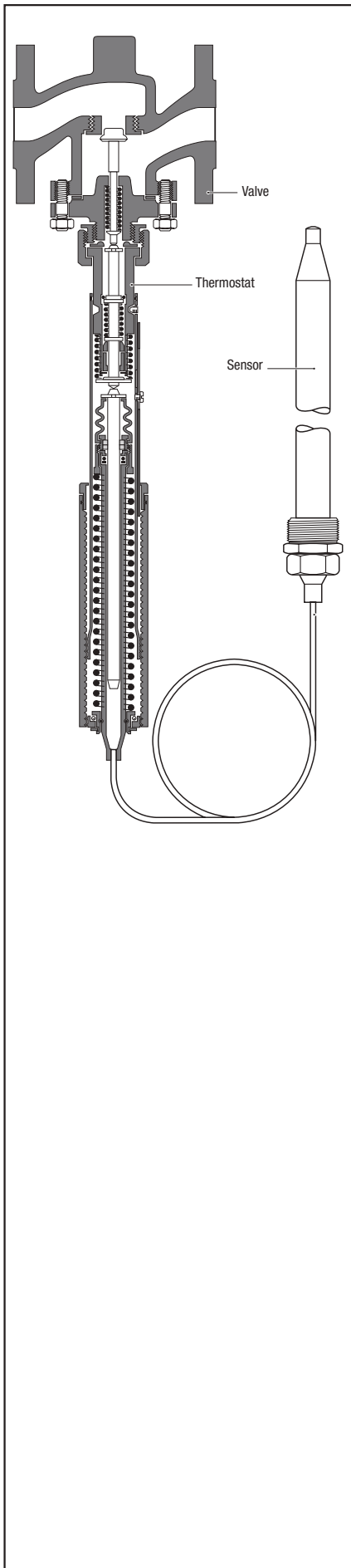

Application

Temperature control in heating and cooling processes in industrial plants, for h.v.a.c services and marine engineering. For liquids, gases, vapours.

Design

The self-acting temperature controller consists of a valve featuring a thermostat and a sensor. According to the service conditions the controller is optionally equipped with a cooling unit or a sensor pocket.

The temperature sensed by the sensor changes the volume of the measuring liquid in the capillary tube. The resulting pressure acts directly on the actuating piston which, in turn, operates the valve spindle. As the temperature rises, the regulating valve is held in closed position (heating process) or open position (cooling process) until the pre-set release temperature is reached.

When the temperature drops again, a built-in return spring resets the valve to original position.

Valves

Two-way valves, with single seat or pressure-balanced single/double seat. Double-seated, two-way reverse-acting valves or three-way valves for diverting and mixing applications. Valve components made of gunmetal, cast iron, nodular cast iron or cast steel, with flanged or screwed connections.

Thermostat

The thermostat is firmly attached to the sensor capillary tube. The rod-, spiral- or airduct-type sensors are made of copper or high-alloy stainless steel.

The capillary tube is available in different lengths, made of copper or high-alloy stainless steel.

Examples of Industrial Process Applications

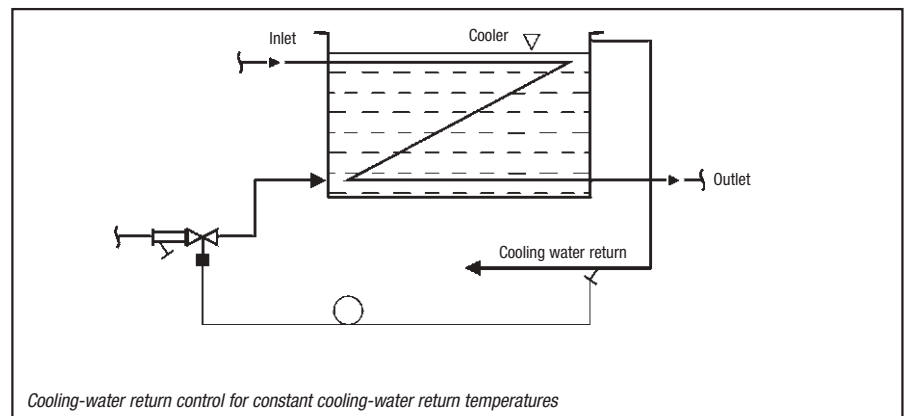
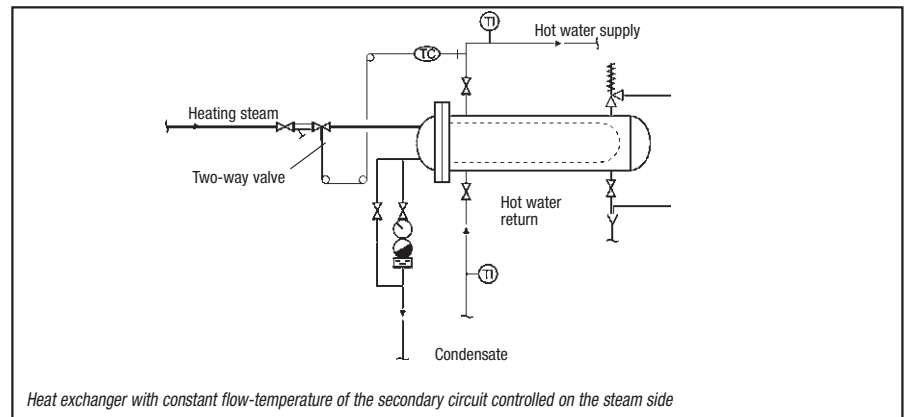

Dimensions [mm] and Weights [kg] for Valves and Thermostats

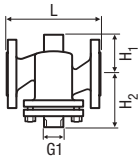
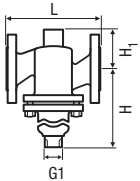
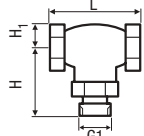
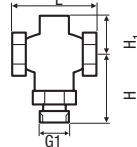
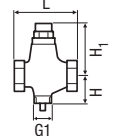
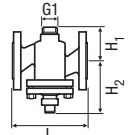
Valve type	DN	15	20	25	32	40	50	65	80	100	125	150	
	G	½	¾	1	1¼	1½	2						
M1F G1F H1F 	L	130	150	160	180	200	230						
	H ₁	80	85	95	105	110	125						
	H ₂	60	65	70	75	85	95						
	M1F/G1F	kg	3.1	4.2	5.5	8.1	9.7	14.7					
	H1F	kg	3.4	4.6	6.1	9.0	10.8	15.5					
M1FBN G1FBN H1FBN 	L	130	150	160	180	200	230	290	310				
	H	101	107	112	122	125	140	154	164				
	H ₁	80	85	70	75	85	95	110	115				
	M1FBN	kg	4	5	6.0	9.0	13.0	16.0	23.0	38.0			
	G1FBN	kg	4	5	6.0	9.0	13.0	16.0	23.0	38.0			
	H1FBN	kg	4	5	6.0	9.0	13.0	16.0	23.0	38.0			
L1S 	L	85	95										
	H	65	67										
	H ₁	20	32										
		kg	0.7	0.8									
L2S 	L					129	153						
	H					118	122						
	H ₁					68	71						
		kg					2.9	3.8					
L2SR 	L					129	153						
	H					65	70						
	H ₁					90	94						
		kg					3.0	4.0					
M2FR G2FR H2FR 	L		150	160	180	200	230	290	310	350	400	400	
	H ₁		63	70	75	85	95	110	155	145	160	180	
	H ₂		112	117	151	155	163	180	195	240	260	293	
		kg		5.0	6.5	9.0	11.0	16.0	21.0	35.0	39.0	75.0	77.0

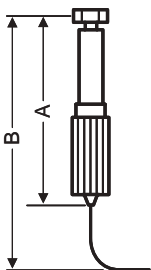
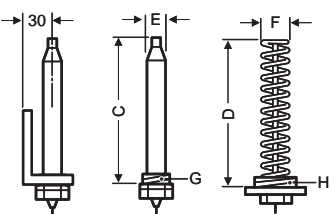
Thermostats	Type V 2.05		Type V 4.03		Type V 4.05		Type V 4.10		Type V 8.09		Type V 8.18		
	K	N	K	N	K	N	K	N	K	N	K	N	
Adjusting cylinder 	A	305	305	385	385	385	385	385	385	560	560	560	
	B	405	405	525	525	525	525	525	525	740	740	740	
Rod- and spiral-type sensor with BSP connection 	C	210	190	210	190	390	380	490	515	710	745	800	
	D	235	170	235	170	235	250	325	325	425	435	810	
	E	22	22	22	22	22	22	28	25	28	25	34	
	F	49	49	49	49	49	49	49	49	49	49	49	
	G	¾	¾	1	1	1	1	1	1	2	2	2	
	H	2"	2"	2"	2"	2"	2"	2"	2"	2"	2"	2"	2"
		kg	1.8	1.8	2.4	2.4	2.6	2.6	3.3	3.3	6.3	6.3	7.3
		kg	2.3	2.3	2.9	2.9	3.1	3.1	3.8	3.8	6.3	6.3	7.3

Closing Pressure Ratings for Valves and Sensors

Single-seated regulating valves with flanged ends and rod-type copper sensor with copper capillary tube (3 m)

	DN [mm]	15/6	15/9	15/12	15	20	25	32	40	50	65	80
	k_{vs} value	0.45	0.95	1.7	2.75	5	7.5	12.5	20	30	50	80
Δp_{max} for sensor type	2.05	20	13	9.3	5.3	1.9	0.9	–	–	–		
Fluid: saturated steam	4.05	40	38	24	15	6.7	–	–	–	–		
Type M1F, G1F, H1F	4.10	–	–	–	–	–	4.1	1.9	0.8	–		
	8.09	–	–	–	–	16	10	5.8	3.3	2.3		

Balanced, single-seated regulating valves with flanged ends and rod-type copper sensor with copper capillary tube (3 m)

	DN				15	20	25	32	40	50	65	80
	k_{vs} value				4	6.3	10	16	25	35	58	80
Δp_{max} for sensor type	4.05				16	16	16	16	9	8	6	4
Fluid: saturated steam	4.10				16	16	16	16	9	8	6	4
Type M1FBN, G1FBN, H1FBN	8.09				16	16	16	16	16	16	16	16
	8.18				16	16	16	16	16	16	16	16

Single-seated regulating valves with screwed end connection and rod-type copper sensor capillary tube (3 m)

	BSP	1/2 / 6	1/2 / 9	1/2 / 12	1/2	3/4						
	k_{vs} value	0.45	0.95	1.7	2.75	5						
Δp_{max} for sensor type	2.05	16	16	–	6	2.9						
Fluid: saturated steam	4.05	16	16	–	16	9						
Type L 1S	4.10	16	16	–	16	9						

Double-seated regulating valves with screwed connection and rod-type copper sensor with copper capillary tube (3 m)

	BSP	1/2 / 6	1/2 / 9	1/2 / 12	1/2	3/4	1	1 1/4	1 1/2	2		
	k_{vs} value	0.45	0.95	1.7	2.75	5	7.5	12.5	20	30		
Δp_{max} for sensor type	2.05	–	–	–	–	–	–	–	–	–		
Fluid: water < 120 °C	4.10	–	–	–	–	–	–	–	21	14		
Type L 2S												

Double-seated reverse-acting valve with screwed connection and rod-type copper sensor with copper capillary tube (3 m)

	BSP	1/2	3/4	1	1 1/4	1 1/2	2
	k_{vs} value	2.75	5	7.5	12.5	20	30
Δp_{max} for sensor type	2.05	–	–	–	–	–	–
Fluid: water < 120 °C	4.05	–	–	–	–	–	–
Type L2SR	4.10	–	–	–	–	2.7	1.8

Double-seated reverse-acting valve with flanged ends and rod-type copper sensor with copper capillary tube (3 m)

	DN [mm]	20	25	32	40	50	65	80	100	125	150
	k_{vs} value	5	7.5	12.5	20	30	50	80	125	215	310
Δp_{max} for sensor type	2.05	8.3	8	–	–	–	–	–	–	–	–
Fluid: water < 120 °C	4.05	8.3	8	7	–	–	–	–	–	–	–
Type M2FR, G2FR, H2FR	4.10	–	–	–	6.6	5.3	5.8	6.7	–	–	–
	8.09	–	–	–	–	–	–	–	12.1	–	–
	8.10	–	–	–	–	–	–	–	12.1	9	7.5



Three-way valves available on request.

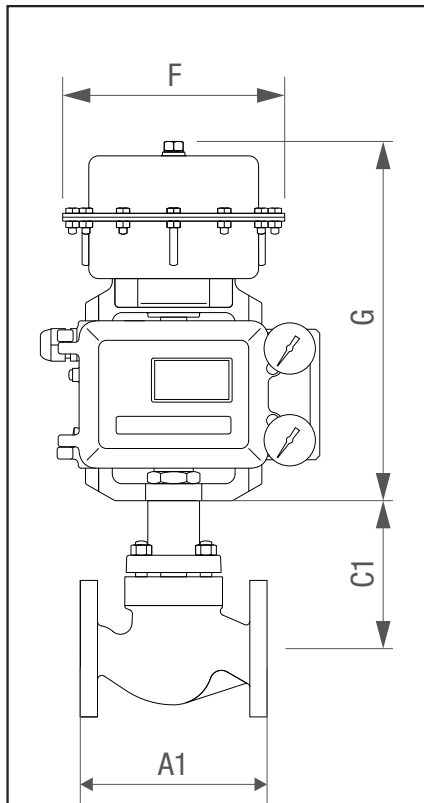

Pneumatic Actuators

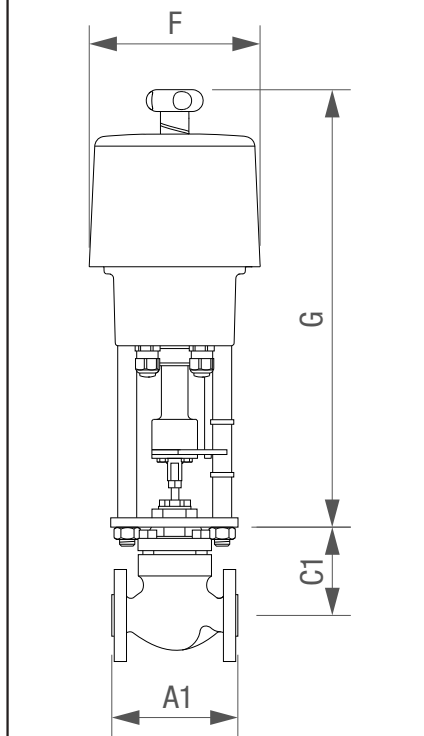

Electric Actuators

k _{vs} (m ³ /h)	DN [mm]	Lift [mm]	Pneumatic actuator				Electric actuator			
			PN9123E	PN9223E	PN9233E	PN9337E	AEL-51211JXA	AEL-53211JXA	AEL-54211JXA	AEL-55311JXA
4	15	20	40	40			40			
6.3	20		40	40			35			
10	25		39.1	40			23	40		
16	32		30.7	40			18	40	40	
25	40		11.5	40			7.9	38.8	40	
36	50		7.5	37.7			5.6	27.6	40	40
63	65	30			20.2	40		15.3	27.7	40
100	80				12.4	34.9		9.8	17.7	31.3
160	100				7.3	21.3		6.1	11	19.5

DN	A1	C1	Thread for actuator	Weight
15	130	103	M8	6
20	150	103		6.8
25	160	103		7
32	180	132		13.5
40	200	132		14
50	230	127		17
65	290	201	M12	35
80	310	201		40
100	350	216		54

	Pneumatic actuator				Electric actuator			
	PN9123E	PN9223E	PN9233E	PN9337E	AEL-51211JXA	AEL-53211JXA	AEL-54211JXA	AEL-55311JXA
F	170	300	300	390	177	177	177	180
G	275	300	300	335	459	459	490	557
Weight	6	17	17	27	5	5	7	10



ZK 29/14 DN 50 with lift restriction (optional extra)

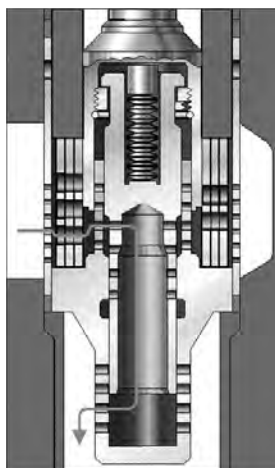

Radial stage nozzle with tandem shut-off
for ZK 213

Application

For the decrease of high pressure drops in industrial plants and power stations as:

- Level control valve
- Warm-up valve
- Level control valve
- Injection cooling valve
- Feedwater control valve
- Leak-off valve
- Start-up pot drain valve
- And more applications

Features

- Extremely wear resistant
- Excellent sealing and control characteristic (EN 12266-1 leakage rate A)
- Variable valve characteristics (linear and equal-percentage)
- Easy assembly and inspection of nozzle insert
- Tandem shut-off for ZK 313 and ZK 213
- Low sound level
- Different actuators available

Materials

Type	Body ¹⁾	
ZK 29, DN 25, 50	13 CrMo 4 4	(1.7335) / A182 F12
ZK 29, DN 80, 100, 150	GS-17 CrMo 5 5	(1.7357) / A 217 WC6
ZK 210	13 CrMo 4 4	(1.7335) / A 182 F12
ZK 313	16 Mo 3	(1.5415)
	C 22.8	(1.0460) / A 105
	10 CrMo 9 10	(1.7383) / A182 F22
	X 10 CrMo VNb 9 1	(1.4903) / A182 F91
ZK 213	16 Mo 3	(1.5415)
	WB 36	(1.6368)
ZK 610 / 613	16 Mo 3	(1.5415)
	10 CrMo 9 10	(1.7383)

¹⁾ Butt-weld ends of other material by welding of pipe ends possible.

Actuators

Type	ZK 29	ZK 210	ZK 313	ZK 213	ZK 610 ZK 613
Handwheel	●	●	●	–	–
Electric rotary actuator	●	●	●	●	●
Electric linear actuator	●	●	●	●	●
Electro-hydraulic linear actuator	–	–	●	●	●
Pneumatic actuator	●	●	●	●	●
Part-turn actuator	●	–	●	●	●

Controls

Complete PLC-based controls for applications such as injection cooler, leak-off valve etc. designed and manufactured according to customers' specifications.

Technical Data

Kv_S -values [m³/h] (linear characteristics), design, pressure/temperature ratings

ZK 29				
DN	Δp 100 bar			
25	0.7	1.4	2.1	
50	3	6	9	
65				
80	14	21	28	
100	20	33	46	
125				
150	70	100	130	
200				
250				
300				
350				
400				

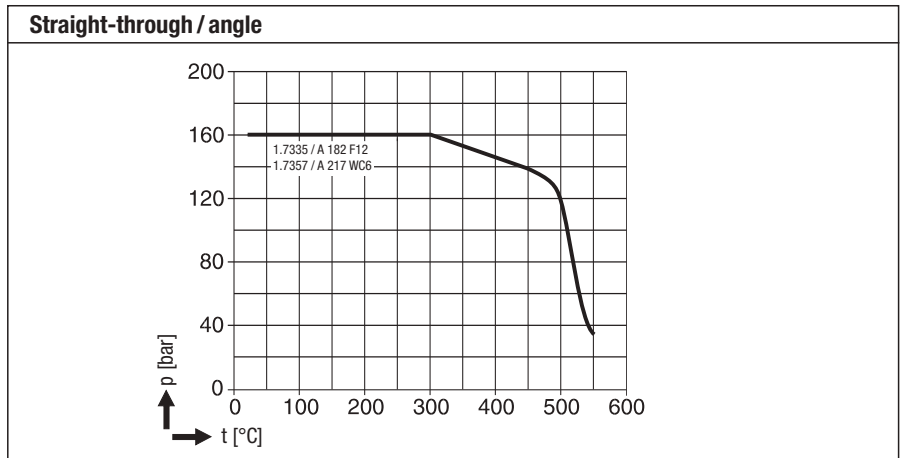

ZK 210				
DN	Δp 100 bar			Δp 180 bar
25	0.8	1.5	2.3	0.5
50	3.3	6.5	10	2
65				
80	9.5	18	28	5
100				
125				
150				
200				
250				
300				
350				
400				

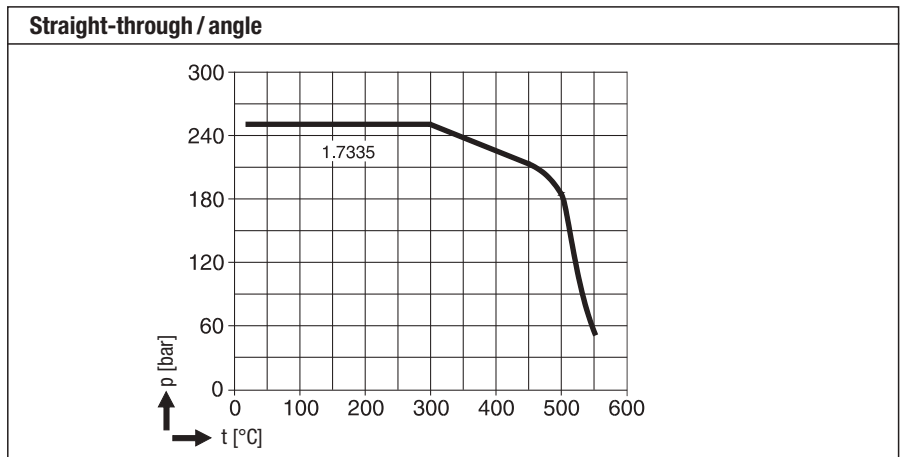

ZK 213 sizes 1-5											
DN	Δp 300 bar					Δp 560 bar					
	Bg.	1	2	3	4	5	1	2	3	4	5
25											
50											
65											
80	13					10					
100	13	26				10	20				
125	13	26	39			10	20	30			
150		26	39	60			20	30	46		
200			39	60	90			30	46	70	
250				60	90				46	70	
300					90					70	
350											
400											

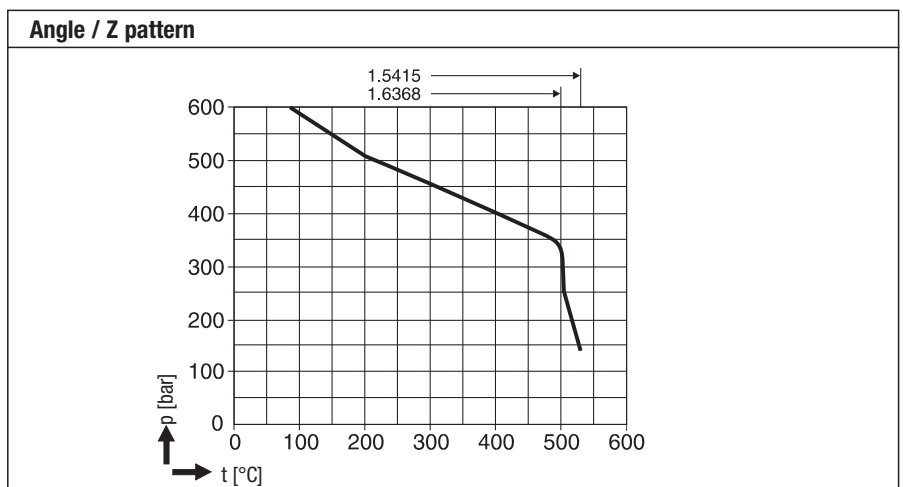

Adaptation of nominal sizes is possible

Technical Data

Kv_S -values [m³/h] (linear characteristics), design, pressure/temperature ratings

ZK 313											
DN	Δp 300 bar								Δp 370 bar		
25	1	1.5	2.3	3.6	5.5	8	11	13	4.5	9.5	
50	1	1.5	2.3	3.6	5.5	8	11	13	4.5	9.5	
65	1	1.5	2.3	3.6	5.5	8	11	13	4.5	9.5	
80	1	1.5	2.3	3.6	5.5	11	14.5	17	4.5	9.5	
100						11	14.5	17	4.5	9.5	
125						11	14.5	17	4.5	9.5	
150						11	14.5	17	4.5	9.5	
200											
250											
300											
350											
400											

Straight-through / angle DN 25–80

Angle / Z pattern up to DN 80

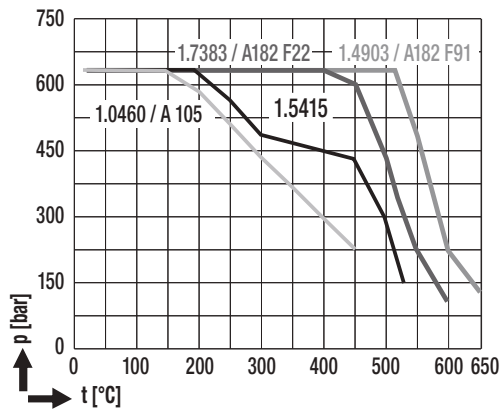

Throttle variants ZK 313

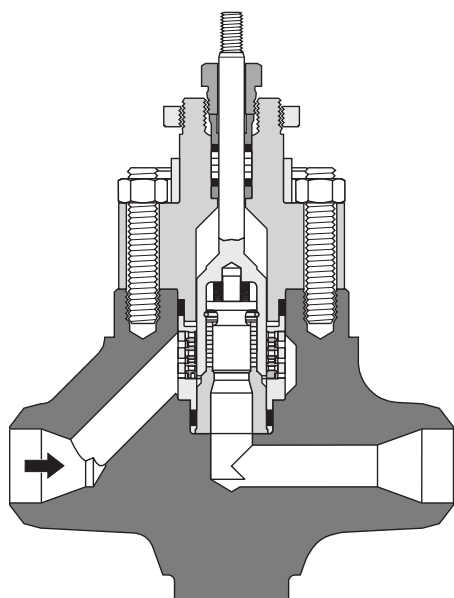

Standard throttle Δp_{max} 300 bar

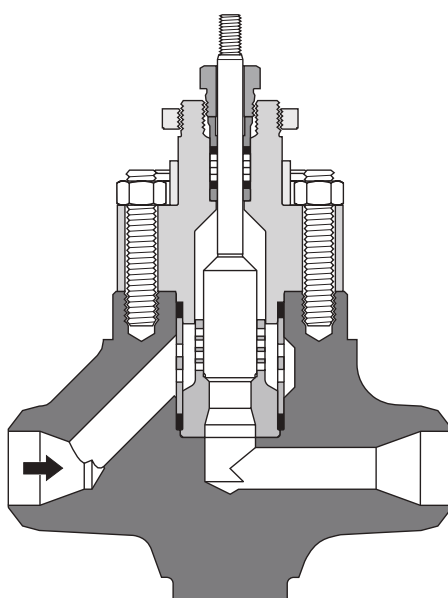

Special throttle Δp_{max} 40 bar
(without tandem seat)

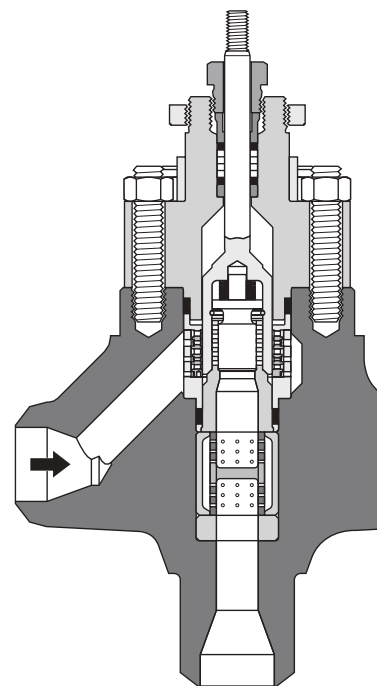

Special throttle Δp_{max} 370 bar
(only angle-type)

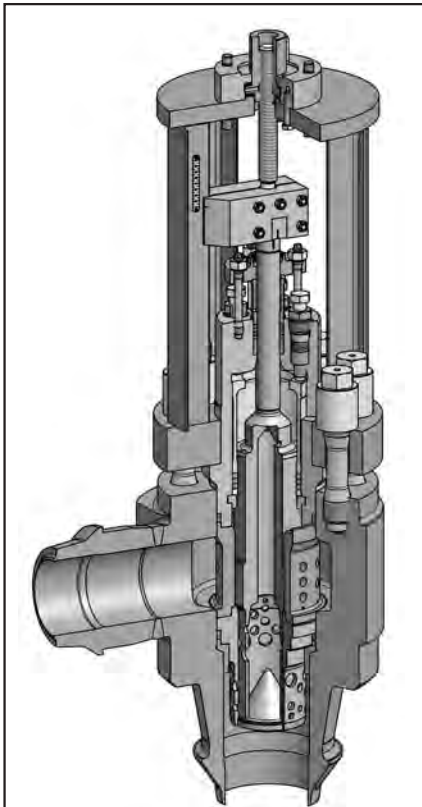

3-stage expansion with balanced pressure for ZK 613

Application

For large flowrates; used as

- Feedwater control valve
- Heating steam valve
- Start-up vessel drain valve

Features

- Excellent sealing and control characteristics

- Extremely wear resistant
- Valve designed on modular assembly principle
- Low sound level
- Easy assembly and inspection of nozzle insert
- Variable valve characteristics (linear and equal-percentage)
- Kv_s range from 28 to 969 m^3/h
- Leakage-free pressure-balanced design

Technical Data

Max. Kv_s values [m^3/h], (linear characteristic), connections, limiting conditions

ZK 610/ZK 613 Angle / Z pattern

Δp (bar)	40/50 1-stage	80/100 2-stage	120/150 3-stage
DN			
100	44 – 98	38 – 54	33 – 47
125	71 – 154	61 – 85	51 – 74
150	112 – 243	95 – 134	81 – 117
200	177 – 385	150 – 212	128 – 185
250	281 – 611	238 – 336	216 – 294
300	446 – 969	378 – 533	322 – 465

ZK 610 Angle / Z pattern

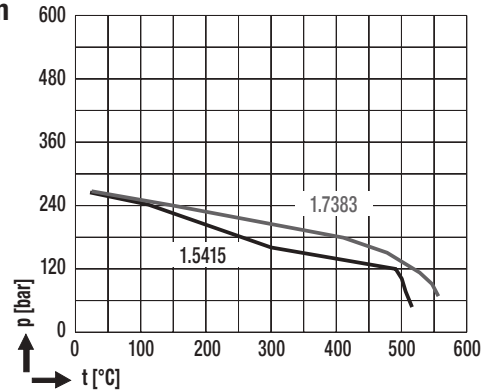

ZK 613 Angle / Z pattern

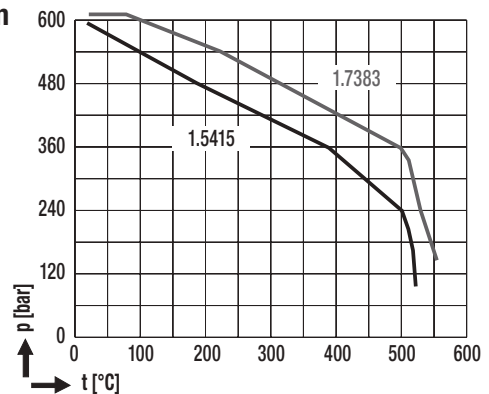

E-mail: info@ de.gestra.com • Fax: (04 21) 35 03-393

Online: www.gestra.com/Service & Support/Questionnaire for preparing offers

Application _____ On / Off
 Fluid _____ Regulation
 Design pressure [barg] _____ Design temperature [°C] _____ PN/CL _____

Operating data

	Load	1	2	3
Loading Flowrate m [t/h]	_____	_____	_____	_____
V [m³/h]	_____	_____	_____	_____
Upstream pressure p1 [bara]	_____	_____	_____	_____
Downstream pressure p2 [bara]	_____	_____	_____	_____
Temperature t1 [°C]	_____	_____	_____	_____

K_{VS}-value from existing valve _____ [m³/h] manufacturer / type _____

Pipeline size To valve inlet _____ Material _____
 To valve outlet _____ Material _____

Valve Data DIN ANSI Characteristic linear equal-percentage
 Body Straight through Angle Z-form Material _____
 Inlet _____ DN FL BW _____ x _____ SW Material _____
 Outlet _____ DN FL BW _____ x _____ SW Material _____
 Material inspection EN 10204-3.1 EN 10204-3.2 Other _____
 Final inspection EN 10204-3.1 EN 10204-3.2 Other _____

Actuator data Handwheel Handwheel convertible to electric rotary actuator
 Electric rotary actuator manufacturer / type _____
 Connection B1-F10 (F14) EN ISO 5210 Other
 Three phase current Other: Voltage / Requency _____ V / _____ Hz: _____ Time [sek.]
 Standard: 2 torque-, 2 position switches, 4-20 mA feedback signal Positioner input signal 4-20 mA

Other _____
 Pneumatic actuator Fail safe Spring to close Spring to open
 Air supply _____ [barg] Handwheel Positioner 4-20 mA Other _____
 3/2-way solenoid valve voltage / frequency _____ V / _____ Hz

Accessories _____

Your details:

Company
Name / job title
Telephone
Fax
E-mail
Date

Electric linear actuator manufacturer / type _____
 Other _____

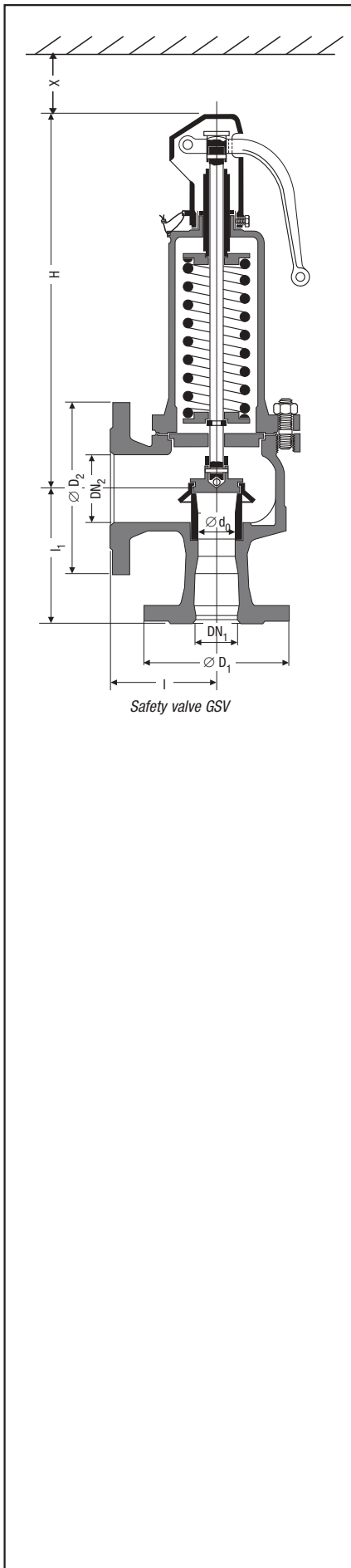

Application

For use with steam, liquids, and non-corrosive gases and vapours.

Dimensions [mm] and Weights [kg]

DN ₁ x DN ₂	20 x 32/40	25 x 40	32 x 50	40 x 65	50 x 80	65 x 100	80 x 125	100 x 150	125 x 200	150 x 250
d ₀	18	23	29	37	46	60	74	92	98	125
l	95	100	110	115	120	140	160	180	200	225
l ₁	85	105	115	140	150	170	195	220	250	285
H ¹⁾	215	233	325	366	413	526	603	660	660	735
H ²⁾	–	234	331	372	419	529	606	663	663	735
X	150	150	200	250	300	350	400	450	450	450
Weight	9	9	12	16	22	32	56	75	85	131

1) 4421, 4425, 4422 2) 4414

Discharge Capacities for Saturated Steam [kg/h]

Set pressure [bar]	DN 20	DN 25	DN 32	DN 40	DN 50	DN 65	DN 80	DN 100	DN 125	DN 150
0.2	86	140	223	363	561	954	1451	2243	2545	4140
0.5	137	224	356	579	895	1523	2316	3581	4062	6609
1.0	199	326	518	843	1302	2215	3370	5209	5910	9616
2.0	318	519	825	1343	2075	3531	5371	8302	9420	15326
3.0	428	699	1111	1808	2794	4754	7232	11178	12683	20635
4.0	534	871	1385	2254	3485	5928	9018	13938	15816	25731
5.0	639	1043	1658	2699	4172	7097	10796	16687	18934	30804
6.0	744	1214	1930	3142	4856	8262	12568	19426	22042	35861
7.0	846	1381	2196	2574	5525	9399	14297	22098	25074	40794
8.0	950	1551	2466	4014	6205	10556	16057	24818	26161	45816
9.0	1054	1721	2736	4454	6884	11712	17815	27535	31244	50831
10.0	1158	1891	3006	4893	7562	12866	19571	30250	34324	55842
12.0	1366	2230	3545	5770	8919	15174	23081	35675	40480	65858
14.0	1569	2562	4073	6629	10247	17433	26518	40987	46507	75664
16.0	1776	2900	4610	7505	11600	19735	30020	46400	52650	85657
18.0	1984	3239	5149	8382	12955	22041	33526	51820	58800	95663
20.0	2191	3578	5688	9260	14312	24350	37039	57249	64960	105685
22.0	2393	3907	6212	10111	15629	26590	40446	62515	70935	115407
24.0	2601	4247	6752	10991	16988	29303	43964	67953	77106	125445
26.0	2810	4588	7294	11873	18351	31222	47491	73405	83292	–
28.0	3019	4930	7837	12757	19718	33547	51029	78873	89496	–
30.0	3229	5272	8382	13644	21089	35880	54577	84358	–	–
32.0	3440	5616	8929	14534	22465	38220	58137	89860	–	–

Calculation according to DIN 3320 and AD Bulletin A2, TRD 421.

For discharge capacities for other set pressure ratings or fluids see data sheet.

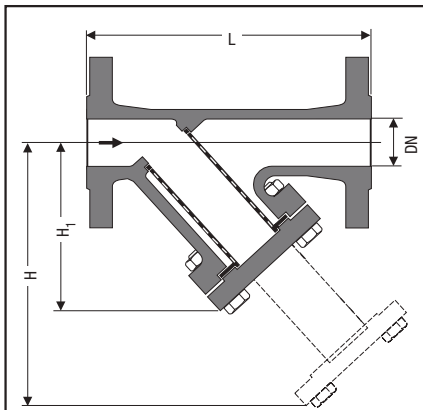

Strainer series
with flanged connections
GSF 11, PN 6, 5.1301
GSF 14, PN 16, 5.1301
GSF 35/36, PN 25/40, GP 240 GH
GSF 46A, PN 16/40, 1.4408
GSF 24, PN 16, 5.3103
GSF 25, PN 25, 5.3103

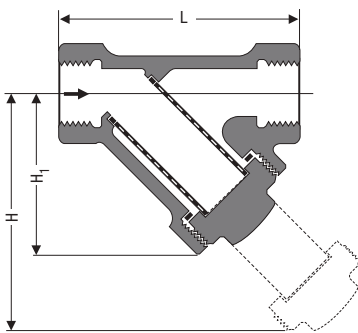

Y-type strainer with
screwed connections series 330
GSF 335, PN 40, CuZn39Pb3

Application

In piping systems upstream of equipment that is sensitive to dirt. For liquids, gases, steam and aggressive fluids.

Dimensions [mm] and Weights [kg] for Y-Type Strainers with Flanged Connections PN 6 - 40

Nominal size		15	20	25	32	40	50	65	80	100	125	150	200	250	300
Overall length	L	130	150	160	180	200	230	290	310	350	400	480	600	730	850
Overall height	GSF 11, 14 H	135	160	180	215	240	250	285	330	395	455	525	650	870	1110
Overall height	GSF 11, 14 H1	90	100	115	135	150	160	180	215	240	280	330	405	540	680
Overall height	GSF 24, 25 H	115	115	135	135	170	190	220	265	340	410	475	580	680	820
Overall height	GSF 24, 25 H1	75	75	90	90	110	120	140	165	220	260	300	360	470	560
Overall height	GSF 35 H												587	718	829
Overall height	GSF 35 H1												380	445	511
Overall height	GSF 36 H	121	121	145	146	200	201	287	292	335	415	485			
Overall height	GSF 36 H1	88	87	100	101	134	135	191	195	224	268	309			
Overall height	GSF 46A H	155	165	180	195	210	225	250	290	340	430	480	590	750	940
Overall height	GSF 46A H1	100	110	120	125	150	165	185	190	200	280	310	390	455	665
Mesh size	GSF 11, 14 mm	1	1	1	1	1	1	1.25	1.25	1.6	1.6	1.6	1.6	1.6	1.6
Mesh size	GSF 24, 25 mm	1.25	1.25	1.25	1.25	1.25	1.25	2	2	2	2	2	2	2	2
Mesh size	GSF 35 mm												2	2	2
Mesh size	GSF 36 mm	1.25	1.25	1.25	1.25	1.25	1.25	1.25	1.25	1.25	2	2	2	2	2
Mesh size	GSF 46A mm	0.5	0.5	0.5	0.5	0.8	0.8	0.8	0.8	0.8	1.0	1.0	1.0	2.1	2.1
Plug	GSF 11, 14 G	3/8	3/8	3/8	3/8	3/8	3/8	1/2	1/2	1/2	1/2	1/2	1/2	1/2	1/2
Plug	GSF 24, 25 G	1/2	1/2	1/2	1/2	1/2	1/2	1/2	1/2	1	1	1	1	1	1
Plug	GSF 35 G												2	2	2
Plug	GSF 36 G	3/8	3/8	3/8	3/8	1/4	1/4	1/4	1/4	1/2	1/2	1/2			
Plug	GSF 46A M	10	10	10	10	12	12	14	14	14	16	16/20 ¹⁾	18	20	22
Weight	GSF 11 kg	2.5	3	4.5	5.5	7	9	13	19	26	38	54	110		
Weight	GSF 14 kg	3	4	5	7	9	12	16	21	30	43	61	121	154	255
Weight	GSF 24 kg	3.5	4	5.5	7	9	12	16	21	28	41	58	121	154	255
Weight	GSF 25 kg	3.5	4	5.5	7	9	12	16	21	32	47	64	133		
Weight	GSF 35 kg												120.6	184.9	269
Weight	GSF 36 kg	3	3.5	4.4	5.8	8.4	11.2	19.4	21.6	32.4	48.2	70			
Weight PN40	GSF 46A kg	5	6	7.5	9	10.5	14	24	28	43	71	99	148	266	499
Weight PN16	GSF 46A kg							20	24	29	53	75	125	239	408

¹⁾ PN 40: M20

Application

In piping systems upstream of equipment that is sensitive to dirt. For liquids, gases, steam and aggressive fluids.

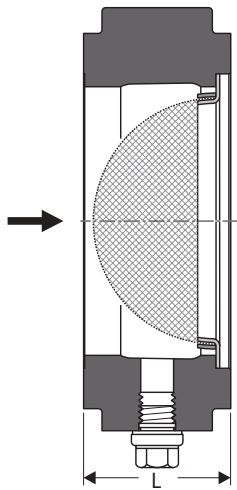

Wafer-type strainers SZ 36A
DN 40 – 100 mm

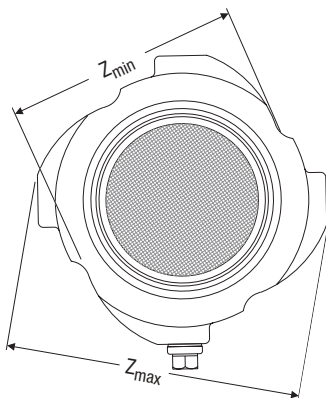

Wafer-type strainers SZ 36A
DN 40 – 100 mm

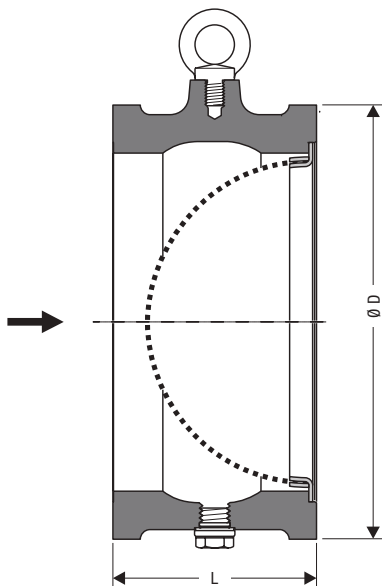

Wafer-type strainers SZ 36A
DN 125 – 200 mm

Features

- Cylindrical body with drain plug
- Robust, hemispherical screen
- Body and strainer made from corrosion-resistant stainless steel
- Minimum pressure loss

Application

In piping systems upstream of equipment that is sensitive to dirt. For liquids, gases, steam and aggressive fluids.

Dimensions and Weights for Wafer-Type Strainers

Types SZ 36A

Nominal size	[mm]	40	50	65	80	100	125	150	200
	[Inch]	1½	2	2½	3	4	5	6	8
Overall length	L	31,5	40	46	50	60	90	106	140
	Ø Z _{min}	83	96	110	128	151	–	–	–
[mm]	Ø Z _{max}	104	118	136	158	186	–	–	–
	Class 125/150	–	–	–	–	–	194	220	275
Ø D	PN 10/16	–	–	–	–	–	194	220	275
	PN 25	–	–	–	–	–	194	226	286
	PN 40	–	–	–	–	–	194	226	293
	Class 300	–	–	–	–	–	216	251	308
	Weight	[kg]	1	1.6	2.1	2.9	4.7	10	14

Pressure/Temperature Ratings *)

Type	PN/Class	Material		Pressure / temperature p / T [bar] / [°C]		
		EN	ASTM			
SZ 36A	PN 40 / Class 300	1.4408	A351 CF8M	49.6 / –200	35.7 / 200	24.9 / 550

*) For more detailed pressure/temperature specifications as a function of the end connection refer to the data sheet.

Design

DN	40 – 100	125 – 200	optional 40 – 200
	Body with centering cams suitable for sandwiching between flanges PN 6-40 and 100 class 150 / 300. Standard strainer	Cylindrical body Standard strainer	Fine screen
Mesh size	1.25 mm	1.6 mm	0.25 mm

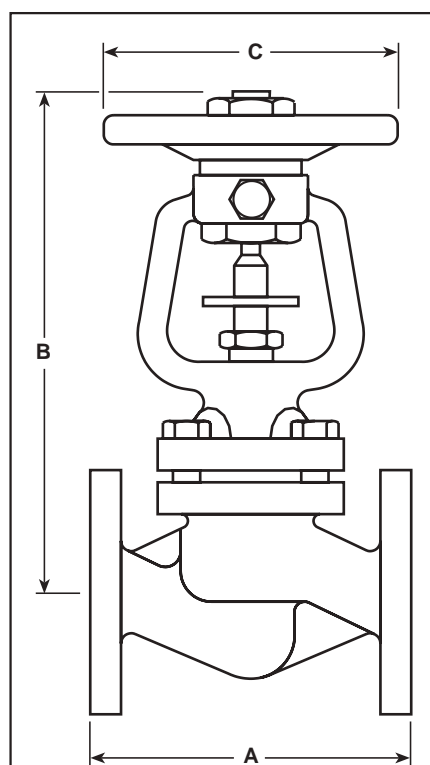

Bellows-sealed stop valve GAV 6xF with safety stuffing box

Description

Straight-through **bellows-sealed** stop valve with flanges to EN 1092. The valve is designed for shutting off and throttling neutral gases, vapours and liquids in all sectors of industry.

Material

Type	DN	Pressure rating	EN	ASTM*)
GAV 63F	15 – 200	PN 16, JIS/KS 10K	GJL-250	A48-40B
GAV 64F	15 – 250	PN 16	GJS-400-18-LT	A536-60-40-18
GAV 65F	15 – 250	PN 25	GJS-400-18-LT	A536-60-40-18
GAV 66F	15 – 200	PN 25, PN 40, Class 150, Class 300, JIS/KS 20K	1.0619	A216WCB
GAV 66AF	15 – 100	PN 40	1.4408	A351CF8M

*) Observe different physical and chemical properties to DIN material.

Specification

Type	Pressure rating	PMA	TMA
GAV 63F	PN 16	16.0 bar / 120°C	300°C / 9.6 bar
	JIS/KS 10K	14.0 bar / 120°C	220°C / 10.0 bar
GAV 64F	PN 16	16.0 bar / 120°C	350°C / 11.2 bar
GAV 65F	PN 25	25.0 bar / 120°C	350°C / 17.5 bar
GAV 66F	PN 25 ¹⁾	25.0 bar / 50°C	400°C / 14.8 bar
	PN 40 ²⁾	40.0 bar / 50°C	400°C / 23.8 bar
	Class 150	19.6 bar / 38°C	425°C / 5.5 bar
	Class 300	51.1 bar / 38°C	425°C / 28.8 bar
	JIS/KS 20K	34.0 bar / 120°C	425°C / 20.0 bar

¹⁾ DN 200 ²⁾ DN 15 – 150

Dimensions [mm]

	DN	15	20	25	32	40	50	65	80	100	125	150	200	250
A	PN	130	150	160	180	200	230	290	310	350	400	480	600	730
	JIS/KS 10K	133	153	163	183	203	229	293	309	349	395	479	592	–
	JIS/KS 20K	152	178	200	–	224	259	–	304	340	–	428	537	–
	Class 150	108	117	127	–	165	203	–	241	292	–	–	–	–
	Class 300	152	178	203	–	229	267	–	317	356	–	445	559	–
B		205	205	217	217	243	243	263	287	383	416	450	622	763
C		125	125	125	125	200	200	200	200	315	315	315	500	500

Weights [kg]

	DN	15	20	25	32	40	50	65	80	100	125	150	200	250
GAV 63F, GAV 64F, GAV 65F		4	4	5	7	10	12	16	21	36	52	75	145	180
GAV 66F	PN	4	5	6	8	11	14	19	26	44	64	88	180	–
GAV 66F	Class 150	5	6	8	–	10	12	–	25	41	–	–	–	–
GAV 66F	Class 300 / JIS/KS 20K	6	7	9	–	11	15	–	29	49	–	94	193	–
GAV 66AF		4	5	6	8	11	14	19	26	44	–	–	–	–

If the following differential pressures are exceeded in valves with standard plug, a pressure balance plug is required.

Pressure balance plug

	DN	65	80	100	125	150	200	250	300
GAV 63F, GAV 66F	Δp bar	–	–	–	–	–	10	–	6

K_{vs} Values [m³/h] of valves with throttling plug

	DN	15	20	25	32	40	50	65	80	100	125	150	200	250
GAV 6xF,		5.4	6.6	11.9	19.6	29.3	47.2	74.6	101.6	186	259	369	522	827



Description

Straight-through **stuffing-box sealed** stop valve with flanges to EN 1092 or butt-weld ends (BW) to EN 12627. The valve is designed for shutting off and throttling neutral gases, vapours and liquids in all sectors of industry.

Material

Type	DN	PN	EN	ASTM*)
GAV 126	50 – 200	63	GP240GH+N	A216WCB
GAV 130	50 – 200	100	GP240GH+N	A216WCB
GAV 136	15 – 25	160	P250GH	A105
GAV 136	32 – 200	160	GP240GH+N	A216WCB
GAV 136SE	15 – 50	160	16MO3	A182F1
GAV 136SE	65 – 200	160	GP240GH+N	A216WCB
Up to 550 °C				
GAV 126	50 – 200	63	G17CrMo5-5	A217WC6
GAV 130	50 – 200	100	G17CrMo5-5	A217WC6
GAV 136	15 – 25	160	13CrMo4-5	A182F11
GAV 136	50 – 200	160	G17CrMo5-5	A217WC6
GAV 136SE	15 – 50	160	13CrMo4-5	A182F11
GAV 136SE	65 – 200	160	G17CrMo5-5	A217WC6

*) ASTM nearest equivalent is stated for guidance only. Physical and chemical properties comply with EN.

Specification

Type	PN	Material	Service pressure p / Inlet temperature T (barg/°C)						
			20	300	400	450	500	530	550
GAV 126	63	GP240GH+N	63	44	38	21	–	–	–
GAV 130	100	GP240GH+N	100	69	60	33	–	–	–
GAV 136, GAV 136SE	160	P250GH / GP240GH+N	160	110	95	53	–	–	–
GAV 136SE	160	16MO3	160	137	120	110	71	36	–
GAV 126	63	G17Cro5-5	63	63	57	53	41	23	15
GAV 130	100	G17Cro5-5	100	100	90	84	65	37	23
GAV 136, GAV 136SE	160	13CrMo4-5 / G17Cro5-5	160	160	144	135	104	59	37

Dimensions [mm]

PN 63 – 160 flanged ends	DN	15	20	25	32	40	50	65	80	100	125	150	200
Overall length	L ₁	210	230	230	260	260	300	340	380	430	500	550	650
GAV 126, GAV 130, GAV 136	H ₁	230	230	230	310	310	315	415	500	550	620	625	855
PN 63 – 160 butt-weld ends	DN	15	20	25	32	40	50	65	80	100	125	150	200
Overall length	L ₁	150	150	160	180	210	250	420	460	510	600	650	750
GAV 136SE	H ₁	230	230	230	310	310	315	415	500	550	620	625	855

Weights [kg]

PN 63 – 160 flanged ends	DN	15	20	25	32	40	50	65	80	100	125	150	200
GAV 126		–	–	–	–	–	25	40	55	85	125	150	260
GAV 130		–	–	–	–	–	26	45	58	88	135	170	285
GAV 136		9.5	11	12.5	16.5	20.5	26	45	60	90	135	175	320
PN 63 – 160 butt-weld ends	DN	15	20	25	32	40	50	65	80	100	125	150	200
GAV 136SE		6.5	7.5	8.5	11	13.5	17	30	45	72	110	165	215

If the following differential pressures are exceeded in valves with standard plug, a pressure balance plug is required.

Pressure balance plug

	DN	65	80	100	125	150	200
GAV 126, GAV 130, GAV 136, GAV 136SE		110	70	44	33	21	14

K_{vs} Values [m³/h]

	DN	15	20	25	32	40	50	65	80	100	125	150	200
GAV 126, GAV 130, GAV 136	PN 63, 100, 160	2.7	4	5	16	17	26	50	80	125	200	280	580

As Europe's largest provider of boiler equipment, GESTRA meets all the needs of today's market: a broad spectrum of products, faster time-to-market for new products, more performance for less money and customized solutions and services. This unique market position is based on extensive experience acquired over more than 50 years in the design and manufacture of high-quality safety-oriented control equipment. To compete in a truly global market, GESTRA is continuing to consolidate the domestic market and, simultaneously, stepping up its efforts to deepen international activities outside Europe in order to optimize and extend its network of sales and marketing organizations all over the world. GESTRA technology is tailored to your needs, offering you the right solution – be it conventional or bus-based – for your land or marine applications. Hight-tech for enhanced safety and reliability!

Industrial Electronics



	Page
Overview	86
The benefits of SPECTOR <i>connect</i>	87
GESTRA Steam boiler equipment with CONNECT technology	88
The benefits of SPECTOR <i>module</i> / SPECTOR <i>module</i> Touch.....	89
GESTRA Steam boiler installation SPECTOR <i>module</i>	90
GESTRA Condensate monitoring.....	91
How to read type codes	92 – 93
GESTRA Boiler equipment.....	94 – 95
Type approval nos. at a glance.....	96
Equipment for steam & hot water boilers	97
Level control, monitoring and limitation.....	98
Basics of SPECTOR <i>connect</i>	99 – 100
Level limitation (low and high level alarms) SPECTOR <i>connect</i>	101 – 103
Level control SPECTOR <i>connect</i>	104 – 105
Control & visual display system SPECTOR <i>control</i>	106 – 107
Basics of SPECTOR <i>module</i>	109
Self-monitoring low/high-level alarms SPECTOR <i>module</i>	110 – 111
High level limiters SPECTOR <i>module</i>	112 – 113
Modulating level control SPECTOR <i>module</i>	114 – 115
Level control SPECTOR <i>compact</i>	116 – 117
Accessories for liquid-level alarms fitted in external level control pots	118 – 119
Level control for very high pressure/temperature ranges.....	120
Level electrodes and controls for marine applications	121 – 122

Safety, reliability, availability and economy have always enjoyed top priority in boiler operation. To an increasing extent, another aspect is being added for the plant operators: process automation and visualization.

To meet these stringent requirements, GESTRA AG has – for more than five decades now – been working exclusively with electrode systems that are low in maintenance and wear; in contrast to other systems, they function entirely without moving parts, which leads to high service lifetimes and very low failure rates.

By now, these GESTRA electrode systems are being applied in many different areas of the energy supply centre. In addition to the boiler equipment itself, these units are also used in condensate tanks, pump-driven return installations, steam regenerators etc. With a low response sensitivity of $> 0.5 \mu\text{S}/\text{cm}$, even operation with demineralization equipment does not pose a problem. In general, the entire energy supply centre is only as effective as its weakest element. Many plant operators, designers and manufacturers are therefore no longer prepared to enter into any compromises in this area.

Nothing is as cost-intensive as a production outage.

Over and above these aspects, the requirements for the equipment of an energy supply centre tend to differ greatly. The requirements can no longer be met with one and the same system, as was perhaps the case only 10 to 15 years ago. The wishes expressed by the customers have always been the driving force behind GESTRA's innovative developments, and this is still the case today.

There is no longer a “one size fits all” system for customer requirements!

Another step forward was taken for the GESTRA equipment components through the introduction of the SPECTOR family, which focuses on meeting the customer's specific needs. The family now consists of SPECTORcompact, SPECTORconnect and SPECTORmodule.

SPECTORcompact

SPECTORcompact comprises systems that facilitate the easy replacement of existing self-acting systems. Measurement values are transferred as standard 4–20 mA signals or can be incorporated into existing controllers via integrated volt-free relay contacts without any need for additional electronic control units. If necessary, controllers are of course also available for implementing the entire controlled systems.

SPECTORconnect

SPECTORconnect offers easy integration into automation concepts by means of remote data transmission and parameter setting.

Thanks to many technical innovations, the design, erection and commissioning of plants is simplified considerably. A tried and tested system that meets the requirements made on boiler equipment today and in the future. Now, with SPECTORconnect, a large amount of process-relevant data can be transmitted for the first time. Further information is given in the separate brochure “Equipment for Energy Supply Centres – SPECTORconnect”

SPECTORmodule

The SPECTORmodule line represents a systematic advancement of the proven GESTRA technology. Using the most modern electronic components and constituting the state of the art, these systems were designed with a focus on ease of handling, reducing the installation expense, and providing cost-effective solutions.

New units were developed as demand-oriented solutions for boiler automation. The scope of the parameterization was limited to the most essential functions to ensure intuitive operating of the controllers.

Depending on the task at hand, the customer can choose between the system variants SPECTORmodule and SPECTORmodule Touch.

SPECTORmodule concentrates on the key functions, and the parameters are set by means of a rotary pushbutton.

SPECTORmodule Touch

The SPECTORmodule Touch version focuses on the essentials: the main functions and a clear, intuitive user interface.

With this series, the controller was separated from the operating unit, which means that the laborious wiring for sensors, feedback, limits, valve actuation etc in the control cabinet door is no longer required.

Universal controllers generally entail a large number of parameter settings, making the operating workflow and the setting of parameters more difficult.

In the development of the SPECTORmodule Touch series, clear and easily understandable operating was a top priority.

Thanks to the intuitive user interface, the operator can enter the parameters rapidly and reliably. The colour touch display leads directly to the parameterization level. A virtual numerical keypad is shown, so that values can be changed or functions selected.

Care was taken to ensure that the various controllers always have the same clear, uniform operating structure.

To give customers and plant operators greater convenience, we design our systems with a focus on

- optimized system interfaces
- minimized maintenance

GESTRA – always the right solution!

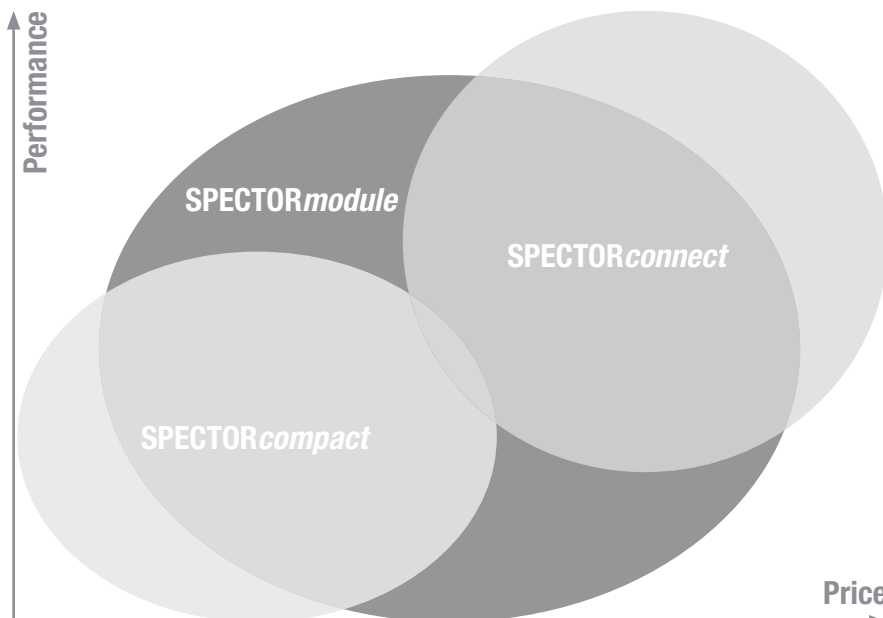

GESTRA SPECTOR*connect*

More safety, more efficiency, more steam

Intelligent, global monitoring

An extensive and adjustable data connection enables global system monitoring. Clear graphics, historic data and alarms provide clear information about the steam generation process.

Always state of the art

SPECTOR*connect* satisfies the requirements of the latest standards for safe steam boiler operation.

One unit, several functions

All the important functions necessary for efficient system operation have been integrated in a single unit, saving installation time and cutting costs.

Reliable service interval monitoring

The plant operator is informed when components require a service or the system is outside its normal operating range.

Constantly low energy consumption, reduced process costs

Temperature-compensated measurement and control of conductivity in the steam drum itself reduces the blowdown volume to an absolute minimum.

Market and usage

The SPECTOR*connect* system is used in steam and hot water boiler systems to TRD 604, EN 12952 and EN 12953.

Development has consistently focused on safety, enabling a SIL 2/3 rating to be achieved for conductivity limiting as well.

The URB 60 display unit functions as a data interface and supports various data protocols.

The pressure and temperature ratings are up to 183 bar and 357 °C.

Benefits at a glance

1. No risk of overheating:

- Patented thermal barrier in cylindrical body above electrode flange
- Electronic temperature protection in the terminal box
- Patented connection arrangement
- Minimization of thermal effects

2. Easy installation and maintenance:

- Freely accessible connecting terminals at the control units
- Large terminal box makes for easy installation

3. Increased safety:

- Active cable monitoring with more than twice the previous maximum cable length
- Easy to integrate into visual display and automation systems



Less is more!

From little acorns big oaks grow. With SPECTOR*connect* by GESTRA, a new era has begun in the measurement and control of boiler systems:

- Less cabling (preconfigured cable connection)
- Less installation work
- Less space needed in control cabinets
- Fewer control units
- Less wear and tear
- Less maintenance
- Fewer production outages
- Lower costs
- More control
- Better process overview
- Higher availability
- Enhanced reliability
- Greater plant efficiency
- Better utilization of energy
- Longer plant operation times

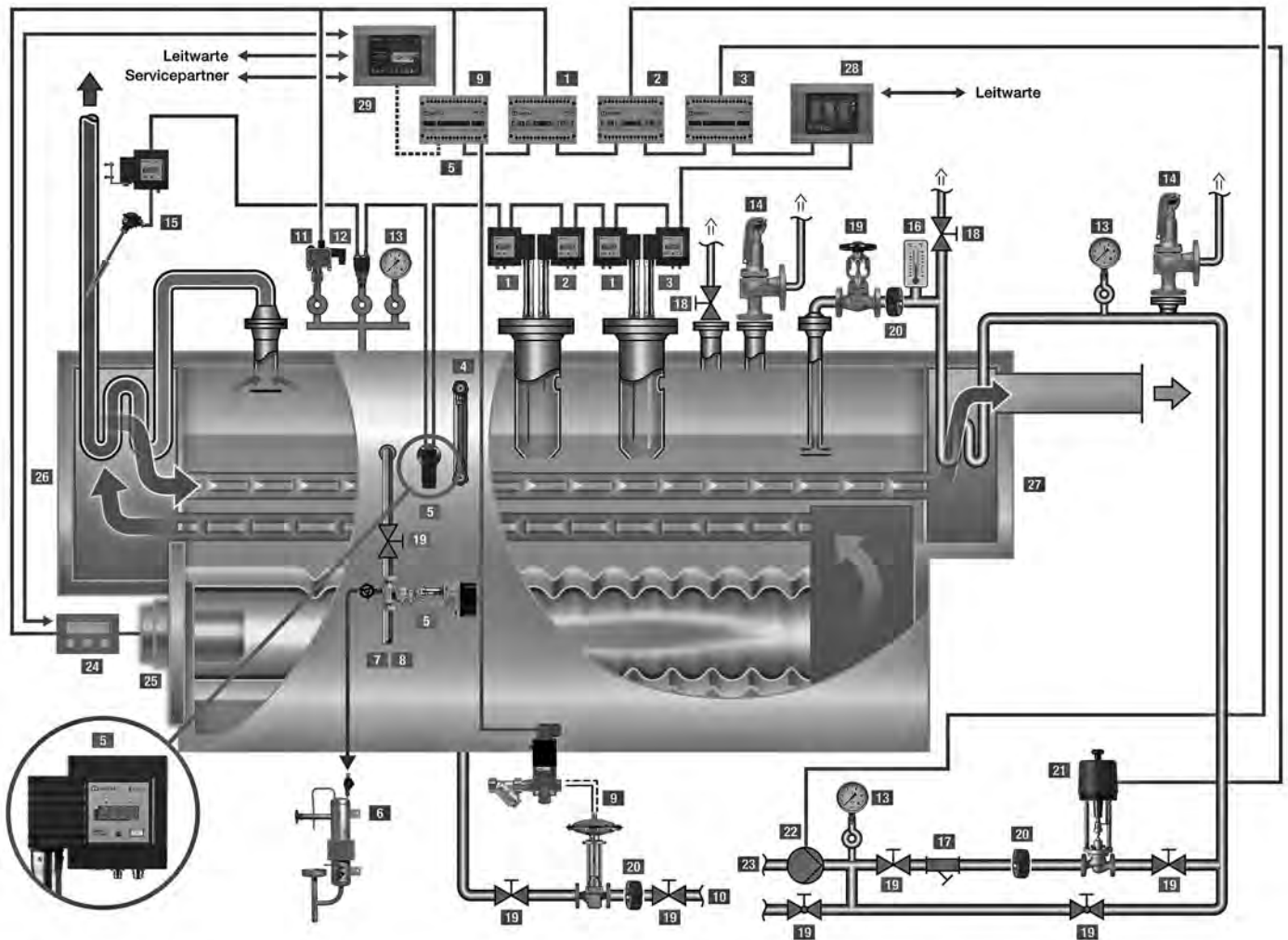

GESTRA Steam Boiler Equipment SPECTORconnect

- | | | |
|--|---|---|
| <p>1 “SMART” water level limiting system: level electrode with periodic self-testing NRG16-60, level switch URS 60</p> <p>2 “SMART” high level limiting system with periodic self-testing: level electrode NRG 16-61, level switch URS 61</p> <p>3 Continuous water level control system: level electrode NRG 26-60, level controller NRR 2-60</p> <p>4 Direct water level indicator</p> <p>5 Conductivity control / continuous and intermittent boiler blowdown: conductivity electrode LRG 16-61, continuous blowdown controller LRR 1-60, continuous blowdown valve BAE 46</p> <p>6 Sample cooler PK for safe and precise manual sampling (VRM)</p> <p>7 Flash vessel for heat recovery</p> <p>8 Blowdown cooler for heat recovery</p> <p>9 Intermittent blowdown valve MPA, three-way pilot valve</p> | <p>10 Blowdown receiver</p> <p>11 Pressure limiter</p> <p>12 Pressure controller/transmitter</p> <p>13 Pressure gauge</p> <p>14 Safety valve</p> <p>15 Safety temperature limiter for superheater, resistance thermometer TRG 5-65, temperature transmitter TRV 5-60</p> <p>16 Thermometer</p> <p>17 Strainer GSF</p> <p>18 Vent valve</p> <p>19 Shut-off and bypass valve GAV</p> <p>20 Non-return valve RK 86</p> <p>21 Electrically/pneumatically operated control valve GCV</p> <p>22 Feedwater pump</p> | <p>23 Make-up water monitoring: full demineralization via conductivity monitoring LRG 16-9/LRS 1-7, partly demineralization via monitoring residual hardness</p> <p>24 Burner control with MODbus RTU interface</p> <p>25 Burner</p> <p>26 Superheater</p> <p>27 Economiser</p> <p>28 Operating unit URB 60</p> <p>29 SPECTORcontrol is a universal controller and operating unit for process data acquisition (with CAN, MODbus, Ethernet, OPC and optional Profibus interface) and can be used instead of URB 60</p> |
|--|---|---|

SPECTOR*module*

- Compact design
- Easily accessible connection terminals
- Supply voltage 24 VDC, i. e. independent of national supply voltages
- Supply via reliable networks possible without additional components (inverters)
- Intuitive operating using rotary pushbutton
- Indication by 7-segment digital display

SPECTOR*module* Touch

- Separation of power components and operating level, i. e. no elaborate wiring needed in the control cabinet door.
- Use of a colour touch display for intuitive, clear operating that is language-neutral
 - Level:**
 - ▶ Intuitive operating through touch display incl. visualization of the actual, set and control values
 - ▶ Trend plot
 - ▶ PI control response
 - Optional: ◆ 3-element control
 - ▶ Actual-value output 4–20 mA
 - Conductivity:**
 - ▶ Intuitive operating through touch display incl. visualization of the actual, set and control values
 - ▶ Type approval as per “WÜ 100” (VdTÜV bulletin on water monitoring facilities)
 - ▶ Integrated purging pulse
 - ▶ Integrated program-controlled intermittent blowdown
 - ▶ Interlocking input to prevent simultaneous operation of two or more intermittent blowdown valves at one blowdown receiver

The 24 VDC version offers the following advantages:

- Uniform DC power supply for sensors and electronic control units alike
- Through that, improved EMC control
- Independence from different national mains voltages
- Avoidance of the need for uncommon (and costly) device variants
- Easily adaptable operation with reliable voltage supplies

Only 230 VAC available as the supply voltage? No problem, we have tailor-made power supply units to bridge the gap.

Total power consumption of connected equipment

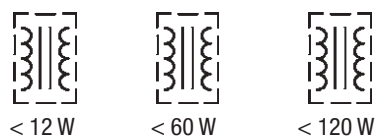

The total power output of the connected equipment determines which power supply unit is used and/or whether the existing 24 V DC supply system can accept the additional load.

The 24 V DC versions of the sensing units LRGT and NRGT have established themselves and facilitate a standardized voltage supply arrangement.

Sample calculation for a 24 V power supply unit:

Unit	Power	Qty	Total consumption
NRS 1-50, 1E/2E	7 W	1	7 W
NRS 1-51	7 W	1	7 W
NRGT 26-1	5 W	1	5 W
NRR 2-52 with	5 W	1	5 W
URB 50	8 W	1	8 W
LRGT 16-1	3 W	1	3 W
LRR 1-52 with	5 W	1	5 W
URB 50	8 W	1	8 W
MV 340c	8 W	1	8 W
			Sum 56 W

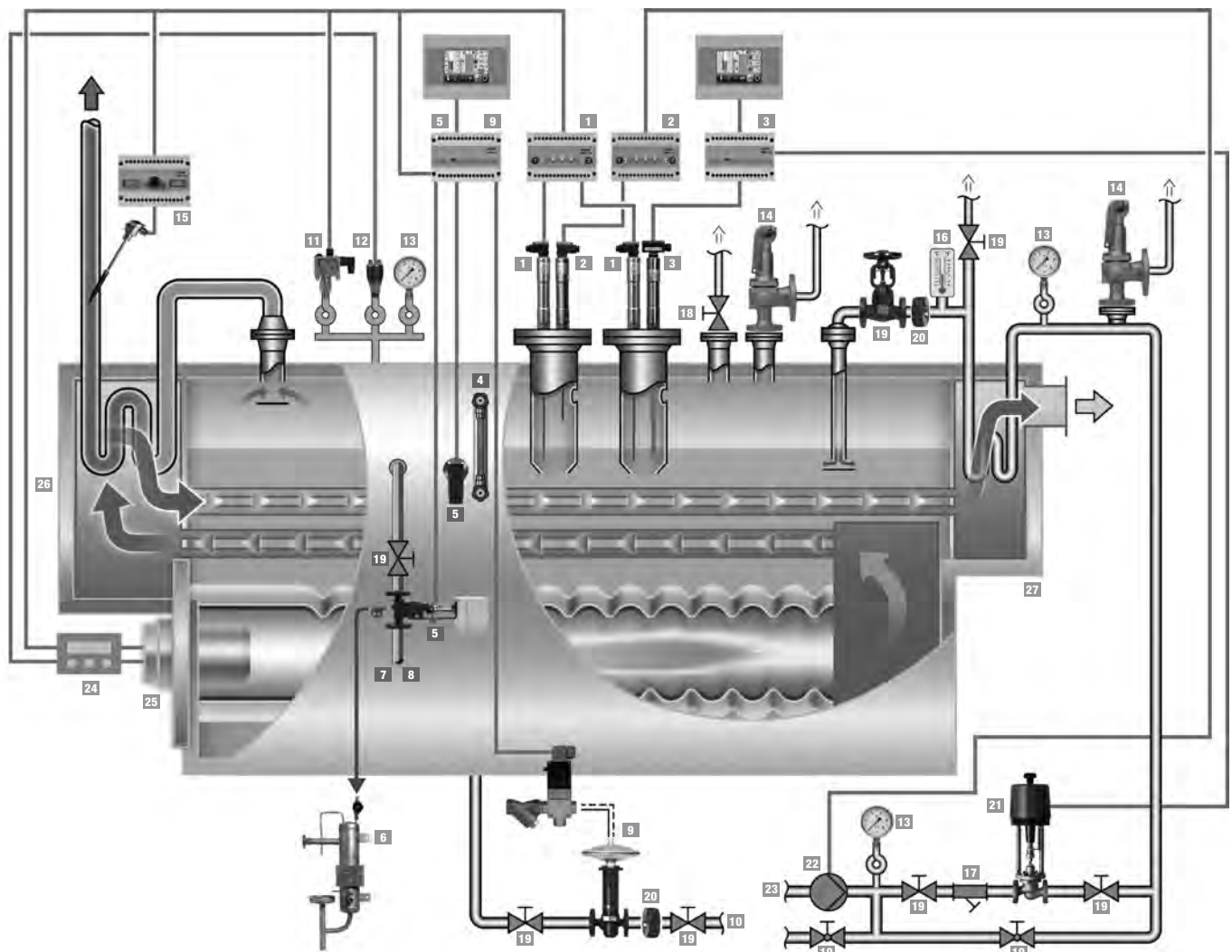

GESTRA Steam Boiler Equipment SPECTORmodule

- | | | |
|--|---|---|
| <p>1 “SMART” level electrode NRG 16-50 for low-water level limiting, level switch NRS 1-50, SIL 3</p> <p>2 Separate “SMART” level electrode NRG 16-51 for high level alarm, level switch NRS 1-51, SIL 3</p> <p>3 Water level control with high level alarm, remote indication of water level: level electrode NRG 26-21, level controller NRR 2-52 and control valve V 701</p> <p>4 Direct water level indicator</p> <p>5 Conductivity control & indication, conductivity limit switch and continuous blowdown control: conductivity electrode LRGT 16-2, continuous blowdown controller LRR 1-53, continuous blowdown valve BAE</p> <p>6 Sample cooler</p> | <p>7 Flash vessel</p> <p>8 Blowdown cooler</p> <p>9 Automatic intermittent blowdown: intermittent blowdown valve MPA, pilot valve</p> <p>10 Blowdown receiver</p> <p>11 Pressure limiter DSF</p> <p>12 Pressure transducer DRT</p> <p>13 Pressure indication</p> <p>14 Safety valve GSV</p> <p>15 Safety temperature monitor/limiter, resistance thermometer TRG, temperature switch TRS 5-50, SIL 3</p> <p>16 Thermometer</p> | <p>17 Strainer</p> <p>18 Vent valve</p> <p>19 Shut-off valve and bypass valve</p> <p>20 Non-return valve</p> <p>21 Electrically/pneumatically operated control valve GCV</p> <p>22 Feedwater pump</p> <p>23 Feedwater/condensate monitoring</p> <p>24 Burner control</p> <p>25 Burner</p> <p>26 Superheater</p> <p>27 Economiser</p> |
|--|---|---|

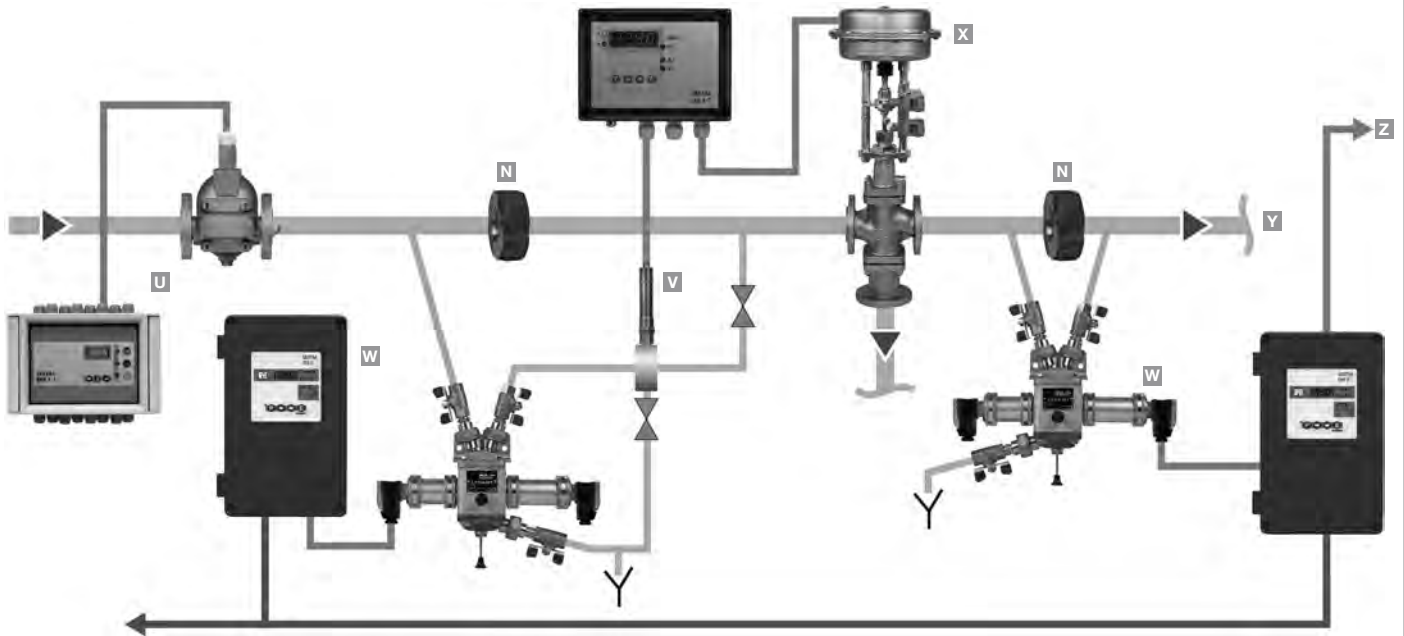

Steam and Condensate System

- N** Non-return valve RK 86 with special spring 20 mbar
- U** Steam trap with trap monitoring equipment, test chamber VKE, electrode NRG 16-19, test station NRA 1-3 for up to 16 steam traps
- V** Contamination detectors (ingress of acids, alkalis, etc.): Conductivity electrode LRG 16-9, Conductivity switch LRS 1-7a
- W** Monitoring for the ingress of foreign substances such as oil, grease etc.: Oil and turbidity detector OR 52/5
- X** Pneumatic three-way control valve for the discharge of contaminated condensate
- Y** Condensate receiver tank
- Z** Safety circuit

GESTRA Type Designations for Boiler Controls

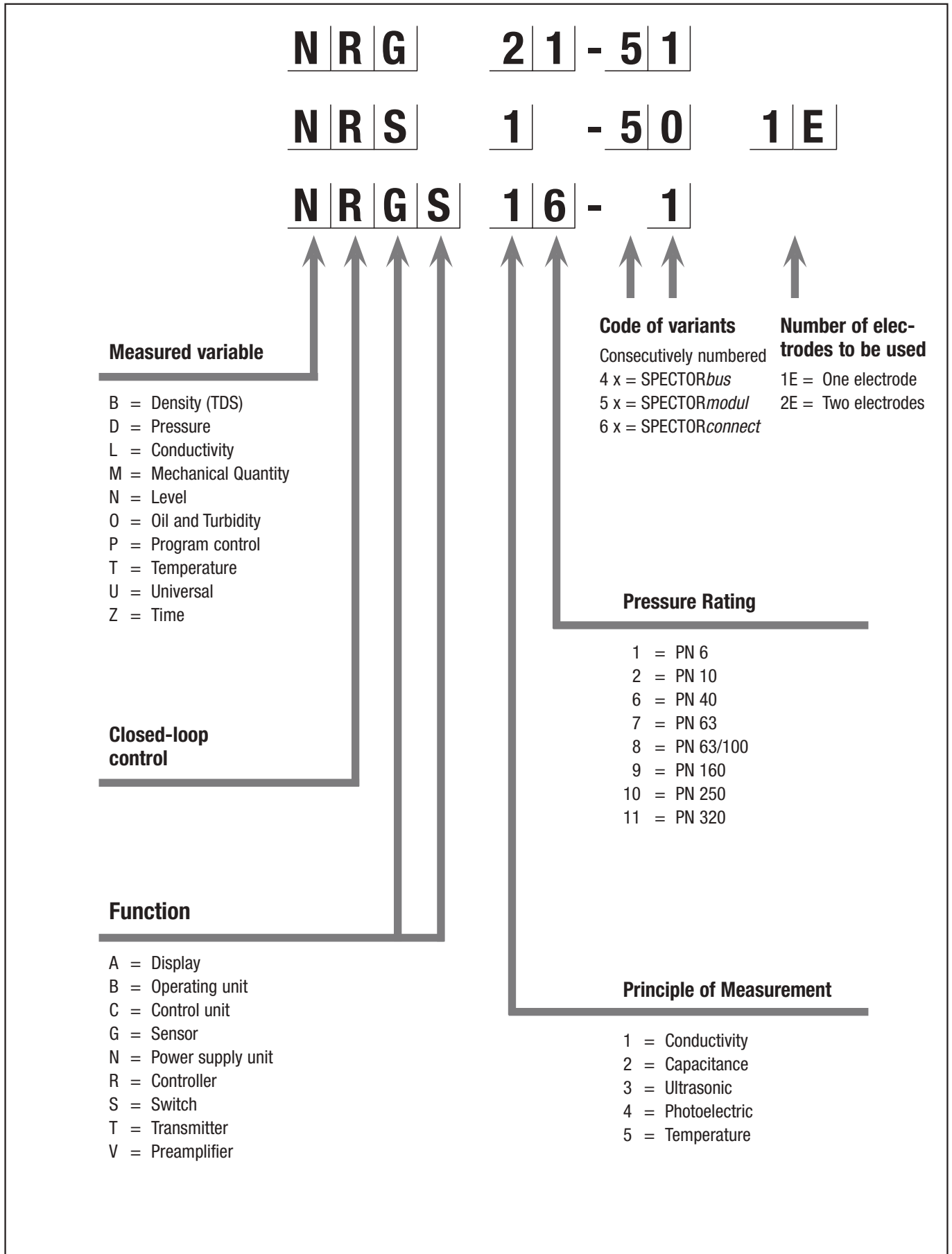

GESTRA Type Designations for Boiler Controls

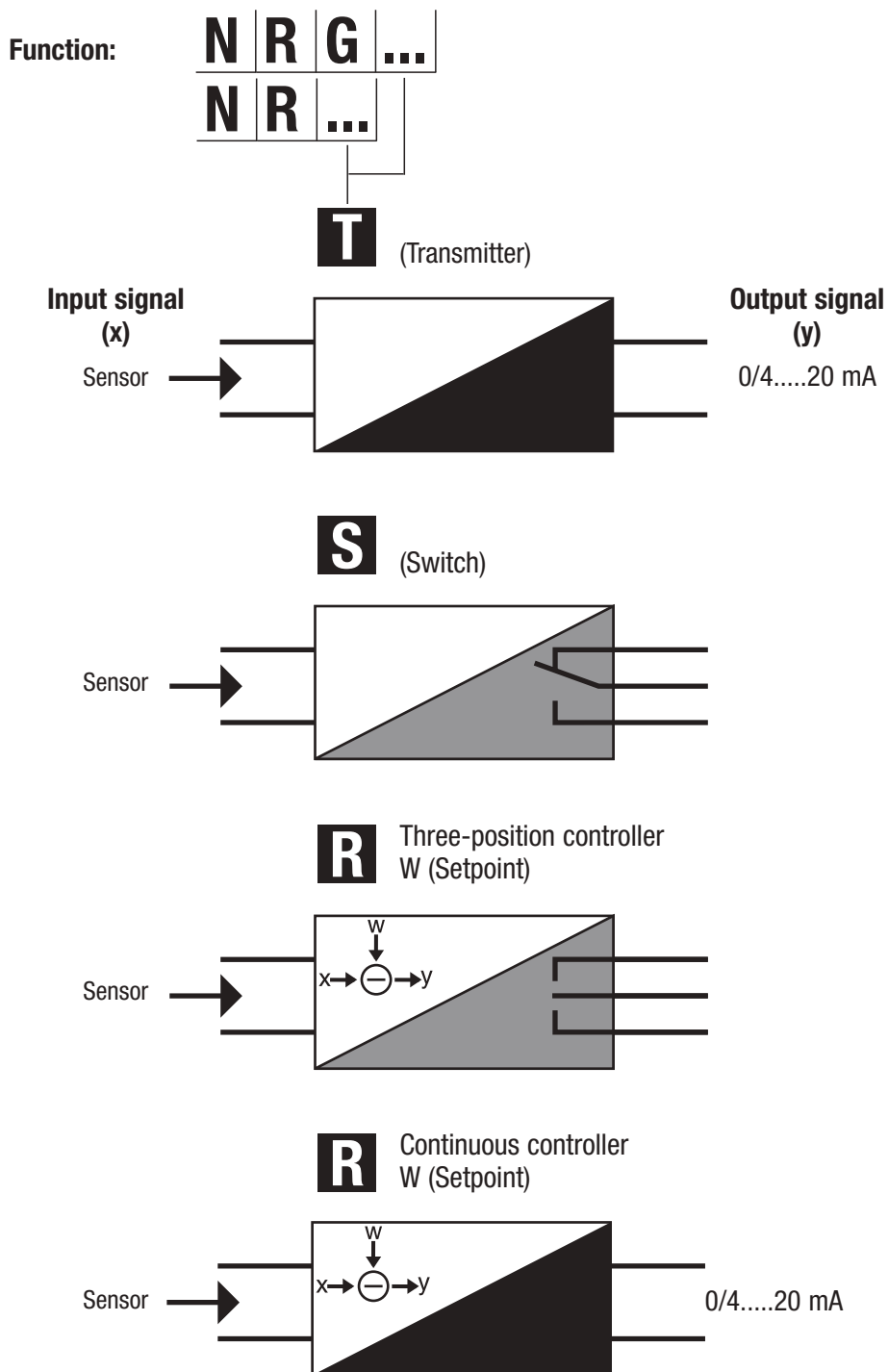

B

Function	Required	Recommended	Section	Equipment type	Type approval no.
		SPECTOR...			
Water level limiters, two	yes	<i>bus</i>	HPSB 4.3 5.6.1	NRG 16-40 / NRS 1-40 "SMART" equipment ("high integrity design") with periodic self-testing routine (loss of redundancy, relay contacts)	EG BAF-MUC-12-05-103881-002 TÜV SWB/SHWS XX-403 SIL 2
		<i>modul</i>	HPHWI 6.5.1	NRG 16-50 / NRS 1-50 "SMART" equipment ("high integrity design") with periodic self-testing routine (loss of redundancy) and positive-action safety relay	Type examination to PED TÜV SWB XX-422 SIL 3
Water level limiter / High level alarm in BUS system	yes	<i>bus</i>	HPSB 4.3 5.6.1 5.5.2	NRG 16-40 / NRS 1-40 NRG 16-41 / NRS 1-41 "SMART" equipment ("high integrity design") with periodic self-testing routine (loss of redundancy, relay contacts)	EG BAF-MUC-12-05-103881-002 TÜV SWB/SHWS XX-403 SIL 2
Water level limiter / High level alarm / Temperature limiter in BUS system	yes	<i>connect</i>	HPSB 4.3 5.6.1 5.5.2 5.6.3	NRG 1.-60 / NRG 1.-61.1 / URS60 / URS61 TRG 5-6. / TRV 5-60 / LRG 16-60 "SMART" equipment ("high integrity design") with periodic self-testing routine (loss of redundancy, relay contacts)	Water level (conductive): 01 202 641/B-19-0009 Temperature: 01 202 641/B-19-0010 Conductivity: TÜV SWB/HWS/STW(STB)/SWÜL XX-430 / SIL 2/3
Water level limiter with closed loop control and high level alarm	yes	<i>modul</i>	HPSB 4.3 5.6.1 5.5.1 5.5.2	NRG 16-36 / NRS 1-50 / NRS 1-54 "SMART" limiter ("high integrity design") with periodic self-testing routine (loss of redundancy) and positive-action safety relay	Type examination to PED TÜV SWB XX-422 TÜV WR XX-424 (controller)
On-off water level limiter with high level alarm	yes	<i>compact</i>	HPSB 5.5.1	NRGS 16-1 On-off control	TÜV WR XX-388
		<i>modul</i>	5.5.2	NRG 16-52 / NRS 1-54 Fixed switchpoints	TÜV WR/WB XX-424
		<i>modul</i>		NRG. 26-1 / NRS 2-50 / NRS 2-51 Variable switchpoints	TÜV WR XX-425
Continuous water level limiter with high level alarm	yes	<i>compact</i>	HPSB 5.5.1	NRGT 26-1 with continuous monitoring Current output 4...20 mA	TÜV WRS XX-391
		<i>connect</i>	5.5.2	NRG 26-60 / NRR 2-60 / NRR2-61 / URB 60	TÜV WR XX-431
		<i>modul</i>		NRG. 26-1 / NRR 2-50 / NRR 2-51	TÜV WR XX-425
		<i>modul</i>		NRG. 26-1 / NRR 2-52 / NRR 2-53	TÜV WR XX-427
Separate high level alarm		<i>bus</i>	Not required acc. to EN.	NRG 16-41 / NRS 1-41 "SMART" equipment ("high integrity design") with periodic self-testing routine (loss of redundancy, relay contacts)	EG BAF-MUC-12-05-103881-002 TÜV SHWS XX-423 SIL 2
		<i>modul</i>	Required for installations to TRD 72h	NRG 16-51 / NRS 1-51 "SMART" equipment ("high integrity design") with periodic self-testing routine (loss of redundancy) and positive-action safety relay	Type examination to PED TÜV SHWS XX-423 SIL 3
		<i>modul</i>		NRG 16-4 / NRS 1-52 "Conventional design"	TÜV WR/WB XX-424
Safety temperature limiter	yes	<i>modul</i>	HPHWI 6.5.2.3	TRG 5-6. / TRS 5-50 "SMART" equipment ("high integrity design") with periodic self-testing routine (loss of redundancy) and positive-action safety relay	EG Z-IS-TAF-MUC-12-10-103881-009 DIN CERTO STW/STB 1230 SIL 3

HDD = High-pressure steam boiler, HDHW = High-pressure hot water installation

Function	Required	Recommended	Section	Equipment type	Type approval no.
		SPECTOR...			
Raising the return temperature	yes	<i>connect</i>	HPHWI 6.1.4 6.5.2.3	TRG5-6. / URS60 / URB	TÜV SWB/HWS/STW(STB)/SWÜL XX-430
		<i>modul</i>			
Safety pressure limiter	yes		HPSB 4.3 5.6.2 HPHWI 6.5.2.1	DSF .F 001 "SMART" equipment	www.tuev.com 0000006024
Conductivity limit detector for boiler water *)	yes	<i>modul</i>	HPSB 4.8.1	LRG 16-4 / LRS 1-50 LRG 16-9	Z-IS-TAF- MUC-19-05-2652073-24105219 TÜV WÜL XX-018
				LRG 16-4 / LRG 16-9 / LRGT 1.-. / LRR 1-50 / LRR 1-51 / LRR 1-52 / LRR 1-53	TÜV WÜL XX-017 Z-IS-TAF- MUC-19-05-2652073-24102846
		<i>connect</i>		LRG 1.-6. / URS 6. / URB 60	01 202 641-B-19-0013 TÜV.SWB/HWS/STW(STB)/SWÜL.XX-430
Automatic continuous boiler blowdown with limit signaling *)	yes	<i>connect</i>	HPSB 4.8.1	LRG 16-60 / LRG 16-61 / LRR 1-60 / URB 60 / LRG 17-60 / SPECTOR <i>control</i>	TÜV WÜL XX-020
		<i>modul</i>		LRG 16-4 / TRG 5-6. / LRR 1-52 LRGT 1.-. / LRR 1-53	Z-IS-TAF- MUC-19-05-2652073-24102846 TÜV WÜL XX-017
				LRG 16-4 / TRG 5-6. / LRR 1-50 LRGT 1.-. / LRR 1-51	Z-IS-TAF- MUC-19-05-2652073-24102846 TÜV WÜL XX-017
Automatic intermittent boiler blowdown	yes	<i>compact</i>	HPSB 4.6	TA 7	
		<i>connect</i>		LRR 1-60	
		<i>modul</i>		LRR 1-52 / LRR 1-53	
Conductivity limit detector for salt-free make-up water *)		<i>modul</i>	HPSB 4.8.4 HPHWI 4.8.4	LRG 16-4 / LRG 16-9 / LRS 1-50 / LRG 16-9 / LRS 1-7	TÜV WÜL XX-018 TÜV WÜL XX-014
Detecting residual hardness of saline feedwater *)					
Condensate monitoring for ingress of oil, fat, grease, acids, alkalis etc.	yes	<i>modul</i>	HPSB 4.8.2 HPHWI 4.8.3	OR 52-5 / OR 52-6 LRG 16-9 / LRS 1-7 LRG 16-4 / LRS 1-50	TÜV WÜF XX-009 TÜV WÜL XX-014 TÜV WÜL XX-018

*) Limits and reference values acc. to EN 12952-12 and EN 12953-10

HPSB = High-pressure steam boiler

HPHWI = High-pressure hot water installation

Type Approval Number Code

T | **Ü** | **V** | **S** | **W** | **B** | **0** | **2** | **4** | **0** | **3** |

Safety

Measured quantity

W = Water

T = Temperature

D = Pressure

Function

B = Limiter

R = Controller

S = Switch

W = Detector

WÜL = Water monitoring for conductivity (acids, alkalis, raw water etc.)

WÜF = Water monitoring for ingress of foreign matter (oils, fats, grease, etc.)

**Year of approval
or extension**

VdTÜV Bulletin

Classification societies for marine applications

- GL Germanischer Lloyd
- LR Lloyd's Register
- See BG See-Berufsgenossenschaft
- RINA Registro Italiano Navale
- ABS American Bureau of Shipping
- KR Korean Register of Shipping
- BV Bureau Veritas
- DNV Det Norske veritas

Function	Equipment	Type Approval Number
	NRGT 26-1S Compact system with continuous level monitoring/ Current output 4-20 mA On-off control NRS 2-51 Continuous control KS 92-1 NRR 2-50	GL 99249-12 HH LR 98/20074 (E4) BV 10617/CO BV DNV-GL A-13857
"SMART" water level limiter ("high integrity design") with periodic self-testing routine (loss of redundancy)	NRG 16-50S NRS 1-50, 1E, 15 sec. In addition with positive-action safety relay and certified to SIL 3	*)DNV-GL TAA000XXX LR 01/20076 DNV A-13857 BV 25802/BO BV
Combination electrode Water level controller Output 4-20 mA with 1 "SMART" water level limiter with periodic self-testing routine (loss of redundancy)	NRG 16-38S NRS 1-50, 1E, 15 sec. In addition with positive-action safety relay and certified to SIL 3	*)DNV-GL TAA000XXX LR 01/20026 DNV-GL A-13857 KR HMB06190-MS002
Combination electrode Water level controller Output 4-20 mA with 2 "SMART" water level limiters with periodic self-testing routine (loss of redundancy)	NRG 16-39S NRS 1-50, 1E, 15 sec. In addition with positive-action safety relay and certified to SIL 3	
"SMART" Safety temperature limiter ("high integrity design") with periodic self-testing routine (loss of redundancy)	TRS 5-6.. / TRS 5-50	*) DNV-GL TAA000XXX
Conductivity monitoring with automatic temperature compensation – feedwater –	LRGT 16-1	*) DNV-GL TAA000115C
	LRG 16-9	GL 60444-09 HH
	LRS 1-7	
Cooling water monitoring – closed cycle –	ORGS Compact system	*) DNV-GL TAA00000A1 LR 07/20031 BV 17515/CO BV
Condensate / feedwater monitoring	OR 52-5	*) DNV-GL TAA000XXX

*) The old GL approvals will soon be replaced by DNV-GL. For the time being not all new approvals are available.

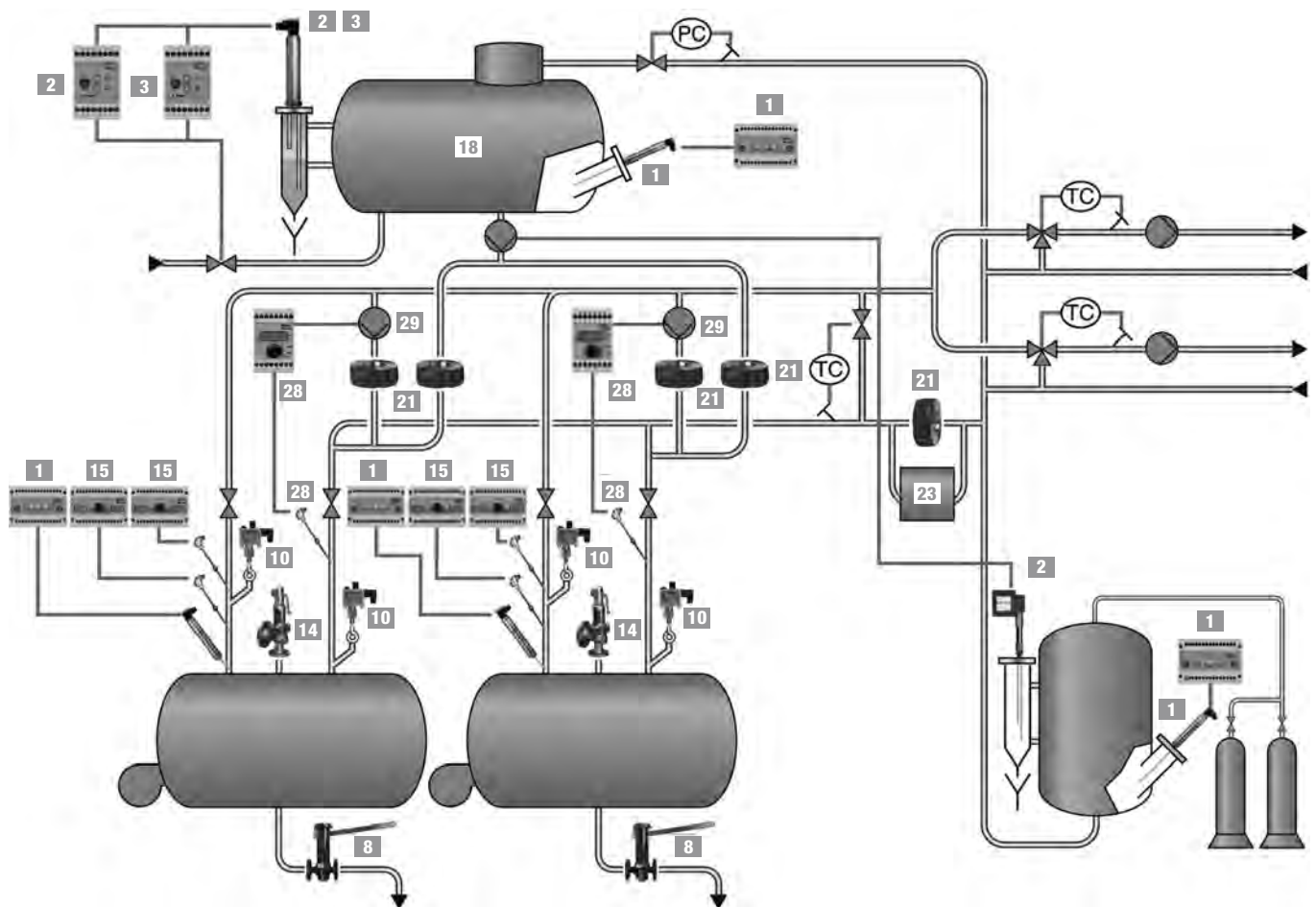

Item	Function	Measuring point	EN 12953	TRD 604
1	"SMART" Low level limiter ("high integrity design") level electrode NRG 16-50, level switch NRS 1-50, SIL 3	LSZA-	●	●
2, 3	Water level control with high level alarm, remote water level indication, level electrode NRG 16-52, level controller NRS 1-54, NRS 1-52 (HW)	LICSA+	●	●
8	Intermittent blowdown valve PA for manual boiler blowdown	QC	●	●
10	Pressure limiter DSH (+), DSL (-)	PSZA+ (-)	●	●
14	Safety valve GSV	PSV		
15	Safety temperature monitor / (limiter) Resistance thermometer TRG, temperature switch TRS 5-50, SIL 3	TSZA+	●	●
18	Feedwater tank			
21	Non-return valve			
23	Monitoring of condensate return	QISZA+	●	●
28	Raising of return temperature, resistance thermometer TRG, temperature switch TRS 5-52	TC-	●	●
29	Mixing pump			

Principles of Measurement

Conductivity measurement

The water level is detected between the electrode tips and the vessel wall (or reference electrode) and evaluated for control or limitation purposes. In this case it is essential that the medium is electrically conductive.

The high-integrity self-monitoring design of the level alarms ensures constant supervision of the insulating seal and electrode entry, immediately recognizing malfunctions in the system and failure of the electrode or supply cables. In addition, the equipment features periodic self-checking of the electronic control unit and the corresponding output contacts. Boilers of group IV require "SMART" (self-monitoring and routine testing) equipment.

Before installation, the length of the conductivity electrode rods must be cut to the required switching levels.

Capacitance measurement

Electrode rod and vessel wall (or reference electrode) form a capacitor; air and the fluid to be controlled act as dielectric. Due to the different dielectric constants of air and boiler water the capacitance value between the electrode and the vessel wall changes concurrently with level changes.

The switchpoints can be continuously adjusted during operation and multiplied by connecting in parallel several electronic control units.

Types of Controls

Water level limiters

(High-level/low-level alarms)

As soon as the water level exceeds or falls below the adjusted switchpoints the burner protection circuit is interrupted (low level) or the feed pump is switched off (high level).



On-off level control

The water level is controlled between two fixed or adjustable switchpoints. The signals are directly transmitted to the feed pump or valve.

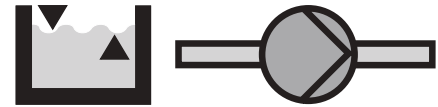

Modulating level control

The water level is continuously monitored and the actual value is compared with the adjusted set point by the associated controller. If a deviation between the two values is detected, a signal will be sent to the control valve to re-adjust the flowrate accordingly, thereby enabling a more economic and efficient steam plant operation.

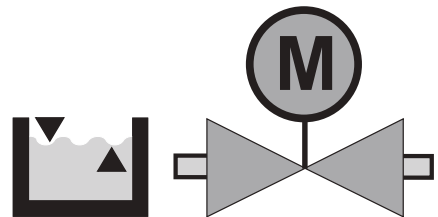

Field Bus System

Digital Data Exchange

SPECTORconnect

The SPECTORconnect system transfers the digitized measurement data acquired by the level probe to the electronic control unit located in the control cabinet. The centerpiece of this system is the stable and sophisticated CANbus (Controller Area Network). Several sensors and switches can be interconnected via one bus line.

Apart from active cable monitoring a CANbus system offers a host of benefits, such as increased design flexibility, reduced installation effort, optimized open and closed loop control, centralized operation and remote monitoring.

The standardised network opens up highly flexible possibilities for configuration. The CANopen protocol is used nowadays in medical equipment, electronic devices for marine applications, public means of transport and in burner and boiler controls of power plants.

Thanks to the many CANbus applications a great number of equipment and interface components are widely available, providing an ideal addition to our product range.

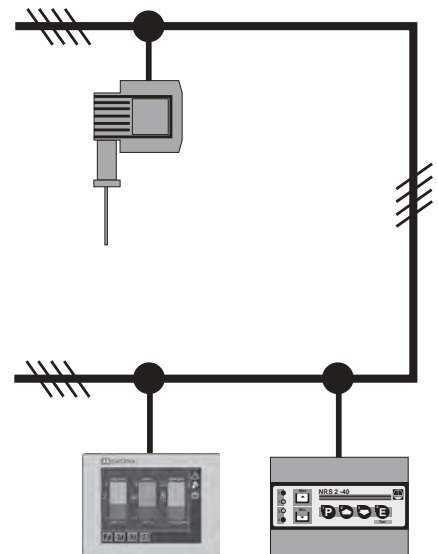

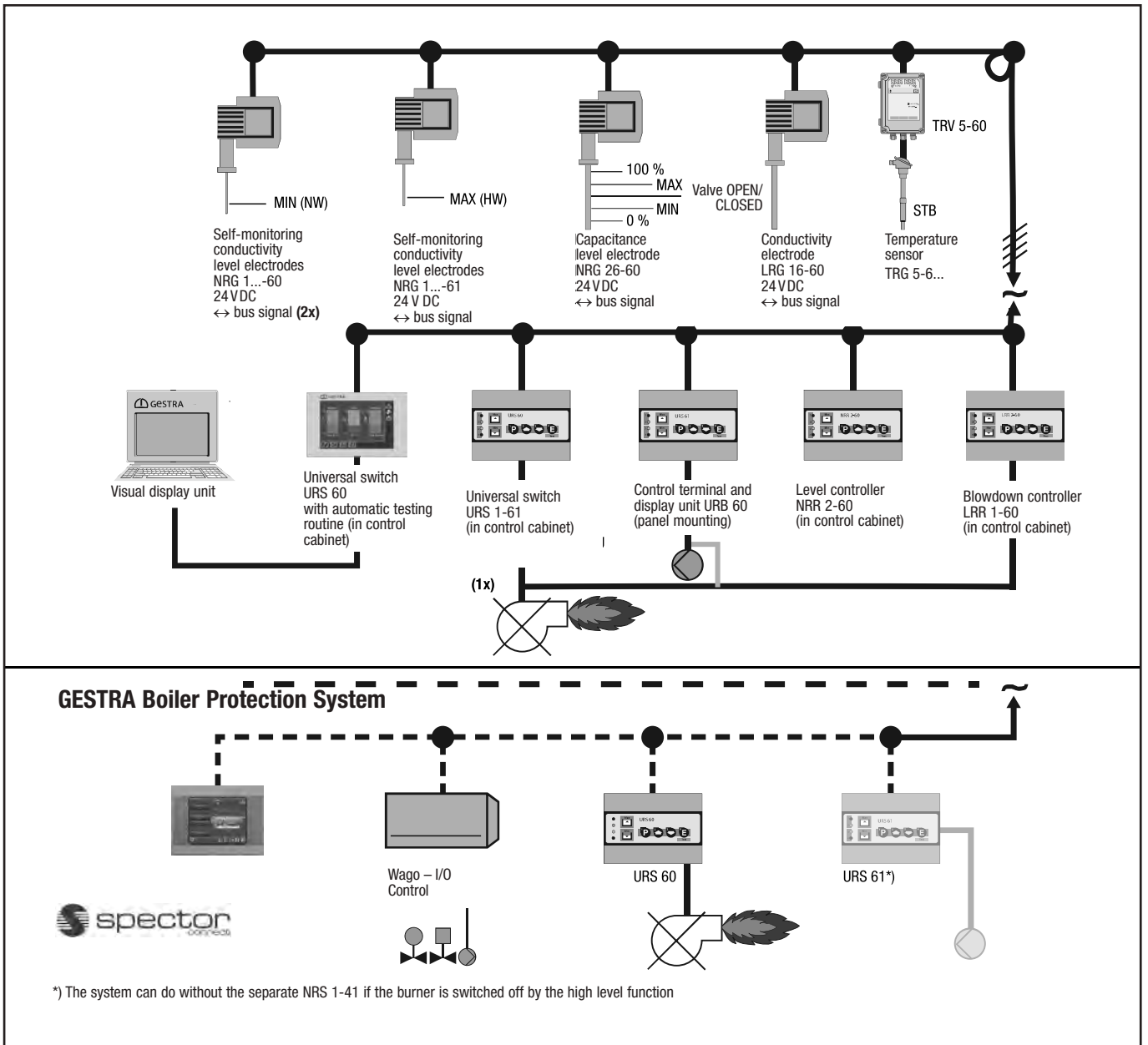

GESTRA SPECTOR*connect* boiler equipment:

The SPECTOR*connect* system digitally transmits measurement data from the probe to the electronic control unit in the control cabinet. It does this by means of a stable, sophisticated CAN (Controller Area Network) bus.

Several sensors and amplifiers can be interconnected by means of a CAN bus line. In addition to the active cable monitoring achieved in this way, the system offers numerous advantages for the planning, installation, display and optimisation of open-loop and closed-loop control systems, and enables problem-free link-up with other open bus systems.

The standardised network offers extremely flexible configuration options. In combination with the SPECTOR*control* open/closed-loop control, display and operator system, the SPECTOR*connect* can achieve bidirectional communication with the burner control, the central control room or – via UMTS – with the service partner.



The reliability of water level limiters made by GESTRA exceeds the requirement of the EN directives for SIL 2 safety chains. The system consists of two electrodes and one level switch.

The system is self-monitoring and features positive-action safety relays, extensive fault analysis for rapid detection of malfunctions and separate error messaging for both limiters.

The system is SIL 3 certified.



B

Level Limitation

Low-Level Limiter

Control unit URS 60 in conjunction with **one** level electrode type NRG 16-60, 17-60, 19-60 or 111-60 constitutes a high-integrity self-monitoring low-level limiter with periodic self-checking and automatic routine testing of output relay contacts. Function:

- Low-level alarm with **one** switchpoint.

The equipment detects min. water level (low-level alarm).

Application in steam and pressurized hot-water boilers according to EN 12952/..53 and TRD 604.

Control unit URS 60 in conjunction with **two** level electrodes type NRG 16-60, 17-60, 19-60 or 111-60 constitutes a high-integrity self-monitoring low-level limiting **system** with periodic self-checking. The control unit features the following function:

- Low-level alarm with **two** switchpoints.

The equipment combination detects low-water level (low-level alarm **system**).

Application in steam and pressurized hot-water boilers according to EN 12952/..53 and TRD 604.

The electric device complies with the regulations for safety circuits to DIN EN 50156.

The liquid level data are transferred from the electrode NRG 1...-60 to the control unit via CAN bus, using the CANopen protocol.

The safety temperature limiter type TRG 5-6./TRV 5-60 can be added to the system; for more information refer to pages 124 – 125.

High-Level-Alarm

Control unit URS 1-61 in conjunction with **one** level electrode type NRG 16-61, 17-61, 19-61 or 111-61 constitutes a high-integrity self-monitoring high-level alarm system with periodic self-checking and automatic routine testing of output relay contacts. Function:

- High-level alarm

The equipment detects the max. water level.

Application in steam and pressurized hot-water boilers according to EN 12952/..53 and TRD 604.

The electric device complies with the regulations for safety circuits to DIN EN 50156.

The liquid level data are transferred from the electrode NRG 1...-61 to the control unit via CAN bus, using the CAN open protocol.

Boiler Protection System

Description

The control unit URS 60 in combination with **two** level electrodes NRG 1.-60, the temperature sensor TRG 5-6./TRV 5-60 constitutes a self-monitoring boiler protection system with periodic self-testing and continuous monitoring of the output relays. The control unit features the following functions:

- Low-level alarm with **two** switchpoints

The equipment combination detects the min. water level (low-level limiting **system**).

- Safety temperature limiter

The equipment combination detects the max. allowable temperature.

- High-level alarm

The equipment combination detects the max. water level.

- Or other customized combination.

If more than four limiters are required, the control unit URS 61 can also be integrated in the system.

Application in steam and (pressurised)

hotwater plants in accordance with EN 12952/..53 bzw TRD 604.

The electrical equipment meets the requirements of the regulations for safety circuits according to DIN EN 50156.

The data of the sensors are transferred to the control unit via CANbus, using the CANopen protocol.

Technical Data

Type	Pressure rating	End connection	Service pressure [bar] / Saturated steam temperature	Lengths supplied [mm]	Ambient temperature [°C]
NRG 16-60	PN 40	¾"	32 / 238	500 – 3000	70
NRG 17-60	PN 63	¾"	60 / 275	500 – 3000	70
NRG 19-60	PN 160	¾"	100 / 311	500 – 3000	70
NRG 111-60	PN 320	1"	183 / 357	500 – 3000	70
NRG 16-61	PN 40	¾"	32 / 238	500 – 1500	70
NRG 17-61	PN 63	¾"	46 / 260	500 – 1500	70
NRG 19-61	PN 160	¾"	100 / 311	500 – 1500	70
NRG 111-61	PN 320	1"	183 / 357	500 – 1500	70

Self-monitoring low-level alarm system to TRD 604 (24/72 hrs without constant supervision)/EN 12952/53

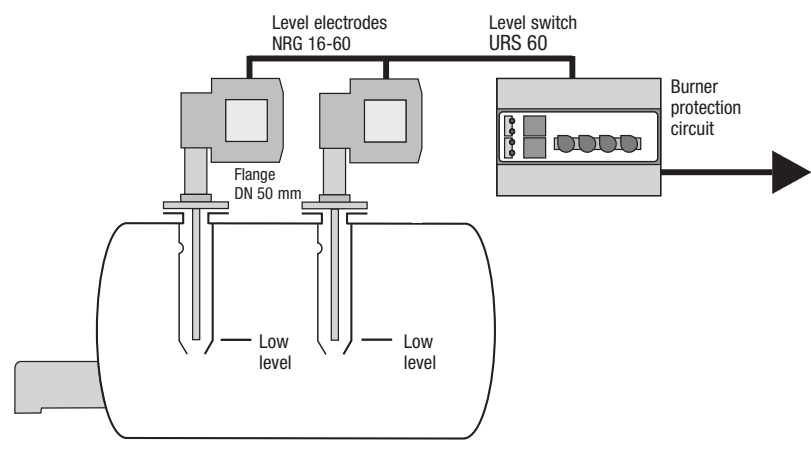

High-level alarm TRD 604, 72h

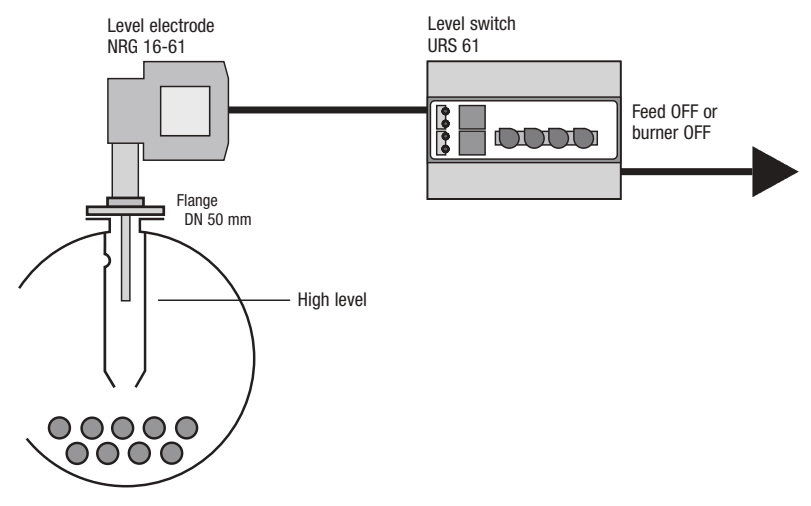

Self-monitoring boiler protection system TRD 604 24h/72h / EN 12952/53

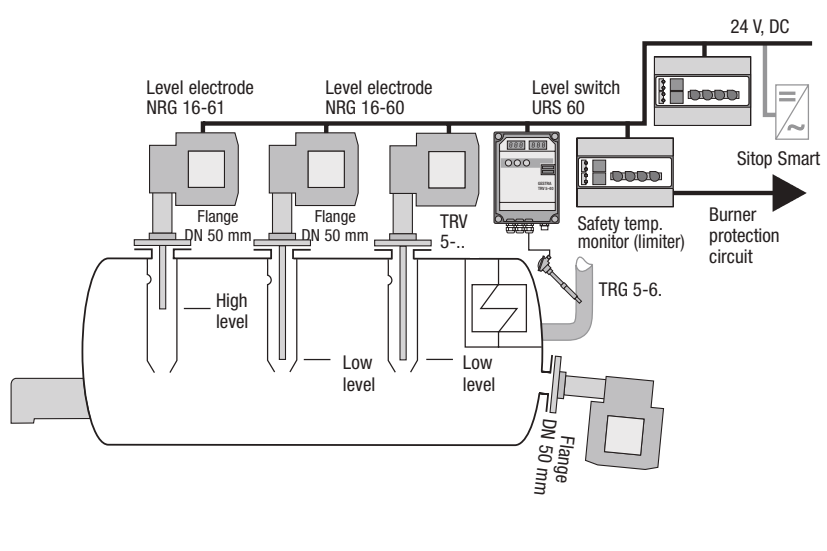

Type		PN	Stock code
NRG 16-60	1000 mm	40	3831042
URS 60	24 V DC		3356041
NRG 17-60	1000 mm	63	3832042
URS 60	24 V DC		3356041
NRG 19-60	1000 mm	160	3833042
URS 60	24 V DC		3356041
NRG 111-60	1000 mm	320	3356041
URS 60	24 V DC		3834042

SIL 3
If supervision is limited, the system can be operated with one electrode.



Type		PN	Stock code
NRG 16-61	500 mm	40	3841041
URS 61	24 V		3356141
NRG 17-61	500 mm	63	3842041
URS 61	24 V		3356141
NRG 19-61	500 mm	160	3843041
URS 61	24 V		3356141
NRG 111-61	500 mm	320	3834042
URS 61	24 V		3356141

SIL 3

For flanges see Price List

Type		PN	Stock code
NRG 16-60	1000 mm	40	3514042
TRG 5-65			2671611
TRV 5-60			2691040
LRG 16-60	300 mm	63	3791044
URS 60			3356041
NRG 16-61	500 mm		3841041
URS 61	24 V	160	3356141
NRG 17-60	1000 mm		3544042
TRG 5-65			2671611
TRV 5-60		63	2691040
LRG 16-60	300mm		3792044
URS 60			3356041
NRG 17-61	500 mm	160	3842041
URS 61	24 V		3356141
NRG 19-60	1000 mm		3574042
TRG 5-65		63	2671611
TRV 5-60			2691040
URS 60			3356041
NRG 19-61	500 mm	160	3594141
URS 61	24 V		3356141

Optional: URS 60, 230 V 3386043

SIL 3
TRG 5-6... / TRV see page 124-127

Level Controller NRR 2-60

– type approved –

- 3-position PI stepping controller with High and Low level alarm
- Optional: 3-element control
- Supporting rail for installation in control cabinets

Input:

- Capacitance level electrode NRG 26-60
- CANopen input signal
- 1 input for feedback potentiometer 0 - 1000 Ω
- For connecting the operating unit URB 60

Output:

- 1 volt free changeover contact for valve Open / Stop / Closed
- 1 actual value current output 4 - 20 mA
- Protection: IP 40
- Supply connection: 24 V DC; 4 W
- Weight: 0.8 kg

Level Controller NRR 2-61

– type approved –

- Continuous-action PI controller with two High and two Low level alarms
- Optional: 3-element control
- Supporting rail for installation in control cabinets

Input:

- Capacitance level electrode NRG 26-60
- 2 inputs 4 - 20 mA for flow metering
- CANopen input signal
- 1 input for feedback potentiometer 0 - 1000 Ω
- For connecting the operating unit URB 60

Output:

- 1 current output 4 - 20 mA for valve control
- 1 actual value current output 4 - 20 mA
- 4 volt free changeover contacts for High/Low level alarm
- Protection: IP 40
- Supply connection: 24 V DC; 4 W
- Weight: 0.8 kg

Operating & Display Unit URB 60

For panel mounting 136 x 96 mm

Input:

- Interface for data exchange with SPECTOR*connect* system

User interface

- Touchscreen, analog, resistive, resolution 640 x 480 pixels

- Illuminated

Electrical connection:

- 1 three-pole connector for voltage supply
- 1 nine-pole D-SUB connector for SPECTOR*connect*

Ethernet interface

- MODbus TCP

- Supply connection: 24 V DC, 8 VA

Protection:

- Front: IP 65
- Back: IP 20
- Weight: 1.0 kg

Capacitance Level Electrode NRG 26-60

– type approved –

For continuous signalling of liquid levels

- Pressure rating PN 40
- Measuring range: H = 300 – 2000 mm
- Connection: G ¾" EN ISO 228-1

Materials:

- Housing: 1.4571
- Measuring electrode: 1.4571
- Electrode insulation: PTFE
- Terminal box: 3.2161 (G ALSI8CU3)

Output:

- Incorporated in SPECTOR*connect* system Display & Operation
- Male/female connector M12 with 5 poles, A coded
- Seven-segment display with rotary push button
- Supply voltage: 24 V DC, 4 VA
- Protection: IP 65
- Weight: 2.0 kg

**On-off control with adjustable switchpoints
SPECTORconnect**

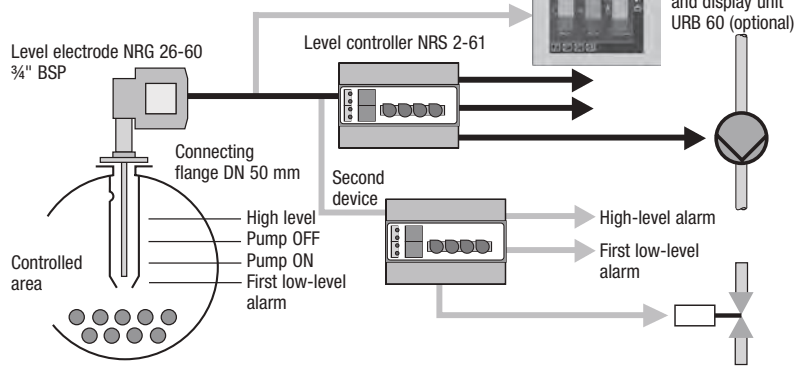

Type		PN	Stock code
NRG 26-60	H = 1000 mm	40	3496047
NRS 2-61	24 V		3246141
Optional: URB VDU			3386043



**Modulating control with
high-level alarm and
first low-level alarm
SPECTORconnect**

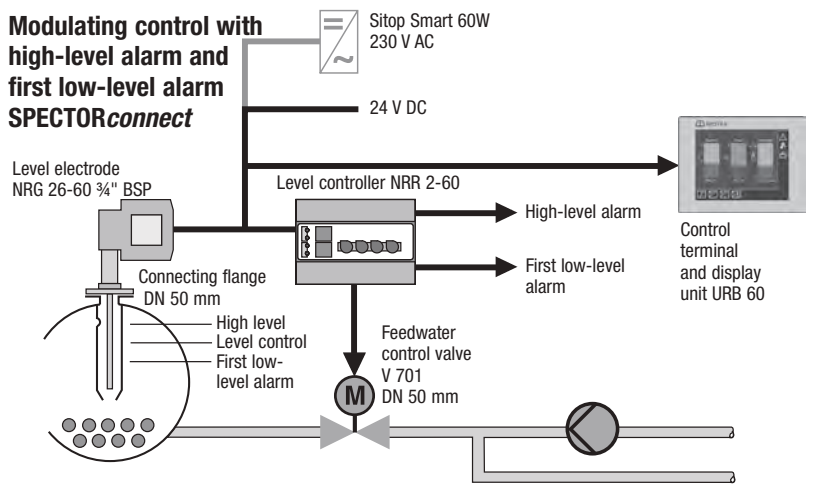

Type		PN	Stock code
NRG 26-60	H = 1000 mm	40	3496047
NRR 2-60	24 V		3246041
URB VDU			3386043



For flanges see Price List

SPECTORcontrol // - The open/closed-loop control, display and operator unit

System description

- 10.4" infrared TFT touchscreen (IP 65)
- with the following interfaces
 - 2* Ethernet for Intranet / OPC / Modbus TCP communication
 - CANopen
 - Modbus RTU RS232 for a specific burner connection
 - USB interface for backup / upload function
 - BACnet (optional)
 - Profibus DP (optional)
- Bus terminals for mounting on a support rail for a maximum of:
 - 40 digital inputs 24 V
 - 40 digital inputs for relay / volt-free
 - 20 analog inputs (4..20 mA, 10R..1K2, 0..10V, PT 100)
 - 20 analog inputs (4..20 mA, 0..10V)

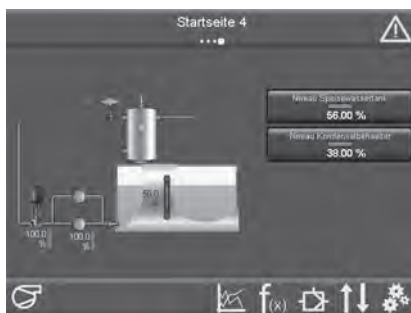

Function

The SPECTORcontrol (SC) is an open/closed-loop control, display and operating unit for a variety of uses in the control of technical equipment. All parameters, e.g. for a flowrate measurement, a steam calculator or regulator, can be set via the touchscreen with no programming knowledge.

Use of the SC means that open and closed-loop control and operator functions are all integrated in the unit. As a result, there is no need for the usual regulators from the SPECTORconnect family, such as the NRR 2-40, NRS 1-42 or URB. Additional signals are processed via an IO terminal.



The system allows the processing of digital and analogue signals, and the setting of alarm and switching thresholds. These signals can be switched directly on the regulator or further processed by the logic and calculation functions, for example. Next, they are transmitted once again via a digital or analogue output (IPO model).

A great variety of switch-specific tasks can therefore be accomplished with these signals. This reduces the control cabinet layout to a minimum. The interfaces also provide the option of retrieving data from various burner controls (Lamtec, Siemens/Landis & Staefa) and incorporating these in the open/closed-loop control and display functions.

Likewise, there is the option of forwarding all operating data via Ethernet to service partners for remote support or to central control systems, or to configure them from here.



Example regulators

- Continuous regulators
- Continuous pump regulators (FU)
- 3-position stepping regulators
- 2-position valve/pump regulators
- 3-component regulators
- Automatic intermittent blowdown control with pulse repetition
- Metering regulators

Depending on the control loop, regulators can feature the following:

- P, PI or PID characteristic
- Deadzone
- Soft start
- Automatic runtime-dependent pump switchover
- Preset operating positions



SPECTORcontrol II

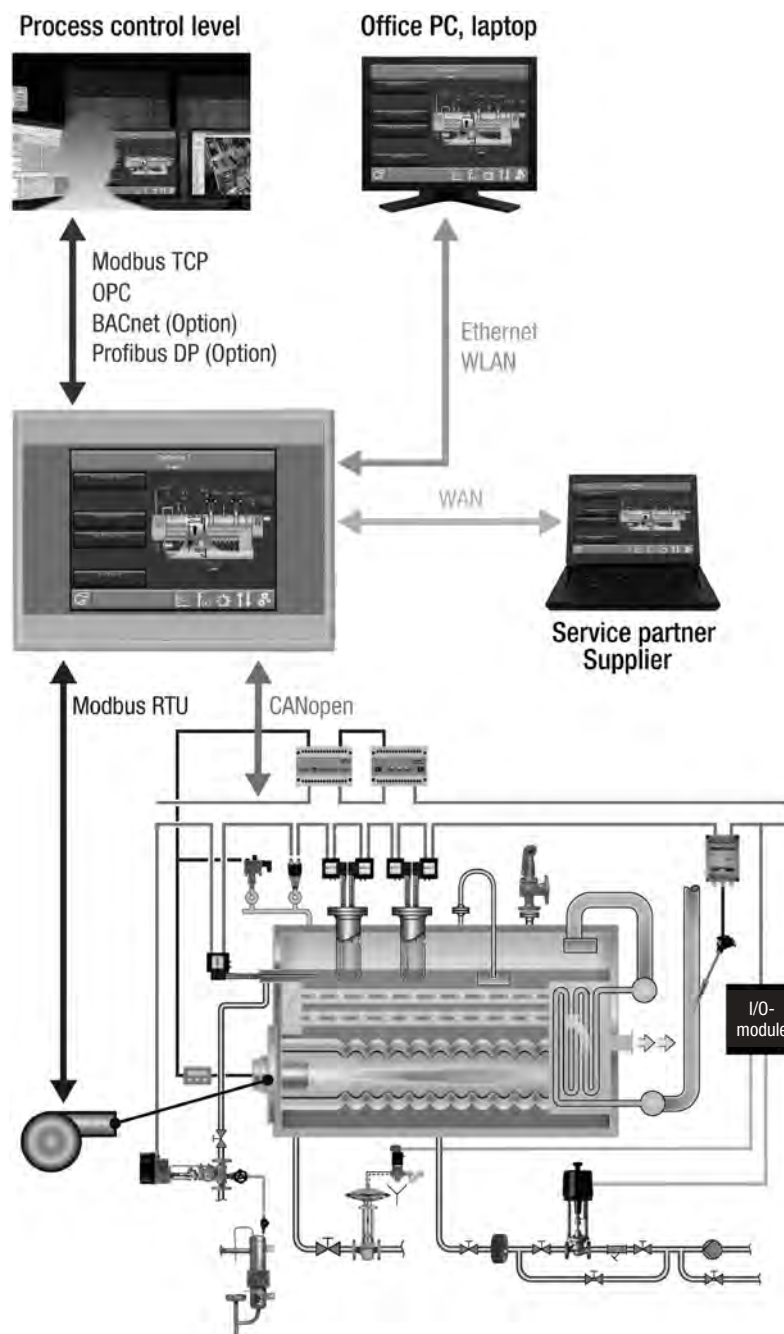

Function

Resistive touchscreen display (IP65)	10,4"
Swipe to change screens/use scrolling lists	X
Operating data display for four pages	X
Individual start screens with individual flowcharts	4
Option of individual variable positioning for start screens 3 and 4	22x
Switches/set points set directly from start screens	X
Burner control operating data display via Modbus RTU for Lamtec or Landis & Staefa	X
Operating data display for second burner control via Modbus RTU	X
Dynamic set point input and fuel switchover	X
Trend logs 5 x 4 (10 days)	X
Steam flowrate measurement (with pressure/temperature compensation)	5
Flowrate measurement (pulse/analogue)	10
Timer (weekly)	5
Maintenance logs (runtime/switching frequency)	5

Calculations (e.g. for set points)	10
Logic operations (e.g. for enabling the regulator)	20
Step sequences (e.g. for burner soft start)	5
Control loops	12
Trend-based regulator optimisation (12 x 4 > actual, set point, positioning value, position)	X
Digital inputs/outputs	40
Analogue inputs/outputs	20
CAN sensors	30
Fault log incl. freely configurable collective fault signal and initial value signal	X
Alarm history	1024
Communication via Modbus TCP, OPC, Profibus (optional), BACnet (optional)	X
SC II mutual data exchange via Modbus TCP master/slave	3
Option of remote control via standard PC, Android or IOS Remote Client	X

The SPECTORmodule Touch series is based on extensive experience gained over more than 30 years and designed for evaluating and optimizing established systems and their integral components.

The level controller NRR 2-5 offers a wide range of standard applications and features some additional extras that allow design engineers and operators to find the optimum system that meets their specific requirements.



Newly developed equipment

The name **SPECTOR*module*** stands for advanced and future-oriented system solutions, tailored to the needs and requirements of our customers. This innovative new product family combines modularity with exceptional functionality and sets new standards in various areas and sectors.

In addition to the self-monitoring and routine testing ("SMART") MIN/MAX water level limiters with EC and TÜV approval and certified functional safety SIL 3 we can now offer a safety temperature monitor/limiter that provides the same safety level.

When it comes to safety don't take any changes.

As you can see in the following table, there are two versions of the SPECTOR*module* product family:

- **SPECTOR*module*** offers all essential functions and provides significant benefits over the old conventional equipment.
- **SPECTOR*module* Touch** boasts user-friendly functions which are based on the highly advanced features of the field-proven SPECTOR*connect* product range. This system offers a host of benefits and sets the trend for technological progress.

Many of the advantages offered by the new product family are listed as follows. On the next page you will also find a synopsis of the old/new equipment and their respective functions and benefits.

SPECTOR*module*

- Compact design
- Easily accessible connecting terminals
- Supply voltage 24 V DC, which means that the equipment works independently of the national supply network
- Electrical energy is provided by reliable supply network, avoiding the need for supplementary devices such as power inverters
- Easy to use thanks to rotary button with integrated pushbutton
- Four-digit seven-segment display unit for digital readout and value indication

SPECTOR*module* Touch

- Operator control level separated from power switchgear, which means that no elaborate wiring in control cabinet is required
- User-friendly and language-independent operation thanks to intuitive colour touch screen
- Level:
 - ▶ Intuitive operation via touch screen operator panel with visual display of actual value, setpoint and value of manipulated variable
 - ▶ Trend display
 - ▶ PI control action
 - Optional:
 - Three-component control
- Conductivity:
 - ▶ Intuitive operation via touch screen operator panel with visual display of actual value, setpoint and value of manipulated variable
 - ▶ Prototype approval in acc. with WÜ 100 (VDTÜV Bulletin "Water Monitoring Equipment 100")
 - ▶ Integrated purging pulse
 - ▶ Integrated programme-controller intermittent blowdown
 - ▶ Interlocking input for preventing the simultaneous operation of two or more intermittent blowdown valves connected to one blowdown receiver

This new product family supersedes all old analogue control equipment.

When designing the new **SPECTOR*module*** product range we made sure that the new equipment will also work with existing sensors.

Description

Functional Safety

Since the international standards IEC 61508 and IEC 61511 for functional safety came into effect there has been an ever-increasing demand for analyzing equipment and process instruments that meet the requirements according to the SIL (Safety Integrity Level) classification. The European directives EN 12952 and 12953 demand that a hazard analysis shall be carried out for each limiting device function and appropriate levels of functional safety be implemented.

Note 1 states: „Typical Safety Integrity Level (SIL) requirements for boiler protective systems are not less than 2“.

Functional safety is part of the overall safety of a system that depends on the correct functioning of safety-related (sub)systems and external equipment for risk reduction.

This means that functional safety covers only one aspect of the overall safety. Other issues such as electrical safety, fire and radiation protection etc. do not fall within the scope of functional safety.

In modern systems electronic and, in particular, programmable systems perform safety functions to an ever increasing extent. As a consequence it is of utmost importance to assure the correct functioning of complex programmable systems. It is therefore essential to establish suitable methods for preventing systematic faults (usually due to human error committed during the specification and implementation phase) and for controlling failures, abnormalities and loss of function (usually physical phenomena). In this context the term “safety integrity of the protective or safety function” is used.

The European standard IEC 61508 “Functional safety of electrical/electronic/ programmable electronic safety-related systems” defines procedures, techniques, measures etc. for the functional safety of E/E/PE systems.

Water-level limiter

NRG 16-50 / NRS 1-50 b

Application and Purpose

The level electrode NRG 16-50 in conjunction with level switch NRS 1-50 is designed as self-monitoring water level limiter with routine testing (“SMART”) acc. to the European Standards EN 12952 and EN 12953. The equipment combination detects the minimum admissible level and serves as low level limiter in steam boilers and (pressurized) hot-water installations. According to the EN body of rules two SMART water level limiters are required. The system is **SIL 3** certified in accordance with IEC 61508.

The level electrode NRG 16-50 can be combined with the following GESTRA systems:

- NRG 26 / NRGT 26 / NRR 2-52 / -53 (modulating level control)
- NRG 26 / NRGT 26 / NRR 2-50 / -51 (modulating level control)
- NRG 26 / NRGT 26 // NRS 2-50 (on-off level control)
- NRG 16-52 / NRS 1-54 (on-off level control)
- NRG 16-4 / NRS 1-52 (high-level limiter)
- NRG 16-51 / NRS 1-51 (self-monitoring high-level limiter)

The level electrode NRG 17-50 can be combined with the following GESTRA systems:

- NRG 17-51/NRS 1-51 (high-level limiter)

The level electrode NRG 19-50 can be combined with the following GESTRA systems:

- NRG 19-51/NRS 1-51 (high-level limiter)

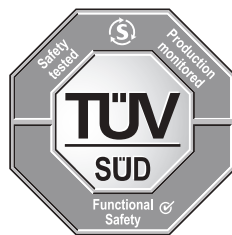

Combination of water-level limiter and controller

NRG 16-36 / NRS 1-50 / NRS 1-54

Application and Purpose

The level electrode NRG 16-36 is a combination of a water level controller and a self-monitoring water level limiter with routine testing (“SMART”) acc. to the European Standards EN 12952 and EN 12953. In conjunction with the on-off level controller NRS 1-54 the equipment detects the maximum water level (“High level limiter”) and controls the level in the boiler. In conjunction with the level switch NRS 1-50 the equipment detects and limits the minimum water level. The equipment combination is used in steam boilers and (pressurized) hot-water installations.

Design NRS 1-50

Plastic case with freely accessible terminals, for installation in control cabinets. The equipment can be snapped onto a 35 mm support rail. Field enclosure for one or more units available on request.

The system is certified to **SIL 3**.

Design NRS 1-54

Plastic case for installation in control cabinet. The equipment can be snapped onto a 35 mm support rail. Field enclosure for one or more units available on request.

Technical Data

Type	Pressure rating	End connection	Service pressure [bar g] / Saturated steam temperature	Lengths supplied [mm]	Ambient temperature [°C]
NRG 16-50	PN 40	¾"	32 / 238	500 – 3000	70
NRG 16-36	PN 40	1½"	32 / 238	1000 – 1500	70
NRG 17-50	PN 63	¾"	60 / 275	500 – 3000	70
NRG 19-50	PN 160	¾"	100 / 311	500 – 3000	70
NRG 111-50	PN 320	1"	183 / 357	500 – 3000	70

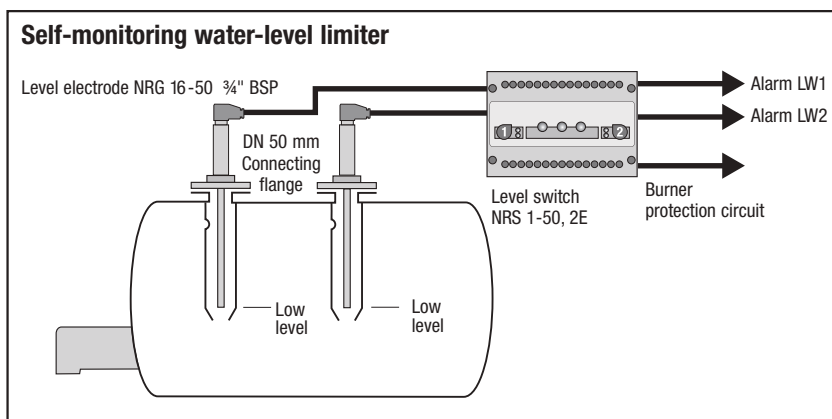

Type	PN	Stock code
NRG 16-50, L = 1000 mm NRS 1-50, 2E 24 V DC	40	3131642 3101241
NRG 17-50, L = 1000 mm NRS 1-50, 2E 24 V DC	63	3131942 3101241
NRG 19-50, L = 1000 mm NRS 1-50, 2E 24 V DC	160	3132042 3101241
NRG 111-50, L = 1000 mm NRS 1-50, 2E 24 V DC	320	3132142 3101241

Type approval
TÜV SWB 15-422
EG IS-TAF-MUC 0908 103 881 005
SIL 3



Optional: NRS 1-50
Special voltage: 100..240 V, 47..62 HZ

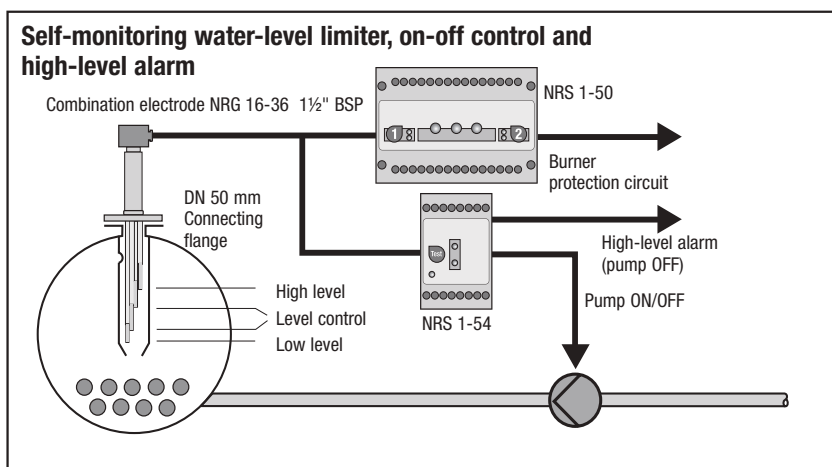

Type	PN	Stock code
NRG 16-36, L = 1000 mm NRS 1-50, 1E 24 V DC	40	3581047 3101141
NRS 1-54 24 V DC		3011441

Type approval
NRS 1-50
TÜV SWB 15-422
EG IS-TAF-MUC 0908 103 881 005
SIL 3

NRS 1-54
TÜV WB/WR 15-424

Optional: NRS 1-50
Special voltage: 100..240 V, 47..62 HZ

.50

High-Level Alarms

Description

“Conventional Design”

NRG 16-4 / NRS 1-52

Application and Purpose

Use in combination with level switch NRS 1-52 for water-level limiting (high-level alarm) in electrically conductive liquids. The austenitic version is particularly suited for aggressive fluids. For vessels and steam boilers up to PN 40 with level switch in accordance with TRD 604 (boiler operation without constant supervision). Sensing unit for high-level alarm.

Design

The level electrode NRG 16-4 is available with screwed connection $\frac{3}{8}$ "

Material: 1.4571

The electrodes are supplied in different lengths. For switching levels between these dimensions the electrode tip can be cut to length as required. Wiring to the electrode is effected by a four-pole connector.

“Self-Monitoring”

NRG 16-51 / NRS 1-51

Application and Purpose

Use in combination with level switch NRS 1-51 as self-monitoring high-level alarm with periodic self-checking according to TRD 604 sheet 1 and 2 for high-water level detection/limiting (high-level alarm) in steam and pressurized hot-water boilers.

Design

The high-level limiting system comprises level electrode NRG 16-51, NRG 17-51 or NRG 19-51 and level switch NRS 1-51.

The system is certified to **SIL 3**.

The level electrodes NRG 16-51, NRG 17-51 and NRG 19-51 consist of a measuring electrode fitted in a body. The electrode is insulated by special insulating seals.

The pressure-tight connection of the electrode is effected coaxially with a contact ring and a stud. A system of compression springs in the electrode body ensures sufficient sealing forces at the insulating seals, even if temperatures vary. The stud is insulated by a PTFE foil. Contact ring and body are connected to the four-pole connector base by PTFE insulated wires. The level electrode is available in various lengths up to 1500 mm. Observe mounting instructions (see examples of installation). The system (electrode + level switch) complies with the regulations concerning safety circuits in accordance with DIN EN 50156-1 / VDE 0116.

Technical Data

Type	Pressure rating	End connection	Service pressure [bar g] / Saturated steam temperature	Lengths supplied [mm]	Ambient temperature [°C]
NRG 16-4	PN 40	$\frac{3}{8}$ " / $\frac{3}{4}$ "	32 / 238	500 – 1500	70
NRG 16-51	PN 40	$\frac{3}{4}$ "	32 / 238	500 – 1500	70
NRG 17-51	PN 63	$\frac{3}{4}$ "	46 / 260	500 – 1500	70
NRG 19-51	PN 160	$\frac{3}{4}$ "	100 / 311	500 – 1500	70
NRG 111-51	PN 320	1"	183 / 357	500 – 1500	70

High-Level Alarms – Conventional Design

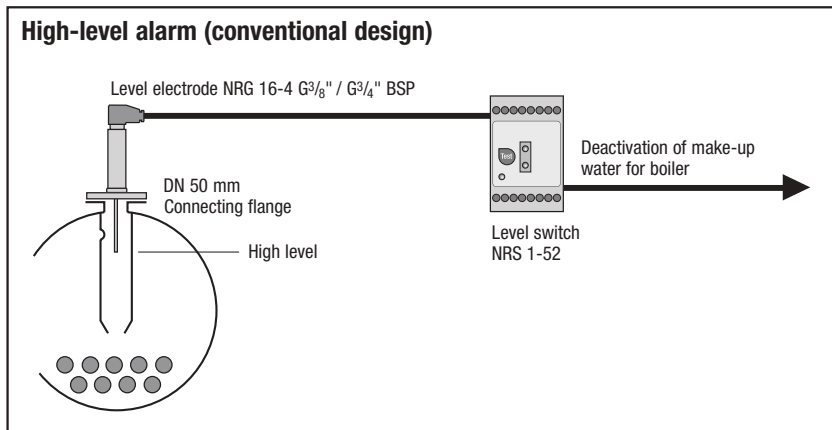

Type		PN	Stock code
NRG 16-4,	L = 1000 mm	40	3441241
NRS 1-52	24 V DC		3011241

Type approval
NRS 1-52
TÜV WB/WR 15-424

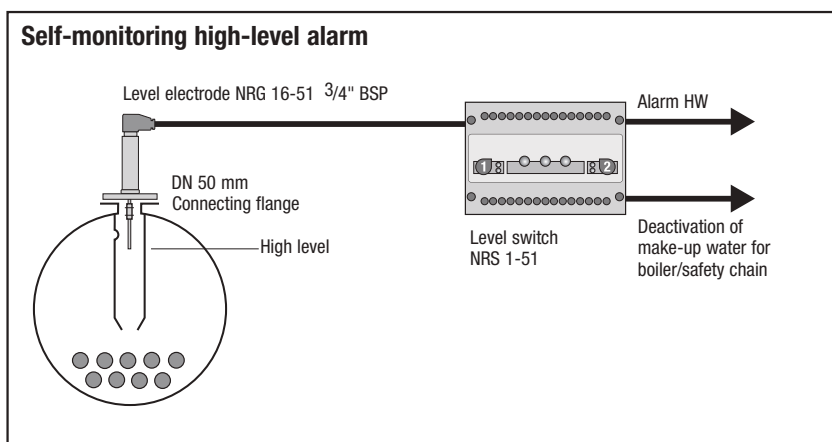

Type		PN	Stock code
NRG 16-51,	L = 500 mm	40	3132241
NRS 1-51	24 V DC		3101541
NRG 17-51,	L = 500 mm	63	3132341
NRS 1-51	24 V DC		3101541
NRG 19-51,	L = 500 mm	160	3132441
NRS 1-51	24 V DC		3101541
NRG 111-51,	L = 500 mm	320	3132541
NRS 1-51	24 V DC		3101541

Type approval
TÜV SHWS 14-423
EG IS-TAF-MUC 0908 103 881 006
SIL 3



Optional: NRS 1-51
Special voltage: 100..240 V, 47..62 HZ .50

Description

Level control

NRG 26-21 / NRGT 26-2 /

NRR 2-52 / -53

This modulating level control system comprises the level electrode NRG 26-.../ NRGT 26-2 with universal operating unit (URB 50) and the level controller NRR 2-52 / -53.

The level-dependent actual value sensed by the electrode is continuously compared by the controller with the adjusted setpoint. Any deviation is immediately detected and a signal is transferred to the motorized feed-water control valve in order to regulate the flowrate accordingly.

The level controller is a PI controller with manual control. The equipment features additional functions such as high level alarm, first low level alarm ("LoLo") and an actual value output for remote indication of the water level.

The switchpoints are adjustable within the whole measuring range of the level electrode.

The NRR 2-52 works as three-position stepping controller, the NRR 2-53 as continuous controller.

Level control

NRG 26-21 / NRGT 26-2 / NRS 2-51

This water level controller is a combination of a level electrode NRGT 26-... and a level switch NRS 2-51.

The equipment can also detect and signal high level and first low level.

Remote indication of the water level is possible if the 4-20 mA output and the LED bargraph display are used.

The advantage of this switching controller lies in customized switchpoints which can be adjusted during operation and the simultaneous use of several control units.

Level control

705 / NRR 2-52 / -53

Used in conjunction with controller type NRR for modulating water level control (pressure range > PN 40).

Can also be used as combination electrode together with limiters. The 705 is a radar-based level transducer. The reflexion time is a function of the level and will be transformed into a 4...20 mA standard output signal by the measuring transducer.

Modulating control with adjustable switchpoints

Pressure rating PN 40

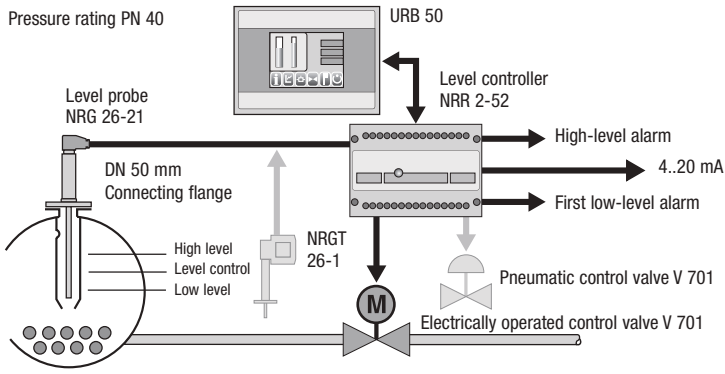

Type	PN	Stock code	
NRG 26-21	L = 1000 mm	40	3452147
NRGT 26-2	24 V DC, 4-20 mA L = 1000 mm	40	3486047
NRR 2-52	24 V DC, 4-20 mA, 3-posit. stepping, MIN, MAX	URB 50	3031241
NRR 2-53	24 V DC, 4-20 mA, continuous, MIN, MAX	URB 50	3031341

Type approval TÜV WR 17-427

Option:

3-element control (level, steam & water flowrate)

.30

Control valve with isolating bypass valve, strainer, non-return valve and feedback potentiometer

Pressure rating PN 40

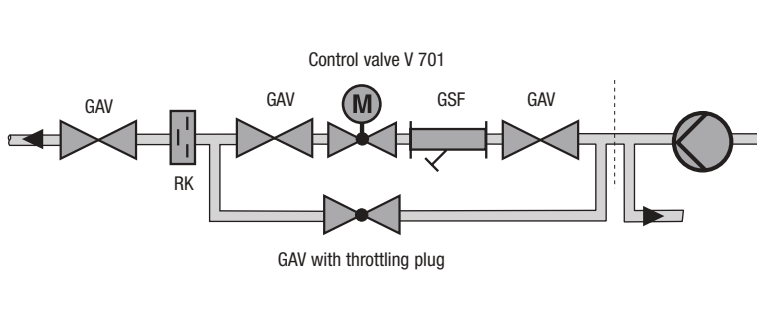

Equipment combination	Boiler capacity t/h	DN
4 x GAV 36,	< 2.5	20
Control valve V 701,	< 8.0	40
GSF, RK	< 16.0	50
230 V, 50 Hz	< 28.0	65

On-off control with adjustable switchpoints

Pressure rating PN 6

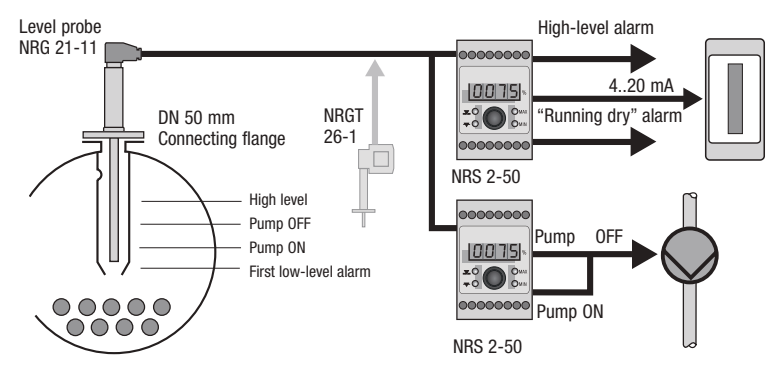

Equipment combination	Stock code	
NRG 21-11	H = 1000 mm	3421247
NRS 2-50, 4-20 mA	24 V DC	302104157
LED analogue display		1504196

Type approval TÜV WR 17-425

High-Pressure Level Control

Continuous level monitoring for high-pressure applications

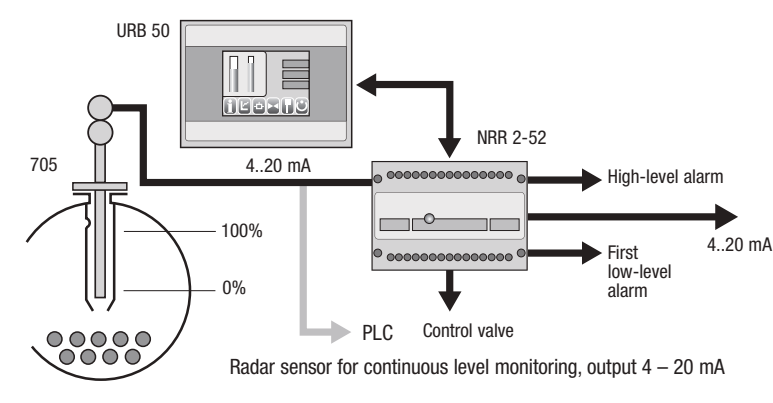

Type	PN	Design	Measuring range
705 24 V DC	100	DN 50	600
		DIN 2696 Form E	800 1000
	160	DN 50	600
		DIN	800
		Form E	1000

Approval GL

SPECTORcompact

Where formerly two devices were required, all you need now is just a single Spectorcompact. As a combined level electrode and controller, it presents the economical alternative for monitoring liquid levels in small installations and steam boilers.

Since the entire electronic control unit is located within the terminal box, the transmission path is short and reliability is higher than with comparable systems.

Features and Benefits SPECTORcompact

- Patented temperature barrier in cylindrical body above electrode flange
- Terminal box equipped with excess temperature fuse (102 °C)
- Level electrode and controller in one unit
- Optimum system adaptation thanks to modular design
- No mounting of component parts in control cabinet
 - No space requirements
 - No installation
 - No wiring
 - Easy planning
- No special cable required for wiring sensing unit to control cabinet

System Description NRGS 1...-1

The compact system NRGS 11-1 or NRGS 16-1 works according to the conductivity measurement principle. With the NRGS 1...-1 a maximum of **four** levels can be signalled in conductive liquids:

- High-level alarm, first low-level alarm, pump ON, pump OFF, with one switchpoint each.

The NRGS 1...-1 has a level switch integrated in the electrode case for the control of all functions. An external switching device is **not** required.

System Description NRGS 1...-2

The compact system NRGS 11-2, NRGS 16-2 works according to the conductivity measurement principle. With the NRGS 1...-2 a maximum of **three** levels can be signalled in conductive liquids:

- Low-level alarm, pump ON, pump OFF, with one normally open contact.

The NRGS 1...-2 has a level switch integrated in the electrode case for the control of all functions. An external switching device is **not** required.

The NRGS 1...-2 has two electrode tips for the detection of low-water level. The low-level alarm is signalled via two separate switching channels.

- Simplified logistics
 - Only one item of equipment has to be ordered and checked upon receipt
 - Reduced inventory requirements and simplified stocking
 - No onerous assignment procedures of individual component parts to mechanical engineering dept. (boiler) and measurement and control engineering dept. (control cabinet)
- Interchanges with old float-operated systems since they have their output contacts also integrated in the terminal box.

System Description NRGT 26-2

The compact system NRGT 26-2 works according to the capacitance measurement principle. The NRGT 26-2 is used for signalling different levels in conductive and insulating liquids.

- Modulating control ensures that the liquid level is always within the predefined measuring range of the electrode.

The NRGT 26-2 has a level transmitter integrated in the electrode case which produces a standard analogue output of 4 – 20 mA. An external switching device is **not** required.

Pump Control Units

Standard features	NRSP 1-51	NRSP 1-52	NRSP 2-51	NRSP 2-52
Pump protection against running dry	●	●	●	●
Pump protection against running dry and high-level alarm			●	●
Time-dependent pump switching device		●		●
Switching-on of stand-by pump				●
Single malfunction alarm			●	●
Collective malfunction alarm (visible)	●	●	●	●
Volt-free contacts	●	●	●	●
Actual value output 4-20 mA			●	●
Required sensor	NRG 1.-52	NRG 1.-52	NRG 2.-.1	NRG 2.-.1

NRGS 1.-11 / NRSP 1-5. = fixed switchpoints
NRG 2.-.1 / NRSP 2-5. = variably adjustable switchpoints

Individual control systems

for steam regenerators, desuperheaters, etc. conventional system or freely programmable (on request)

Compact system for on-off level control with fixed switchpoints

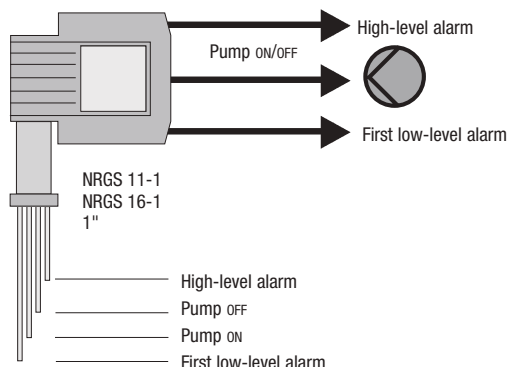

Water-level controller with two additional limit contacts, power supply 115/230 V, 50 Hz.

NRGS 11-1
NRGS 16-1
1"

High-level alarm
Pump OFF
Pump ON
First low-level alarm

Type	PN	Max. length supplied	Stock code
NRGS 11-1	6	1000	3532048
		1500	3532054
NRGS 16-1	40	1000	3533048
		1500	3533054

Optional 24 V, 50..60 Hz .51

Type approval
TÜV WRB 16-388



Compact system for water-level limitation and on-off control

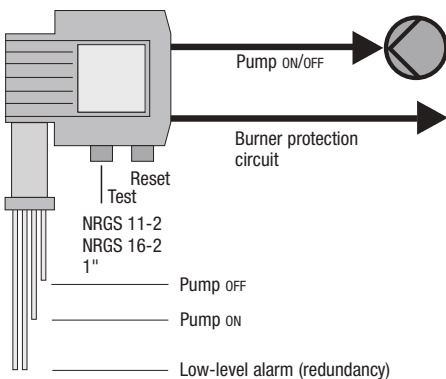

Low-level alarm and liquid level controller, power supply 115/230 V, 50 Hz.

NRGS 11-2
NRGS 16-2
1"

Pump OFF
Pump ON
Low-level alarm (redundancy)

Type	PN	Max. length supplied	Stock code
NRGS 11-2	6	1000	3532148
		1500	3532154
NRGS 16-2	40	1000	3533148
		1500	3533154

Optional 24 V, 50..60 Hz .51

Type approval
TÜV WR/WB 17-388



Compact system for modulating level control

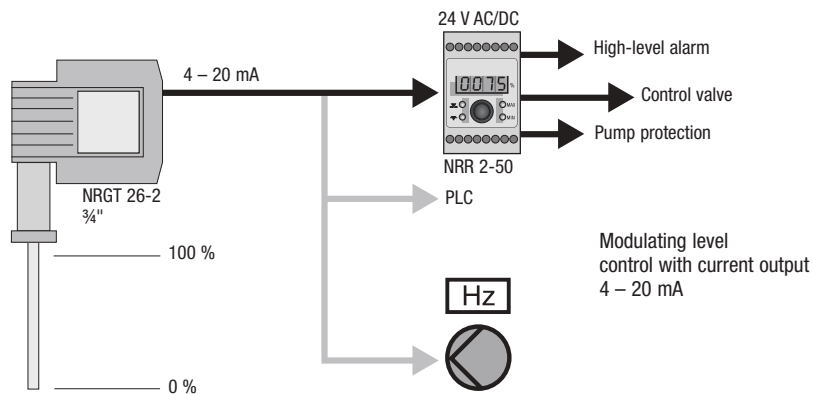

Modulating level control with current output 4 - 20 mA

NRGT 26-2
3/4"

100 %
0 %

Type	PN	Max. length supplied	Stock code
NRGT 26-2 24 V DC	40	300	3482040
		400	3482041
		500	3482042
		600	3482043
		700	3482044
		800	3482045
		900	3482046
		1000	3482047
		1100	3482048
		1200	3482049
1300	3482050		
1400	3482051		
1500	3482052		
2000	3482053		

Pump control

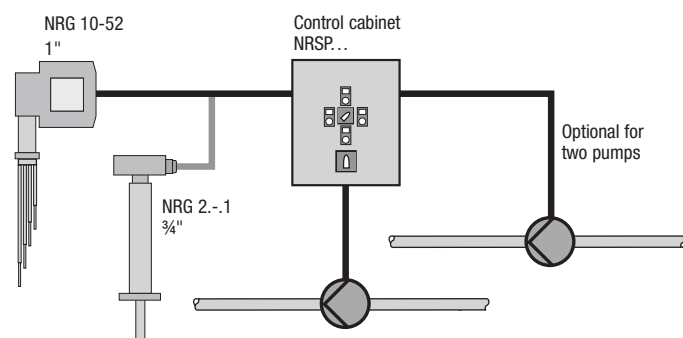

Equipment	Stock code
NRG 10-52 / NRSP 1-51	3153653 / 3265140 ...
NRG 10-52 / NRSP 1-52	3153653 / 3265240 ...

L = 1000 mm

NRG 21-11 / NRSP 2-51	3421247 / 3265340 ...
NRG 21-11 / NRSP 2-52	3421247 / 3265440 ...

H = 1000 mm / L = 1083 mm

For flanges see Price List

Description

Level pot for external installation of level electrodes

Stop Valve GAV

Purpose

For isolating and throttling non-corrosive and aggressive gases, steam and liquids, e. g. air, steam, gas, oil etc. in all industries.

GAV Features

- With stuffing box
 - Detachable locking device for all sizes
 - Optional limit switch(es)
- Y-type drain valve 17/213

Additional equipment for the external installation of liquid level alarms

SRL 6-50

Purpose

In combination with external low-level alarms for monitoring the periodic purging of level pots or, generally, as timer for monitoring any periodic function.

Particularly suitable for steam plant operation to TRD 602/604.

Design

All-electronic logic unit **SRL-50** for continuous monitoring, with three LEDs (stand-by, purging, switching off) with case for mounting on walls.

Operation

The monitoring equipment with Mini-PLC periodically activates a memory for a defined period of time. During this period the memory registers all functional operations, e. g. purging of the level pot. If this signal is not received within the fixed period, the plant is shut down. The plant is also shut down if the purging process lasts for more than five minutes.

Type code of level pots

Feature	Value	Designation	MF 206-1STT 118 P / 214 P / 312 G >
Component	Level pot	MF	
Design: (side connection)	1 Side connection	10	
	2 Side connection	20	
	4 Side connection 90°r	40	
	4 Side connection 90°l	41	
	4 Side connection 180°	42	
	6 Side connection 90°R+90°L	60	
Nominal pressure	PN 16	4	
	PN 40	6	
	PN 63	7	
	PN 160	9	
Size	88.9	1	
	114.3	2	
Material	Steel type P235GH	S	
	High-temperature steel 16Mo3	W	
	Austenitic	A	
In accordance with	AD-Bulletin	A	
	TRD	T	
	Others	S	
Approved by	TÜV (if necessary)	W	
	Works inspector		
	Others	S	
Connection (N 1)	3/4" BSP	114 G	
	1" BSP	115 G	
	1 1/4" BSP	116 G	
	1 1/2" BSP	117 G	
	DN 50 mm	118 P	
	DN 80 mm	120 P	
	DN 100 mm	121 P	
Boiler connection (N 2)	DN 15 mm	212 P	
	DN 20 mm	214 P	
	DN 25 mm	215 P	
	DN 50 mm	218 P	
Drain connection (N 3)	1/2" BSP	312 G	
	DN 20 mm	314 P	
	DN 25 mm	315 P	
Side connection 3 + 4 (N 4)	DN 20 mm	414 P	→ not required in this example
	DN 25 mm	415 P	
Side connection 5 + 6 (N 5)	DN 20 mm	514 P	→ not required in this example
	DN 25 mm	515 P	
Centre distance	≤ 1500	ME 1500	Centre distance ME = 1500 mm
Length (top)		Spec. >	Length (top) ∅ 88.9 ≥ 190 mm
Length (bottom)		Spec. >	Length (bottom) ∅ 114.3 ≥ 230 mm
			Length (bottom) ≥ 50 mm

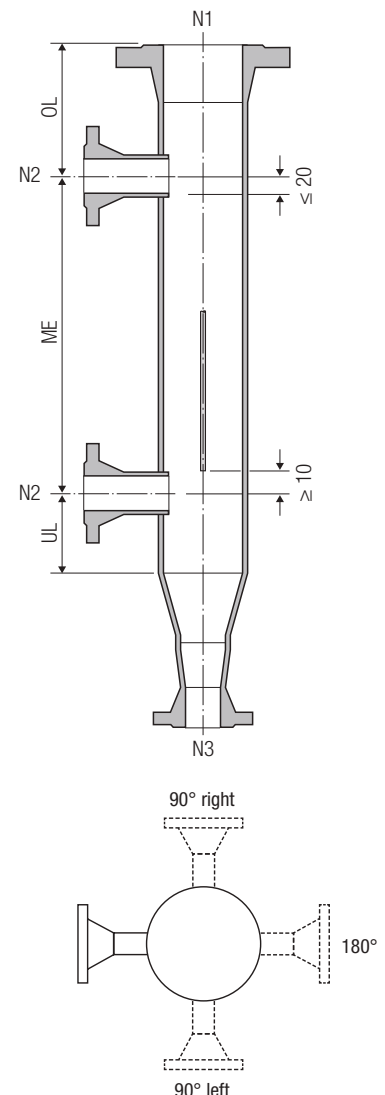

Accessories for liquid level alarms fitted in external level control pots

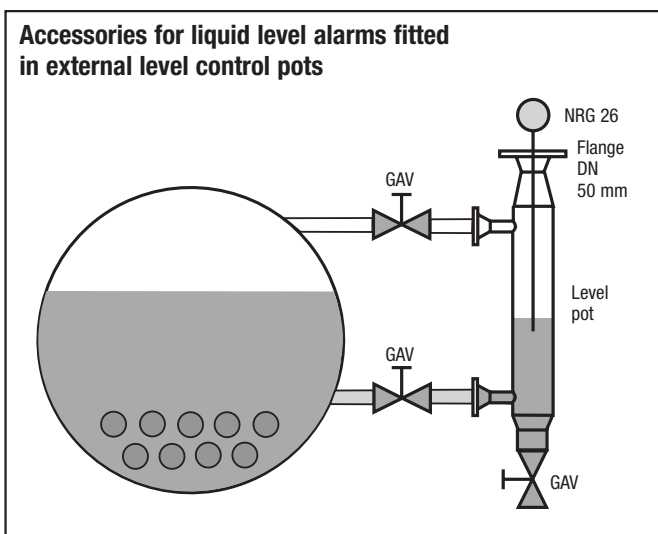

Type	PN	Pressure/Temp. Ratings	
		P_{max}	t_{max}
MF 2061 STT ¹⁾ GAV 36, DN 20 17/213, 1/2" BSP	40	28 bar	250 °C
MF 2071 STT ²⁾ GAV 136, DN 25	63	51 bar	275 °C
MF 2091 STT ²⁾ GAV 136, DN 25	160	75 bar	290 °C
MF 2091 WTT ²⁾ GAV 136, DN 25	160	100 bar 96 bar	311 °C 300 °C

¹⁾ Approval acc. to PED 2014/68/EU, module A1

²⁾ Approval acc. to PED 2014/68/EU

**Accessories for high-integrity level controls fitted in an external level control pot
SPECTOR^{module}**

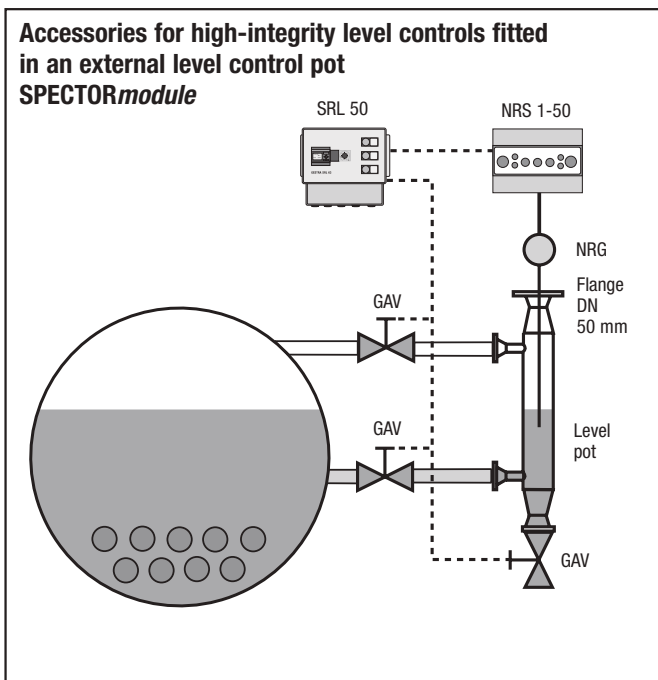

Type	DN / PN	Pressure/Temp. Ratings	
		P_{max}	t_{max}
MF 2061 STT ¹⁾ GAV 36-II GAV 36-I SRL 6-50	20 / 40	28 bar	250 °C
MF 2071 STT ²⁾ GAV 136-II GAV 136-I SRL 6-50	25 / 63	51 bar	275 °C
MF 2091 STT ²⁾ GAV 136-II GAV 136-I SRL 6-50	25 / 160	75 bar	290 °C
MF 2091 WTT ²⁾ GAV 136-II GAV 136-I SRL 6-50	25 / 160	100 bar 96 bar 96 bar	311 °C 300 °C 300 °C

¹⁾ Approval acc. to PED 2014/68/EU, module A1

²⁾ Approval acc. to PED 2014/68/EU

**Accessories for high-integrity level controls fitted in an external level control pot
SPECTOR^{connect}**

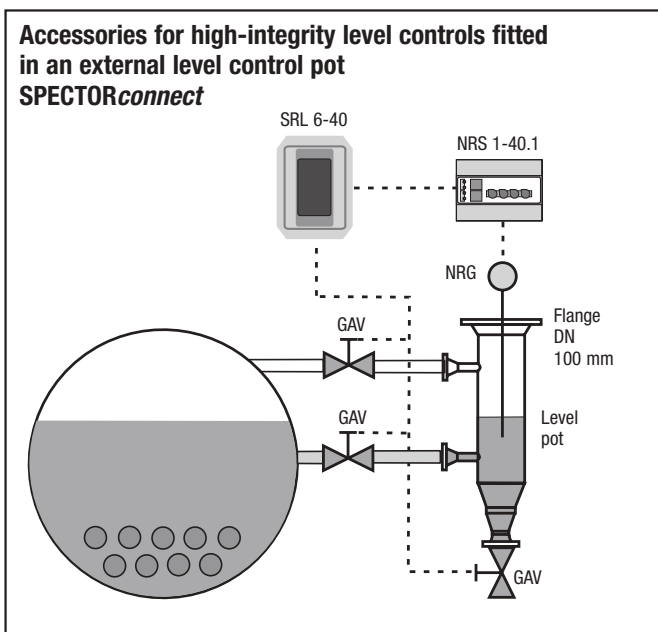

Type	PN / PN	Pressure/Temp. Ratings	
		P_{max}	t_{max}
MF 2062 STT ¹⁾ GAV 36-II GAV 36-I SRL 6-40	20 / 40	28 bar	250 °C
MF 2072 STT ²⁾ GAV 136-II GAV 136-I SRL 6-40	25 / 63	51 bar	275 °C
MF 2092 STT ²⁾ GAV 136-II GAV 136-I SRL 6-40	25 / 160	75 bar	290 °C
MF 2092 WTT ²⁾ GAV 136-II GAV 136-I SRL 6-40	25 / 160	100 bar 96 bar 96 bar	311 °C 300 °C 300 °C

¹⁾ Approval acc. to PED 2014/68/EU, module A2

²⁾ Approval acc. to PED 2014/68/EU

Optional SRL:
Voltage 115 V, 24 V, 50..60 Hz

More measuring pots see page 137

Design

The probe works without any moving parts. The probe rod, which is insulated by a ceramic tube, is inserted through a hole in the probe flange such that pressure-tight sealing is ensured. The ceramic tube is closed at the lower end and covered by a protection tube. The electronic control unit is housed in the terminal box. The wiring is effected via a 6 pole connector with crimp connection.

Operation

The principle of capacitance measurement is used to sense liquid levels. The probe rod and the protection tube form a capacitor, with air or the particular liquid being the dielectric. In electrically conductive liquids the probe insulation serves as dielectric. As the level rises or falls, the capacitance of this assembly changes, is converted in the integral measuring transducer into a signal, and is then fed to the associated electronic control unit.

NRG 211

In combination with level switch NRS 2-4 for indicating high-water level at very high pressures and temperatures (up to PN 320, 550 °C). Application in draining systems of conventional power stations and high-pressure steam boilers.

NRS 2-4

The level switch NRS 2-4 is an analogue electronic amplifier for the capacitance electrode type NRG 211.

In combination with this level electrode the unit can detect high water level. In addition, the level switch evaluates possible malfunction signals coming from the electrode and monitors the electrode supply cable and can therefore be used as part of a controlled draining system in power stations.

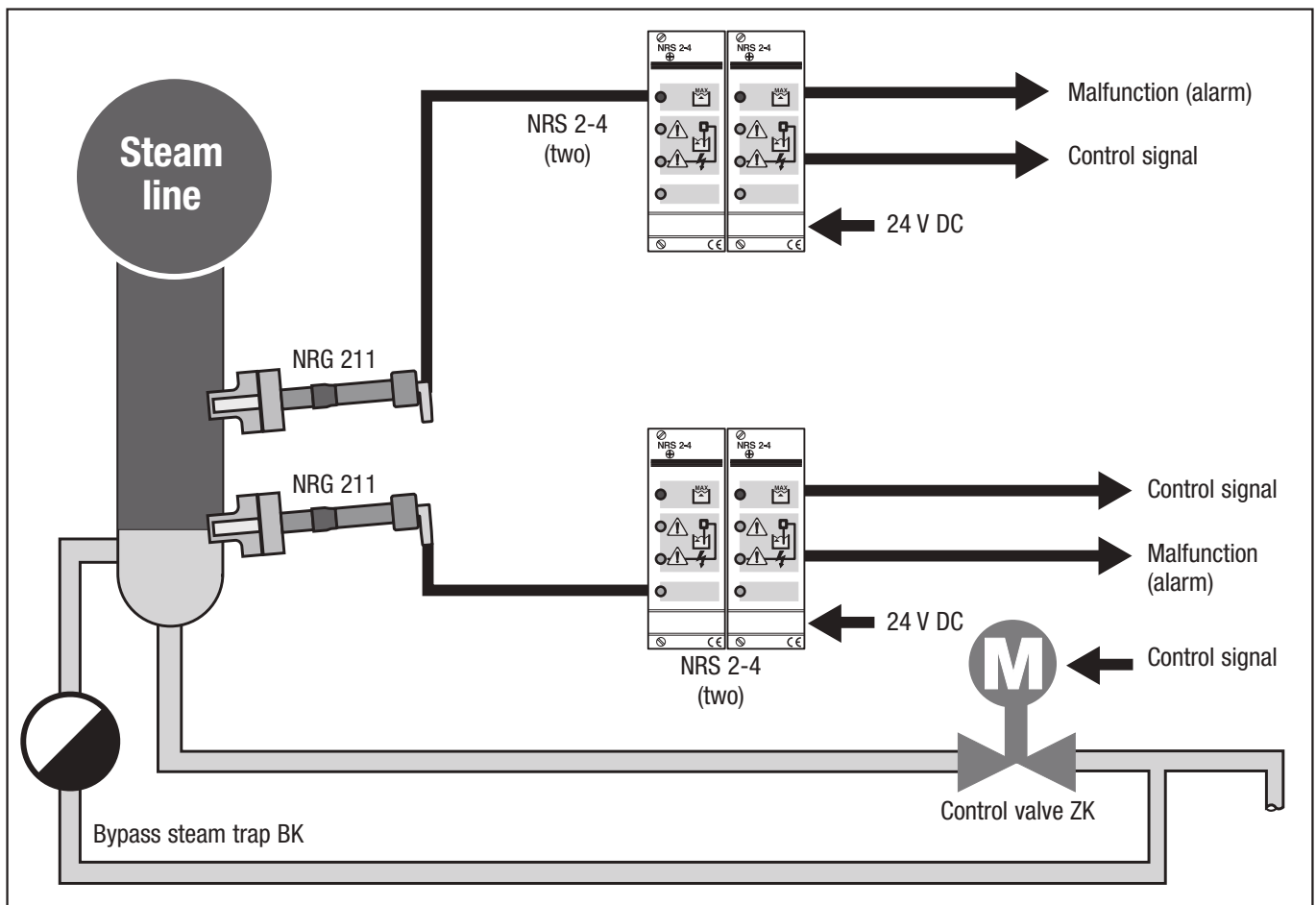

Type	Material	PN		Stock code
NRG 211 *)	1.5415	320	200 bar at 450 °C	350100130 ≤ DN 100
			320 bar at 120 °C	350100140 > DN 100
	1.7380	200 bar at 500 °C	350100231 ≤ DN 100	
		320 bar at 120 °C	350100241 > DN 100	
1.4922	230 bar at 550 °C	350100332 ≤ DN 100		
	320 bar at 120 °C	350100342 > DN 100		
NRS 2-4	HW			3233142

*) with welding connection, nuts, bolts and seals for pipes $\varnothing > \text{DN } 100$ or $< \text{DN } 100$

Description

Steam boiler equipment for marine applications has to comply with the same requirements as those placed on land installations. In addition to that further demands regarding environmental conditions such as climate, vibrations etc. have to be met.

The acceptance certificates are to be issued by the classification society responsible for the ship's acceptance inspection.

For marine applications see page 96.

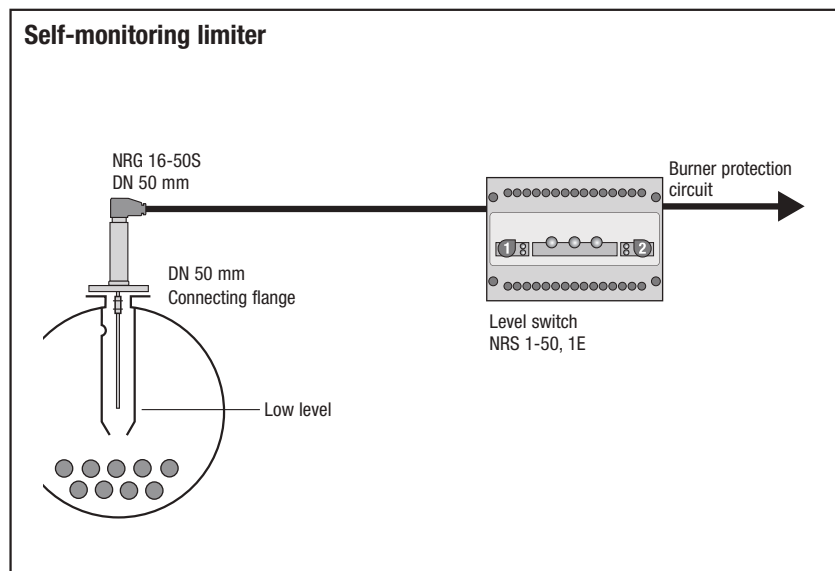

Type		PN	Stock code
NRG 16-50S	L = 1000 mm		31317742
NRS 1-50, 1E	24 V DC, 15s	40	31011415053
NRS 1-50, 2E	24 V DC, 15s		31012415053

Optional 100 – 240 V AC
NRS 1-50, for 1 electrode
NRS 1-50, for 2 electrodes

31011415053
31012415053

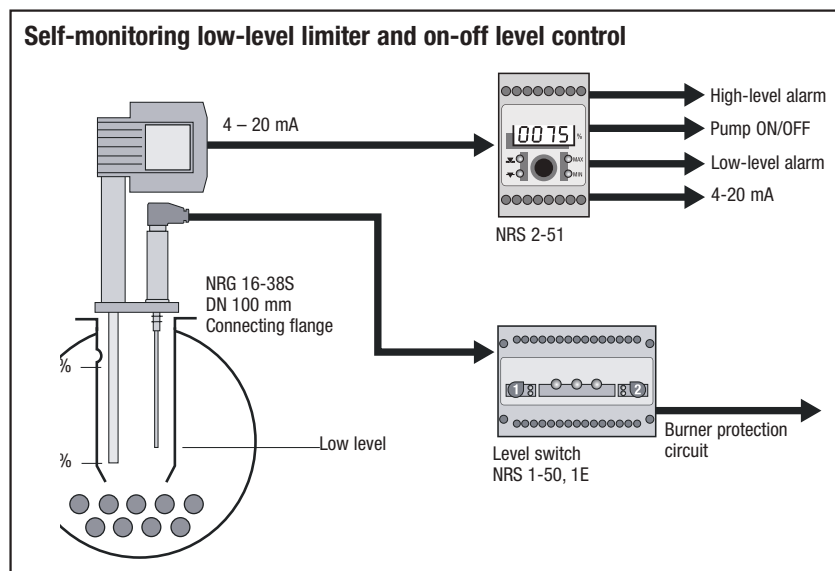

Type	PN	max. length supplied	Stock code
NRG 16-38S 24 V AC/DC	40	779	3582044.57
		884	3582045.57
		989	3582046.57
		1095	3582047.57
		1513	3582051.57
NRS 1-50, 1E, 24 V DC			310114153
NRS 2-51, 24 V DC			3021141

Optional
NRG 16-38s, 115 V 50-60 HZ
NRG 16-38s, 230 V 50-60 HZ

.56
e. g. 3582044.

Self-monitoring limiter and modulating level control

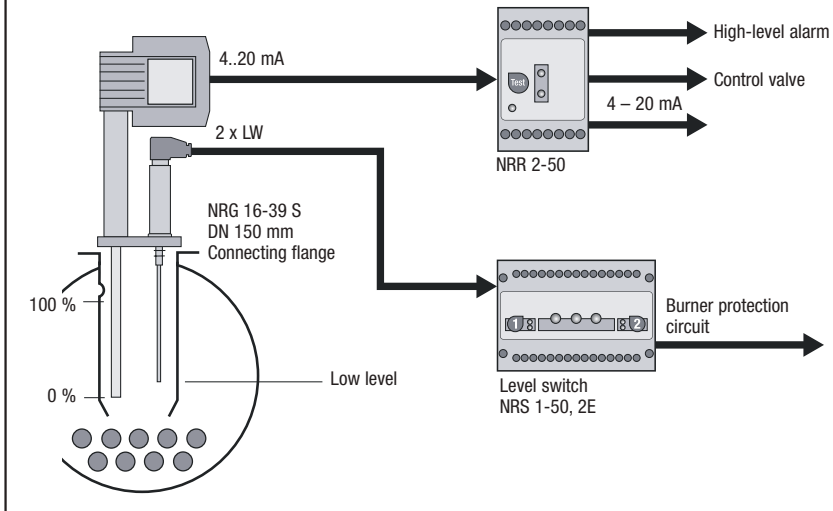

Type	PN	max. length supplied	Stock code
NRG 16-39 S 24 V AC/DC	40	779	3584044.57
		884	3584045.57
		989	3584046.57
		1199	3584047.57
	1513	3584051.57	
NRS 1-50, 2E, 24 V DC, 15s, 1x			310124153
NRR 2-50, 24 V DC			3031041

Optional
NRG 16-39s, 115 V 50-60 HZ .56
NRG 16-39s, 230 V, 50-60 HZ e. g. 3584044.
NRS 1-50, 230 V, 50-60 HZ .50.53

Compact system for modulating level control

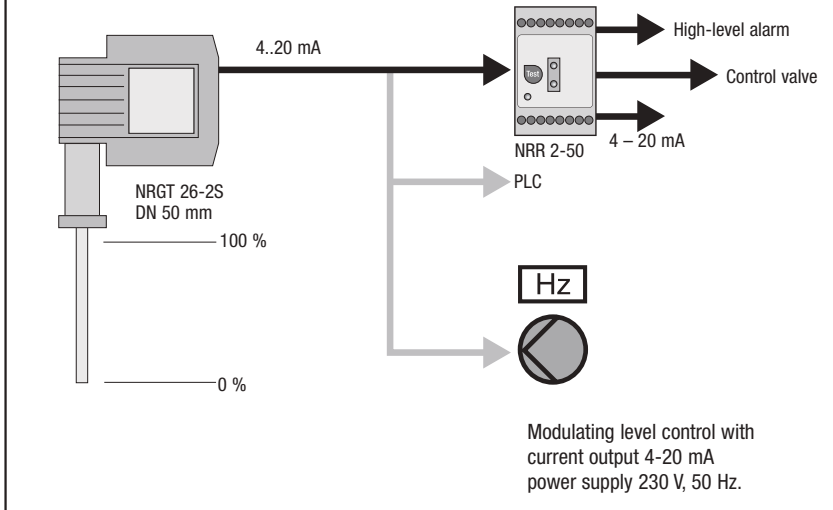

Type	PN	max. length supplied	Stock code
NRGT 26-2S 24 V AC/DC	40	316	3212052
		420	3212053
		526	3212054
		631	3212055
		737	3212056
		842	3212057
	947	3212058	
	1053	3212059	
	1579	3212060	
NRR 2-50, 24 V DC			3031041

Optional
NRGT 26-1S, 115 V 50-60 HZ .52
NRGT 26-1S, 230 V, 50-60 HZ e. g. 3211452.



Industrial Electronics

	Page
Temperature detection and control SPECTOR <i>connect</i>	124 – 125
Temperature control SPECTOR <i>module</i>	126 – 127
Conductivity Monitoring	
Basic principles · application	128
Technical specification.....	129
Conductivity monitoring SPECTOR <i>connect/compact</i>	130
Conductivity monitoring SPECTOR <i>connect/compact</i> with automatic temperature compensation ..	131
Conductivity control with manual or automatic temperature compensation SPECTOR <i>module</i>	132 – 133
Conductivity monitoring with automatic temperature compensation LRG. . . / LRS 1-7.....	134 – 135
Ancillaries	
Level pots and portable measuring instruments VRM	136
Tee pieces, level pots and portable measuring instruments VRM	137
Continuous blowdown valves	138 – 139
Programme-controlled blowdown systems	140 – 141
Rapid-action intermittent blowdown valves	142 – 143
Contamination detectors for condensate and process liquids	
Detecting ingress of oil in condensate systems and marine installations	144 – 145
Ingress of oil in cooling water systems digital indicator.....	146
Flowmeters for steam, gases and liquids	147

URS 60/61

Controller with Safety Function

Self-monitoring temperature limiter with periodic self-checking feature to be used in conjunction with a resistance thermometer type TRG 5-6.. and pre-amplifier TRV 5-60. The equipment operates as a safety temperature controller, or in conjunction with an external lock-out in accordance with DIN EN 50156 as a safety temperature limiter. An alarm is given as soon as the temperature exceeds a preset limit value. The TRV 5-60 features digital indicators for the actual temperature and switching-off temperature.

Examples of Installation

- Superheaters for steam boiler plants operating without constant supervision (TRD 604).
- Superheater cascades with up to 4 steps
- In pressurized hot-water plants as temperature limiter for the secondary circuit in accordance with TRD 604 or 12952/..53.
- Furnaces in accordance with DIN 30 683 up to 800 °C.
- Control systems for product heating or cooling

Technical Data of Temperature Sensor

Type	PN	Connections			Pt 100	Max. temperature	Ambient temperature	Lengths available L [mm]
		Screwed	TRV...	Welding stub				
TRG 5-63	40	½"	5-40	–	1	400 °C	100 °C	100 to 400
TRG 5-64	40	½"	5-40	–	2	400 °C	100 °C	100 to 400

Accuracy class A

TRG 5-65	160	–	5-40	form 4	1	540 °C	100 °C	115
TRG 5-66	160	–	5-40	form 4	1	540 °C	100 °C	140
TRG 5-67	160	–	5-40	form 4	1	600 °C	100 °C	200
TRG 5-68	160	–	5-40	form 4	1	600 °C	100 °C	200

Accuracy class A/B

Technical Data of Temperature Pre-Amplifier

Type	Output	Adjustment range	Auxiliary power	Version	Performance test	TÜV	EC
TRV 5-60	CANopen	650 °C	24 V, DC	a	annual	●	●

Technical Data of Temperature Switches / Controllers / Indicators

Type	Outputs		Control characteristic			Mains supply Standard	Version			Performance test in acc. with DIN 3440	TÜV approval	EC
	Switchpoint	0/4-20 mA	MIN	MAX	Δ T		b	c	e			
URS 60	1	–	–	–	–	230 V	●	–	–	annual	●	●
URS 61	1	–	–	–	–	230 V	●	–	–	–	●	●

Safety temperature limiter acc. to EN 12953

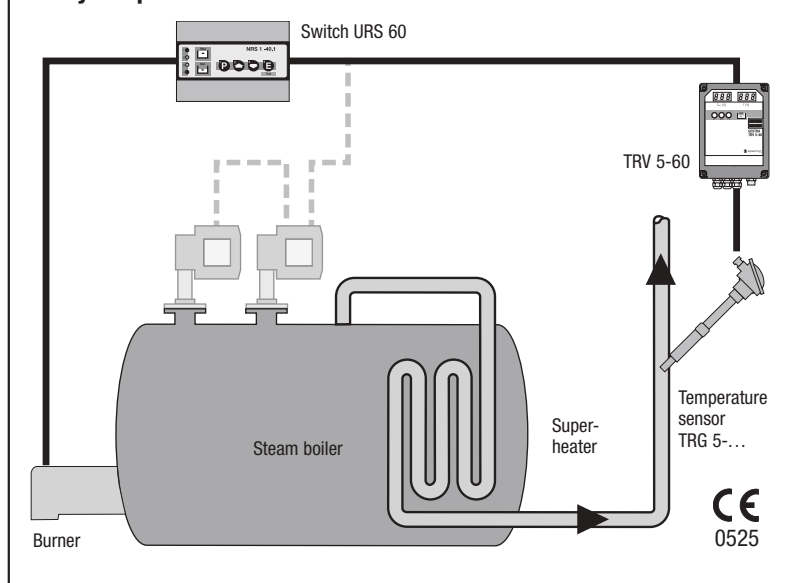

Safety temperature limiter

Combination	PN	Stock code
PT 100 T < 650 °C		
TRG 5-67 L = 200 mm	160	2671822
TRG 5-68 L = 200 mm	160	2671923
TRV 5-60 24 V, DC	-	
URS 60 24 V, DC	-	

Combination	PN	Stock code
Pt100 T < 540 °C		
TRG 5-65 L = 115 mm	160	2671611
TRG 5-66 L = 140 mm	160	2671712
TRV 5-60 24 V, DC	-	2691040
URS 60 24 V, DC	-	3222841

Type approval
TÜV SWB/SHWS/STW (STB) 13-413
EG MUC-03-07-103881-004
DIN CERTO STW (STB) 117906
SIL 2

Pressurized hot-water boiler acc. to EN 12953

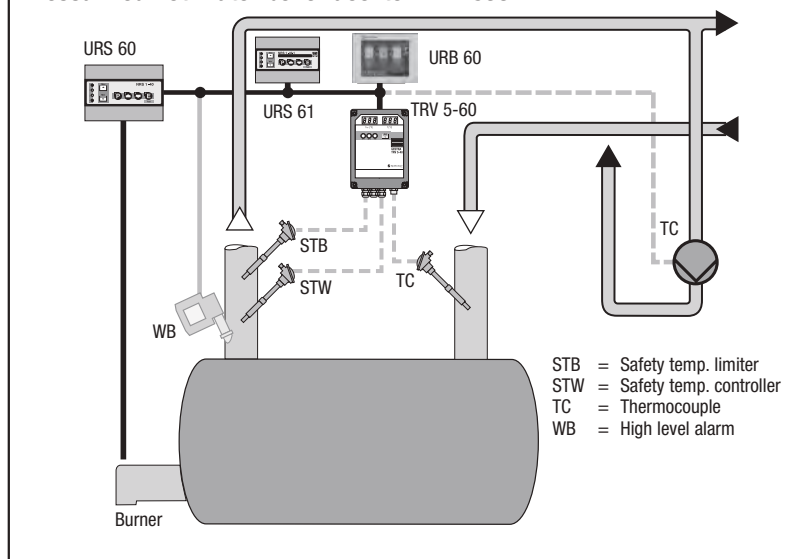

Pressurized hot-water boiler

Combination	PN	Stock code
PT 100 T < 400 °C		
TRG 5-63 L = 100 mm 3x	40	2671110
TRV 5-60 24 V, DC 1x	-	2691040
NRG 16-60	40	3514041
URS 60	-	3222841
URS 61	-	3228941
URB 60	-	3382043

TÜV STW 1182 06
DIN CERTO TR/TW 118206
SIL 2

For other PT 100 see Price List.

Pressurized hot-water boiler acc. to TRD 604

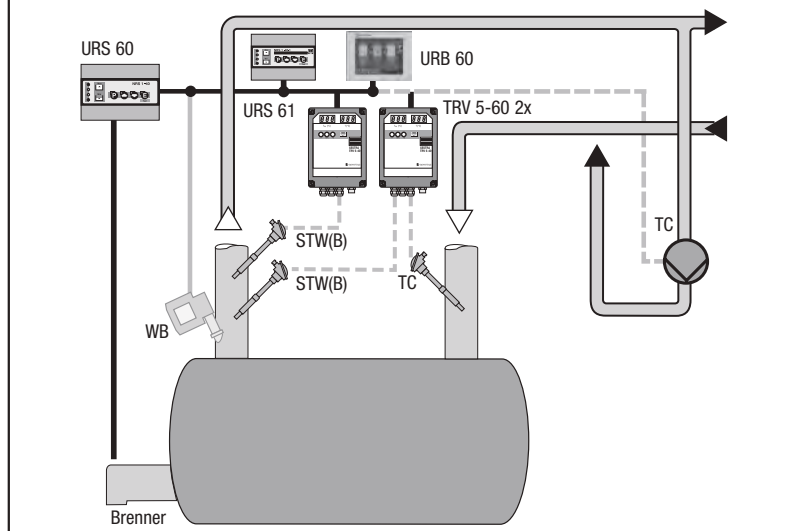

Pressurized hot-water boiler

Combination	PN	Stock code
PT 100 T < 400 °C		
TRG 5-63 L = 100 mm 3x	40	2671110
TRV 5-60 24 V, DC 2x	-	2691040
NRG 16-60	40	3514041
URS 60	-	3222841
URS 61	-	3228941
URB 60	-	3382043

TRS 5-50

Self-monitoring temperature switch with periodic self-checking feature to be used in conjunction with a resistance thermometer type TRG 5-....

The equipment operates as a safety temperature controller, or in conjunction with an external lock-out in accordance with EN 14597 as a safety temperature limiter. An alarm is given as soon as the temperature exceeds a preset limit value. Via the optional current output the temperature can be indicated externally at the same time. The system is **SIL 3** certified.



Examples of Installation

- Superheaters for steam boiler plants operating without constant supervision (TRD 604).
- In pressurized hot-water plants as temperature limiter for the secondary circuit in accordance with TRD 604 or EN 12952/..53.
- Furnaces in accordance with DIN 30 683 up to 650 °C.
- Return-temperature control acc. to TRD 604.
- Control systems for product heating or cooling.

TRS 5-52

The min./max. temperature switch TRS 5-52 in combination with temperature sensor TRG 5-63, TRG 5-64, TRG 5-65, TRG 5-66, TRG 5-67 and TRG 5-68 serves as temperature controller according to EN 14597. Application in steam boilers, pressurized hot-water plants operating without constant supervision (TRD 604) as well as any other type of heat generator. The equipment raises an alarm when the preset MIN/MAX limit value is attained. Optional current output 4-20 mA for actual value indication.

Technical Data of Temperature Sensor

Type	PN	Screwed	Connections		Pt 100	Max. temperature	Ambient temperature	Lengths available L [mm]
			TRS...	Welding stub				
TRG 5-63	40	½"	5-50/52	–	1	400 °C	100 °C	100 – 400
TRG 5-64	40	½"	5-50/52	–	2	400 °C	100 °C	100 – 400

Accuracy class A

TRG 5-65	160	–	5-50/52	form 4	1	540 °C	100 °C	115
TRG 5-66	160	–	5-50/52	form 4	1	540 °C	100 °C	140
TRG 5-67	160	–	5-50/52	form 4	1	600 °C	100 °C	200
TRG 5-68	160	–	5-50/52	form 4	1	600 °C	100 °C	200

Accuracy class A/B

Technical Data of Temperature Switches / Controllers / Indicators

Type	Outputs		Control characteristic			Mains supply Standard	Version			Performance test in acc. with DIN 3440	Adjustable temp. range	Approved	
	Switchpoint	4-20 mA	MIN	MAX	Δ T		b	c	e			TÜV	EC
TRS 5-50	1	(optional)	–	●	–	24 V DC	●	–	–	annual	0 °C – 650 °C	●	●
TRS 5-52	2	4-20 mA	●	●	–	24 V DC	●	–	–	–	0 °C – 650 °C	●	

Safety temperature limiter acc. to EN 12953

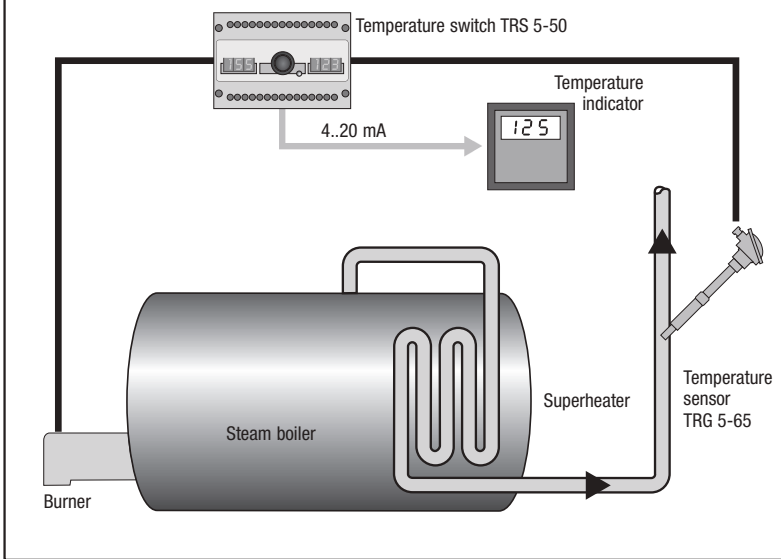

Safety temperature limiter

Equipment combination	PN	Stock code
PT 100 T < 540 °C		
TRG 5-66 L = 140 mm	160	2671712
TRS 5-50 24 V DC	–	3061141

Type approval

DIN CERTO STW/STB 1230

EG Z-IS-TAF-MUC-12-10-103881-009

SIL 3

Optional:

100-240 VAC

4-20 mA (0...650 °C)

.50

.57

Pressurized hot-water boiler acc. to TRD 604

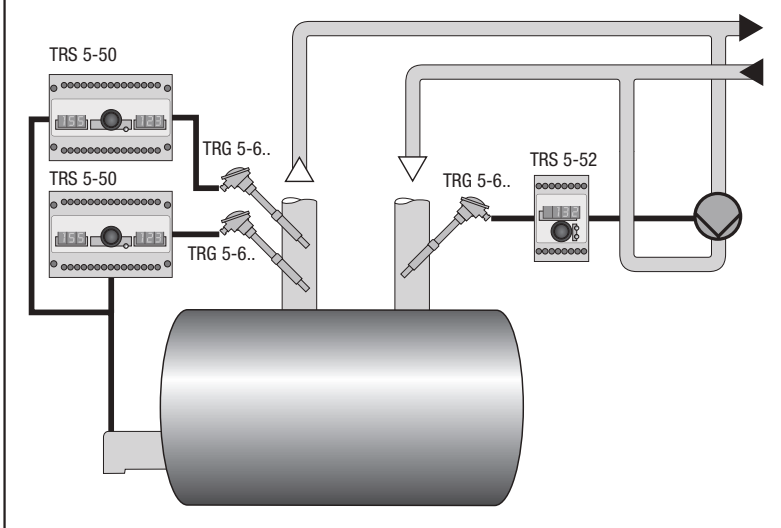

Return-temperature controller

Equipment combination	PN	Stock code
PT 100 T < 400 °C		
TRG 5-63 L = 160 mm	40	2671113
TRS 5-50 24 V DC	–	3061141
TRS 5-52 24 V DC		3061241

Type approval

DIN CERTO TW 1232

Optional:

TRS 5-50, 100-240 VAC

4-20 mA (0...650 °C)

.50

.57

For other PT see Price List.

Function

All boiler water contains some dissolved solids. These impurities are constantly concentrated due to the evaporation process, i. e. the total dissolved solids (TDS) level increases. If the TDS level were to exceed the permissible maximum stipulated by the boiler manufacturer, foaming and carry-over would take place, leading to contamination of the steam distribution system. As a result, the operational reliability of the plant will be impaired, and the boiler and steam system can be badly damaged.

Effective blowdown can be provided by use of blowdown controller in conjunction with conductivity electrode and continuous blowdown valve BAE 46-211/ball valve 510.

Deposits of fine suspended solids forming scale on the heating surfaces and settling at the bottom of the boiler are the result of residual hardness or an excessive phosphate content within the boiler water. These scale formations form a heat insulating layer, which means that the heat transfer surfaces are now subject to design pressure, but at elevated temperature, which in turn can cause deformation and even an explosion. The answer to this problem is the use of continuous blowdown timer TA 5 / 7, solenoid valve 340 and intermittent blowdown valve MPA 46 / MPA 47 / MPA 110.

Application

Steam boilers	Boiler water, feedwater and condensate monitoring acc. to TRD
District-heating plants	Condensate monitoring
Paper industry	Condensate monitoring
Pulp industry	Condensate monitoring
Catering kitchens	Condensate monitoring
Water-treatment plants	Conductivity monitoring
Dyeworks	Dyebath monitoring
Filling/bottling plants	Detection of different products
Electric boilers	Maintaining defined conductivity
Cooling towers	Continuous blowdown control
Pickling baths	Quality monitoring

Basics

Which water values must be adhered to and where can I find a specification of the demands made on boiler water monitoring through continuous and intermittent blowdown?

The requirements made on make-up, boiler and heating water are stipulated in the European Standards

EN 12952-12 (water-tube boilers) and EN 12953-10 (fire-tube boilers).

For more information refer to:

VdTÜV/AGFW Bulletins

- TCh 1452: Quick-steaming unit
- TCh 1453: Steam generator ≤ 68 bar
- TCh 1466: Hot-water generator

VGB Guideline

- VGB-R450L: Water-tube boiler

Where can I find more information on boiler water monitoring? The European Standards EN 12952-7 and EN 12953-6 (Equipment) as well as the Ordinance of Industrial Safety ("BetrSichV") and the associated Regulations for Industrial Safety TRBS 2141, part 2 will help.

Principles of Measurement

Conductivity measurement, 2-electrode system

An alternating voltage is applied to two electrode tips (polarization). The current flow is directly proportional to the specific conductivity of the fluid.

Particularly suitable for pure fluids applications up to 500 µS/cm (e.g. steam regenerators, condensate/feedwater tanks, steam generating units > PN 40 etc.).

Conductivity measurement, 4-electrode system

The 4-electrode method is used in order to improve the quality of the measuring result and to avoid polarisation. This measuring method separates the current-carrying from the voltage-carrying measuring electrodes, which means that the measurement is performed without current and therefore free of polarisation and that dirt deposits can be compensated to a large extent. Particularly well suited for boiler water with high conductivities (e.g. industrial steam boilers up to PN 40).

Temperature compensation (T° Comp)

In plants with temperatures above 25 °C the influence of temperatures on conductivity is an important factor to be considered. Due to electrolytic dissociation (desintegration of a compound in a solution) conductivity increases considerably:

Degree of dissociation $\alpha \approx 2 - 3 \text{ } \%/^{\circ}\text{C}$.

Manual temperature compensation is suitable for plants with steady service temperatures. The actual conductivity is obtained by carrying out a comparison measurement (calibration) to offset thermal errors.

Automatic temperature compensation (ATC) is ideal for plants with varying service temperatures in order to make conductivity values independent of changes in ambient temperatures. The measured and the indicated values always refer to 25 °C and are constantly compensated for changes in pressure and temperature.

Technical Data of Conductivity Electrodes

Type	PN	Connection	Max. service pressure [bar]/ saturation temperature	Integrated temp. sensor	Max. admissible ambient temp. at terminal box	Lengths supplied [mm]	TÜV approval	EC
LRGT 16-3	40	1"	32 / 238 °C	●	70 °C	200 – 1000	●	●
LRGT 16-4	40	1"	32 / 238 °C	●	70 °C	180 – 1000	●	●
LRGT 17-3	63	1"	60 / 275 °C	●	70 °C	200 – 1000	●	●
LRG 16-60	40	1"	32 / 238 °C	●	70 °C	200 – 1000	●	●
LRG 16-61	40	1"	32 / 238 °C	●	70 °C	180 – 1000	●	●
LRG 17-60	63	1"	60 / 275 °C	●	70 °C	200 – 1000	●	●
LRG 16-4	40	3/8"	32 / 238 °C	–	70 °C	100 – 1200	●	–
LRG 16-9	40	1/2"	32 / 238 °C	●	70 °C	43	●	●

Designs

- a = Field case
- b = Plug-in unit in plastic case
- c = 19" slide-in unit
- e = Case for panel mounting

Technical Data of Electronic Control Units

Type	Outputs		Main supply Standard	Protection	Design				Measuring range (recommended)	TÜV approval	EC
	switchpoints	0/4 – 20 mA			a	b	c	e			
SPECTORconnect											
LRG 16-40 / LRG 17-40	3	1	230 V	IP 40	–	●	–	–	0.5 to 10000 µS/cm (0.5 to 500 µS/cm)	●	●
LRG 16-41	3	1	230 V	IP 40	–	●	–	–	100 to 10000 µS/cm	●	●
SPECTORmodule											
LRG 16-9 / LRG 16-9	2		24 VDC	IP 40	–	●	–	–	0.5 to 10000 µS/cm	●	●
LRG 16-4 / LRG 16-9	3	1	24 VDC	IP 40	–	●	–	–	0.5 to 10000 µS/cm	●	●
LRG 16-3 / LRG 17-3	3	1	24 VDC	IP 40	–	●	–	–	0.5 to 10000 µS/cm (0.5 to 500 µS/cm)	●	●
LRG 16-3	3	1	24 VDC	IP 40	–	●	–	–	100 to 10000 µS/cm	●	●
LRG 16-4 / LRG 16-9	4	1	24 VDC	LRR IP 40 URB 50 IP 65	–	●	–	●	0.5 to 10000 µS/cm	●	●
LRG 16-1 / LRG 17-1	4	1	24 VDC	LRR IP 40 URB 50 IP 65	–	●	–	●	0.5 to 10000 µS/cm (0.5 to 500 µS/cm)	●	●
LRG 16-2	4	1	24 VDC	LRR IP 40 URB 50 IP 65	–	●	–	●	100 to 10000 µS/cm	●	●
SPECTORcompact											
LRG 16-1	–	1	24 VDC	IP 65	–	–	–	–	0.5 to 10000 µS/cm (0.5 to 500 µS/cm)	●	●
LRG 16-2	–	1	24 VDC	IP 65	–	–	–	–	100 to 10000 µS/cm	●	●
LRG 17-1	–	1	24 VDC	IP 65	–	–	–	–	0.5 to 10000 µS/cm (0.5 to 500 µS/cm)	●	●

LRG 16-60 / 17-60

The conductivity electrode LRG 16-60 / 17-60 works acc. to the conductivity measurement principle.

LRG 16-61

The conductivity electrode LRG 16-61 features 4 electrodes working according to the conductivity measurement principle.

The LRG 16-6x / 17-60 is designed for signalling the TDS value (conductivity) in electrically conductive liquids:

- Conductivity permanently within predefined control range of the electrode.

The LRG 16-6x / 17-60 is to be used in conjunction with the conductivity controller LRR 1-60 or further system components.

The conductivity data are transferred to the conductivity controller or other system components via CAN data bus.

LRR 1-60

The conductivity controller LRR 1-60 is used in conjunction with conductivity electrode LRG 16-60 / 17-60 for conductivity monitoring and control. The conductivity controller has the following functions:

- Two limits with one switchpoint each (high-level alarm, low-level alarm) or high-level alarm and intermittent blowdown program control.
- Three-position control with predefined proportional band.
- Conductivity maintained within the control band defined by preset limits.

The LRR 1-60 features an output for a standard signal 4-20 mA. The conductivity data are transferred from the electrode LRG 16-60/ LRG 17-60 to the conductivity controller via CAN data bus.

URS 60

The safety controller in conjunction with the conductivity electrode LRG 16-6x/ 17-60 forms a conductivity measuring and limiting system. The conductivity limiter has the following functions:

- Conductivity limiters switch off the heating when the max. conductivity limit is exceeded

URB

see page 104

LRGT 16-3 / LRGT 17-3

The compact system LRGT 16-3 / 17-3 features 2 electrodes working acc. to the conductivity measurement principle.

LRGT 16-4

The compact system LRGT 16-4 features 4 electrodes working acc. to the conductivity measurement principle.

The LRGT 16-x / 17-3 is designed for signalling the TDS value (conductivity) in electrically conductive liquids:

- Conductivity permanently within predefined control range of the electrode.

The LRGT 16-x / 17-3 has a conductivity transmitter integrated in the terminal box for producing a standard signal 4-20 mA.

Sitop

Power supply unit Sitop PSU/Smart serves as a 24 V DC power supply unit for the compact system LRGT 16-3 / LRGT 16-4 / LRGT 17-3.

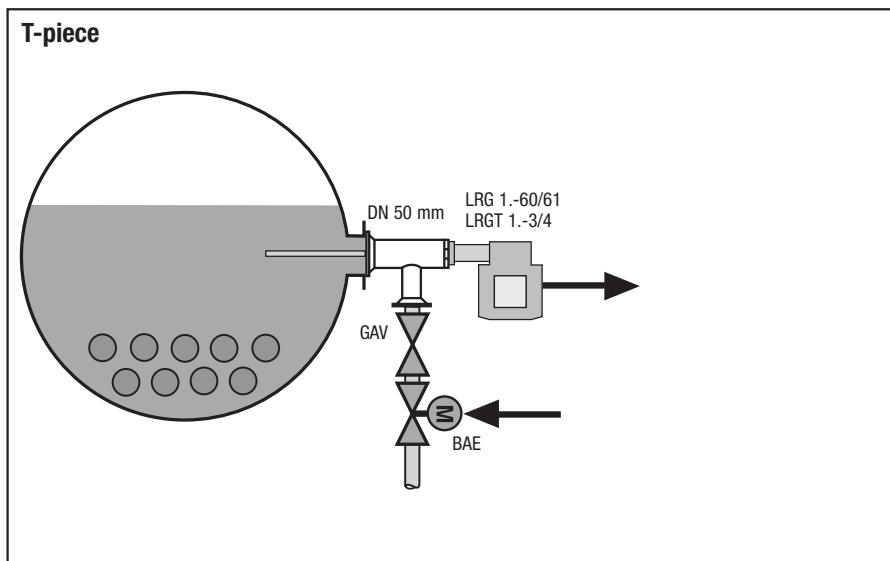
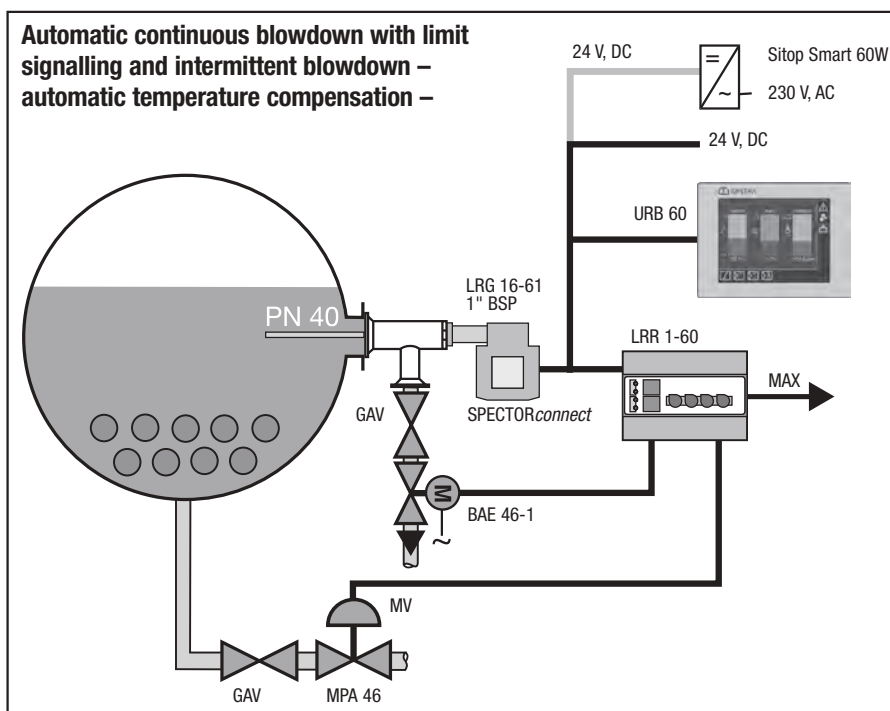

SPECTORconnect	PN	Stock code
LRG 16-61 , 600 mm	40	3791547
Tee piece 50/25 ¹⁾	40	3761502
LRR 1-60		3816041
URB 60		3386043
BAE 46-1		
< DN 15 mm	40	3891200
< DN 20 mm	40	3891400
< DN 25 mm	40	3891500
< DN 40 mm	40	3891700
< DN 50 mm	40	3891800
MPA 46		
< 6 t/h DN 25 mm	40	3661500
< 28 t/h DN 40 mm	40	3661700
Solenoid valve 340C ¼" BSP		
Strainer		
GSF 335 ½" BSP	40	440267
Reducer ½" BSP – ¼" BSP		
LRG 17-60 , 600 mm	63	3792047
Tee piece 50/25 ¹⁾		1502890
LRR 1-60		3816041
URB 60		3386043
BAE 47		
< DN 25 mm	63	3901500
< DN 40 mm	63	3901700
< DN 50 mm	63	3901800
MPA 47		
< 6 t/h DN 25 mm	63	3671500
< 28 t/h DN 40 mm	63	3671700
Solenoid valve 340C ¼" BSP		
Strainer		
GSF 335 ½" BSP		440267
Reducer ½" BSP – ¼" BSP		

¹⁾ Approval in acc. with PED 2014/68/EU, module A

Type approval: TÜV WÜL 17-007
EG BAF-MUC-12-05-103881-003



SPECTORcompact	PN	Stock code
LRGT 16-2 , 380 mm	40	3386043
Safety power supply unit PSU 100 C		3373141
LRGT 17-1 , 400 mm	63	3852044
Safety power supply unit PSU 100 C		3373141

BAE 46-3 and BAE 210 see Price List

TÜV and EC type approval only in combination with LRR 1-5.



For flanges see Price List

T-piece connector

Approved in acc. with PED 2014/68/EU PN 40

Approved in acc. with PED 2014/68/EU PN 63

Manual Compensation

LRG 16-4

Application and Purpose

The LRG 16-4 in conjunction with conductivity switch LRS or conductivity controller LRR detects the electrical conductivity of process or boiler water.

Automatic Compensation

TRG 5-6.

Application and Purpose

The TRG 5-6.. continuously detects the temperature and compensates for any temperature influence on the conductivity reading.

LRG 16-9

Application and Purpose

The LRG 16-9 detects the electrical conductivity and, by means of the integrated resistance thermometer Pt 100, the temperature of feedwater, condensate, process and boiler water.

LRS 1-50

Application and Purpose

The LRS 1-50 is a compact-design limit switch for signaling MIN and MAX limits and for on/off continuous blowdown control (valve OPEN/CLOSED) with MAX limit contact for automatic boiler blowdown in steam boilers, evaporators, pure steam generators etc. A separate resistance thermometer Pt 100 can be connected to the equipment to provide automatic temperature compensation.

LRR 1-50

Application and Purpose

The LRR 1-50 is a compact-design continuous blowdown controller for automatic 3-position continuous blowdown control (valve OPEN/OPERATION/CLOSED) with a MAX limit contact for automatic boiler blowdown in steam boilers, evaporators, pure steam generators etc. A separate resistance thermometer Pt 100 can be connected to the equipment to provide automatic temperature compensation.

Design of LRS 1-50 / LRR 1-50/51

Plastic enclosure for installation in control cabinet, with removable terminal strip. Installation via 35 mm standard rail.

LRR 1-52

Application and Purpose

The LRR 1-52 is a continuous blowdown controller for automatic 3-position continuous blowdown control (valve OPEN/OPERATION/CLOSED) with MIN and MAX limit contacts for automatic boiler blowdown in steam boilers, evaporators, pure steam generators etc. The associated operating & display unit URB is mounted in the front panel and is used for setting the parameters in the controller and viewing numerical indication and bar graphs of actual value, setpoint, value of manipulated variable and trend graphs.

Design

The continuous blowdown controller LRR is inside a plastic enclosure for installation in control cabinet and provided with a removable terminal strip. Installation via 35 mm standard rail. The operating & display unit URB is mounted in the front panel of the control cabinet.

Automatic temperature compensation

LRGT 16-3 / 17-3

Application and Purpose

The compact system LRGT 16-3 / 17-3 works according to the conductometric measuring method using two measuring electrodes and features an in-built resistance thermometer Pt 1000.

LRGT 16-4

Application and Purpose

The compact system LRGT 16-4 works according to the conductometric measuring method using four measuring electrodes. Any effects caused by polarisation or contamination are almost entirely compensated for. In addition, the equipment features an integrated resistance thermometer Pt 1000.

Both systems LRGT 1.-3 and LRGT 16-4 have an in-built conductivity transmitter that generates a standardized signal 4 – 20 mA.

LRR 1-51

Application and Purpose

The LRR 1-51 is a compact-design continuous blowdown controller for automatic 3-position blowdown control (valve OPEN/OPERATION/CLOSED) with MIN and MAX limit contacts for automatic boiler blowdown in steam boilers, evaporators, pure steam generators etc. The compact system LRGT 16-3/4 or LRGT 17-3 provides automatic temperature compensation.

LRR 1-53

Application and Purpose

The LRR 1-53 is a continuous blowdown controller for automatic 3-position blowdown control (valve OPEN/OPERATION/CLOSED) with MIN and MAX limit contacts for automatic boiler blowdown in steam boilers, evaporators, pure steam generators etc. The associated operating & display unit URB is mounted in the front panel and used for setting the parameters in the controller and viewing the numerical values and bar graphs of actual value, setpoint, value of manipulated variable and trend graphs.

Design

The continuous blowdown controller LRR is inside a plastic enclosure for installation in control cabinet and provided with a removable terminal strip. Installation via 35 mm standard rail. The operating & display unit URB is mounted in the front panel of the control cabinet.

Automatic Continuous Blowdown Control
– Automatic Temp. Compensation –
< 275 °C

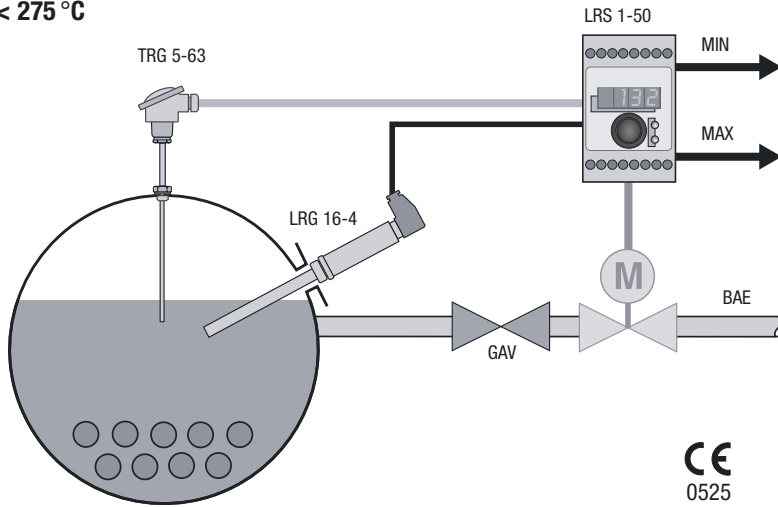

System components	PN	Stock code
LRG 16-4 400 mm, 3/8"	40	3772245
TRG 5-63 160 mm, 1/2"	40	2671113
LRS 1-50 24 V DC		3041041
BAE 46-3 DN 20, 230 V AC	40	3891403

Type approval: TÜV WÜL 17-018
EG Z-IS-TAF-MUC 12 08 103881 007

Automatic Continuous Blowdown Control
– Automatic Temp. Compensation –
< 275 °C

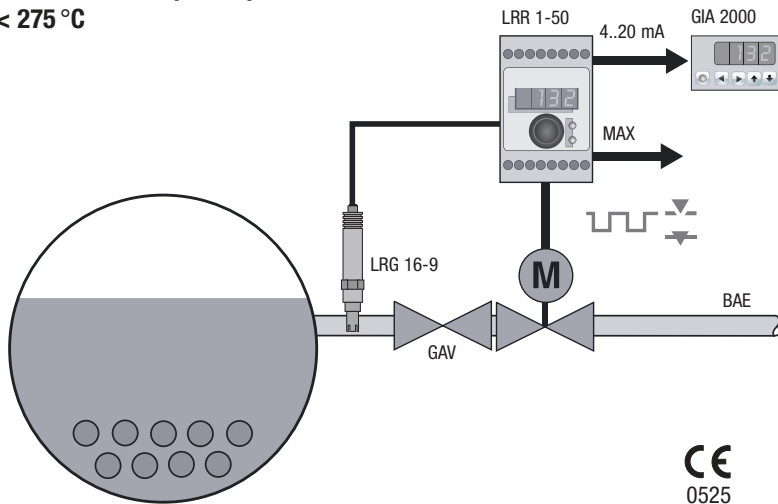

System components	PN	Stock code
LRG 16-4 400 mm, 3/8"	40	3772245
TRG 5-63 160 mm, 1/2"	40	2671113
LRG 16-9 incl. Pt100	40	3771839
Connecting cable Jack/pin 30 m		1502565
LRR 1-50 24 V DC		3041541
BAE 46-3 DN 20, 230 V AC	40	3891403
BAE 46-3 DN 20, 230 V AC	40	3891403

System components	PN	Stock code
LRGT 16-3 400 mm, 1"	40	3851045
LRGT 17-3 400 mm, 1"	63	3852045
LRGT 16-4 380 mm, 1"	40	3851545
LRR 1-51 24 V DC		3042141
BAE 46-3 DN 20, 230 V AC	40	3891403
BAE 47 DN 25, 230 V AC	63	3901500

Type approval: TÜV WÜL 17-017
EG Z-IS-TAF-MUC 12 08 103881 008

Automatic Continuous Blowdown Control
– Automatic Temp. Compensation –
incl. Intermittent Blowdown Control

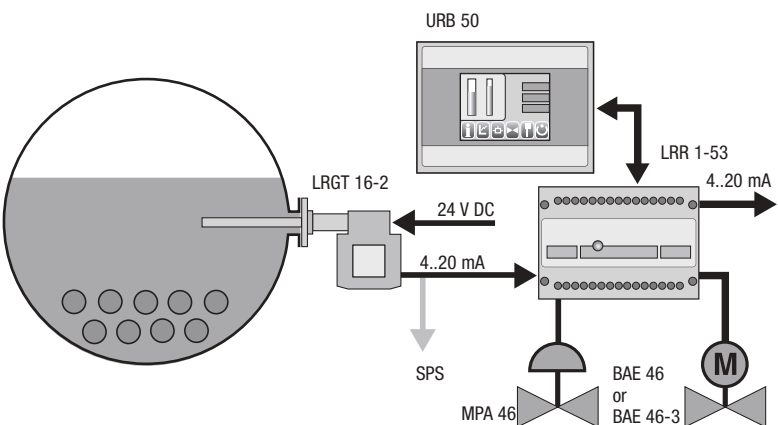

System components	PN	Stock code
LRG 16-4 400 mm, 3/8"	40	3772245
TRG 5-63 160 mm, 1/2"	40	2671113
LRR 1-52 24 V DC		3042241
BAE 46-3 DN 20, 230 V AC	40	3891403
BAE 46 DN 40, 230 V AC	40	3891700

System components	PN	Stock code
LRGT 16-1 400 mm, 1"	40	3851045
LRGT 17-1 400 mm, 1"	63	3852045
LRGT 16-2 380 mm, 1"	40	3851545
LRR 1-53 24 V DC		3042341
BAE 46-3 DN 20, 230 V AC	40	3891403
BAE 46 DN 40, 230 V AC	40	3891700
BAE 47 DN 25, 230 V AC	63	3901500

Type approval: TÜV WÜL 17-017
EG Z-IS-TAF-MUC 12 08 103881 008

If an independent valve position indicator is required, please choose a BAE actuator with feedback potentiometer and add suffix -1 to the type designation.

Automatic Temp. Compensation

LRG 16-9

Purpose and Application

The LRG 16-9 in conjunction with LRS 1-7a monitors the electrical conductivity as well as the temperature of process, condensate, boiler and feed water thanks to the integrated resistance thermometer. The system is used for limit monitoring and/or automatic continuous boiler blowdown.

Design

The conductivity electrode LRG 16-9 works with 2 electrodes and uses the electrical conductivity of water for measurement. The integrated PT 100 measures the temperature, thereby enabling automatic temperature compensation.

LRS 1-7

Purpose and Application

Used in conjunction with conductivity electrode LRG 16-9 for automatically controlled continuous boiler blowdown and/or limit monitoring in order to increase the economic viability and safety of the plant. Controlled boiler blowdown with temperature compensated indication of the electrical conductivity (TDS control). Application in steam boilers, evaporators, steam regenerators, condensate liners etc.

Design

Plastic casing for wall mounting with indicators and adjustors behind clear lid.

Automatic Continuous Blowdown Control – Automatic Temp. Compensation – > 275 °C

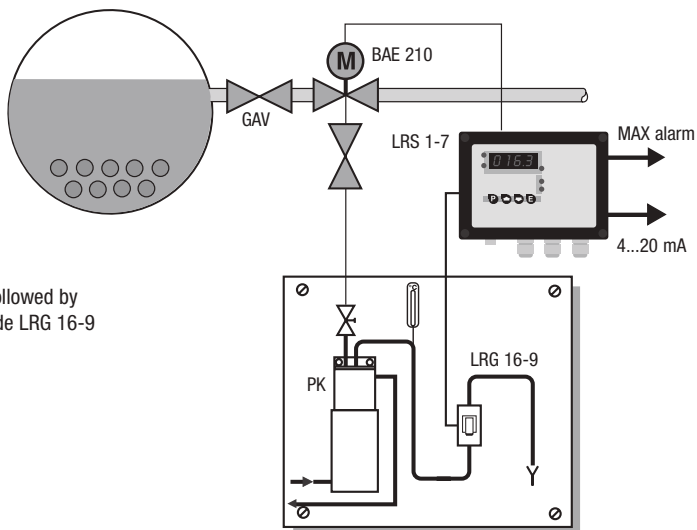

PK
Sample valve unit followed by conductivity electrode LRG 16-9

Sample valve unit > 275 °	Stock code
LRG 16-9	3771839
Connecting cable male / female 5 m	1502563
PK-250 PE2A	
LRS 1-7	3781640
BAE 210 DN 25 FI.	393150001

GAV see page 83 – 84

Type approval:
TÜV WÜL 14-014

Signalling of MAX and MIN conductivity values – automatic temperature compensation –

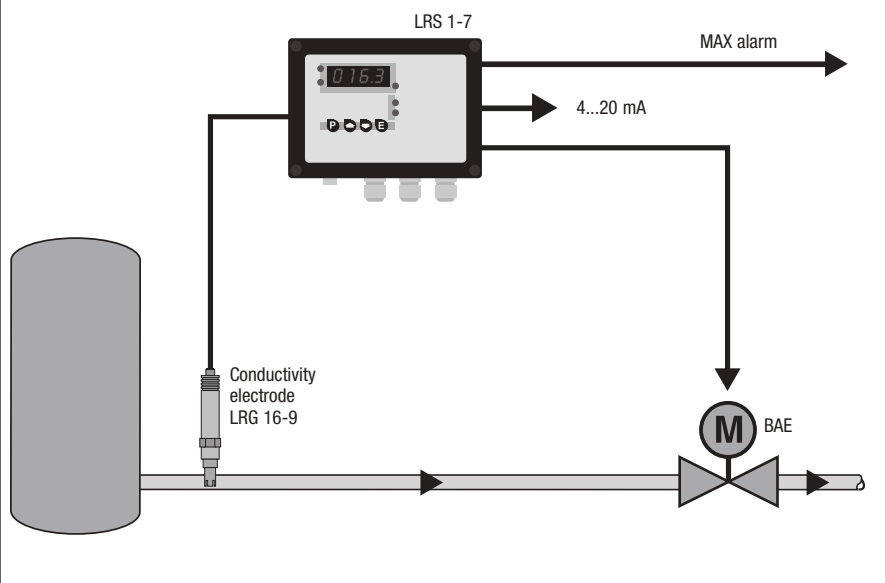

– Automatic temperature compensation

Equipment	PN	Stock code
LRG 16-9	40	3771839
Connecting cable male / female 5 m		1502563
LRS 1-7		3781640

Type approval:
TÜV WÜL 14-014

Optional LRS 1-7a
Special voltage 24 V AC

.51

Conductivity

The service case VRM 2 contains the conductivity meter GMH 3431. The GMH 3431 is equipped with a built-in measuring cell which measures the conductivity of water.

Function

The GMH 3431 is suitable for conductivities within a range from 0 to 200 mS/cm.

Design

Plastic case with foamed plastics insert.
Conductivity measuring instrument GMH 3431 with built-in measuring cell.

Conductivity and pH value

The service case VRM 3 contains the conductivity meter GMH 3431 and the pH measuring device GMH 3530.

The GMH 3431 is equipped with a built-in measuring cell which measures the conductivity of water.

The GMH 3530 is equipped with pH electrode type GE 100 BNC and Pt 100 temperature probe type GTF 401. The electrode and the probe are plugged into the equipment.

The service case contains also the handling and calibration set GAK 1400, consisting of:

- 5 orange capsules for the calibration solution pH 4.01 and a plastic bottle
- 5 green capsules for the calibration solution pH 7.01 and a plastic bottle
- 5 blue capsules for the calibration solution pH 10.01 and a plastic bottle
- 1 bottle 3mol KCL-solution
- 1 bottle pepsin cleaning agent

Function

The GMH 3431 is suitable for conductivities within a range from 0 to 200 mS/cm.

The GMH 3530 together with the pH electrode GE 100 BNC can measure pH values from 0.00 to 14.00.

The temperature probe measures temperatures between -50°C and $+250^{\circ}\text{C}$.

For pH measuring the temperature range is limited to 10°C to 50°C .

Design

Plastic case with foamed plastics insert.
Conductivity measuring instrument GMH 3431 with built-in measuring cell.
pH meas. device GMH 3530 with pH electrode GE 100 BNC and temperature probe GTF 401.
Calibration set GAK 1400.

Tee Pieces for Conductivity Electrodes

		Connections DN ²⁾	Length L approx.	Stock code
<p>DN 15 – 40 mm Boiler BAE</p>	<p>To suit electrode LRG 16-4 Material: C 22.8 / St 35.8 Pressure rating: PN 40</p>	15 / 15	118	1506435
		20 / 20	128	1506436
		25 / 25	137	1506441
		40 ¹⁾ / 40	180	1506442
<p>DN 50 mm Boiler BAE</p>	<p>To suit conductivity electrodes LRG 16-1 / LRG 16-40/41 Material: C 22.8 / St 35.8 Pressure rating: PN 40</p>	15	197	1506426
		20		1506427
		25		1506428
		40		1506429
<p>DN 50 mm Boiler BAE</p>	<p>To suit conductivity electrodes LRG 17-1 / LRG 17-40 Material: C 22.8 / St 35.8 Pressure rating: PN 63</p>	25	244	1506497
		351		

Level Pots for Conductivity Electrodes

		Connections DN ²⁾	Length L approx.	Stock code
<p>DN 15 – 40 mm Boiler BAE</p>	<p>MF 1161 STT For installing level electrodes outside the boiler LRG 16-1 / LRG 16-40 Material: C 22.8 / St 35.8 / Ø 60.3 Pressure rating: PN 40</p>	15	351	1506467
		20	353	1506468
		25	353	1506469
		40 ¹⁾	358	1506470
<p>DN 15-40 mm Boiler BAE</p>	<p>MF 1162 STT For installing level electrodes outside the boiler LRG 16-2 / LRG 16-41 Material: C 22.8 / St 35.8 / Ø 139.7 Pressure rating: PN 40</p>	15	414	1506454
		20		1506455
		25		1506456
		40 ¹⁾		1506457
<p>DN 25 mm Boiler connection BAE DN 25 mm³⁾ Electrode connection</p>	<p>MF 1171 STT To suit electrode type LRG 17-1, LRG 17-40 Material: C 22.8 / St 35.8 / Ø 60.3 Pressure rating: PN 63</p>	25	500	1506656
<p>DN 25 mm Boiler connection BAE DN 50 mm³⁾ Electrode connection</p>	<p>3MF 88.9 To suit electrode type LRG 17-1/LRG 19-1 For continuous blowdown valve BAE (automatic continuous blowdown control)</p>	PN 63 25	418	1500987
		PN 160 25		

¹⁾ Approval acc. to PED 2014/68/EU module A2

²⁾ Please state nominal size (DN) when ordering.

³⁾ Approved in acc. with PED 2014/68/EU module 6

Portable Measuring Instruments for Conductivity + pH Value

	Type	Stock code
	VRM 2 Conductivity	on request
	VRM 3 Conductivity, temperature and pH value	on request

Application

BA 46, BA 47, BA 210, BA 211, ZK 29	Valve with adjustable stage nozzle and sample valve for continuous blowdown of steam boilers and evaporators.
BAE 46, BAE 47, BAE 210, BAE 211, ZKE 29	Valve with adjustable stage nozzle, sample valve, and electric actuator for automatically controlled continuous blowdown. Especially suited for boilers operating without constant supervision (TRD 604).

Pressure/Temperature Rating According to EN 1092-1 (2013) for: 1.0460 in accordance with PED and AD 2000 or A105 according to Pressure Equipment Directive (PED).

Type	Ratings according to		Boiling point [°C] at max. pressure [bar] = T_s/p_{max}
BA 46 / BAE 46	PN 40 1.0460	EN 1092-1	238/31
	PN 40 A105	EN 1092-1	238/31
	Class 150 A105	ASME B16.34	198/14
	Class 300 A105	ASME B16.34	254/42
BA 47 / BAE 47	PN 63 1.0460	EN 1092-1	261/47
	PN 63 A105	EN 1092-1	261/47
	Class 600 A105	ASME B16.34	271/55
BA 210 / BAE 210	PN 250 1.0460	DIN 2401	348/161
BA 211 / BAE 211	PN 320 1.7335	DIN 2401	374/220
ZK 29 / ZKE 29	PN 160 1.7335	EN 1092-1	336/138

End connections

Type	Flanged EN	Flanged ASME	Socket-weld	Butt-weld
BA 46 / BAE 46	●	●	●	–
BA 47 / BAE 47	●	●	●	–

Dimensions BA 46, BAE 46 [mm]

Connections	DN	15	20	25	32	40	50
Flanged EN	L	150	150	160	180	200	230
Flanged ASME Class 150	L	150	150	160	180	230	230
Flanged ASME Class 300	L	150	150	160	180	230	230
Socket-weld	L	200	200	200	200	250	250

Dimensions BA 47, BAE 47 [mm]

Connections	DN	15	20	25	32	40	50
Flanged EN	L	–	–	190	–	220	250
Flanged ASME Class 600	L	–	–	216	–	216	250
Socket-weld	L	–	–	200	–	250	250

Dimensions BA 210, BAE 210, BA 211, BAE 211 [mm]

Connections	DN	15	20	25	32	40	50
Flanged EN	L	–	–	410	–	–	–
Flanged ASME Class 600	L	–	–	410	–	–	–
Flanged ASME Class 900/1500	L	–	–	440	–	–	–
Socket-weld	L	–	–	300	–	–	–

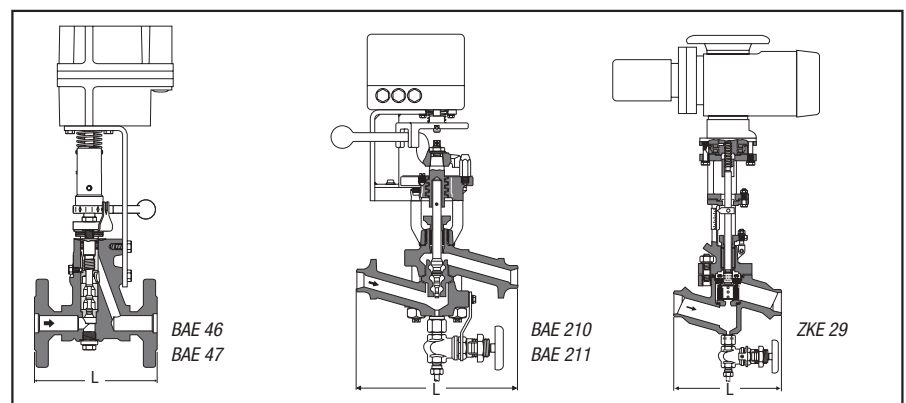
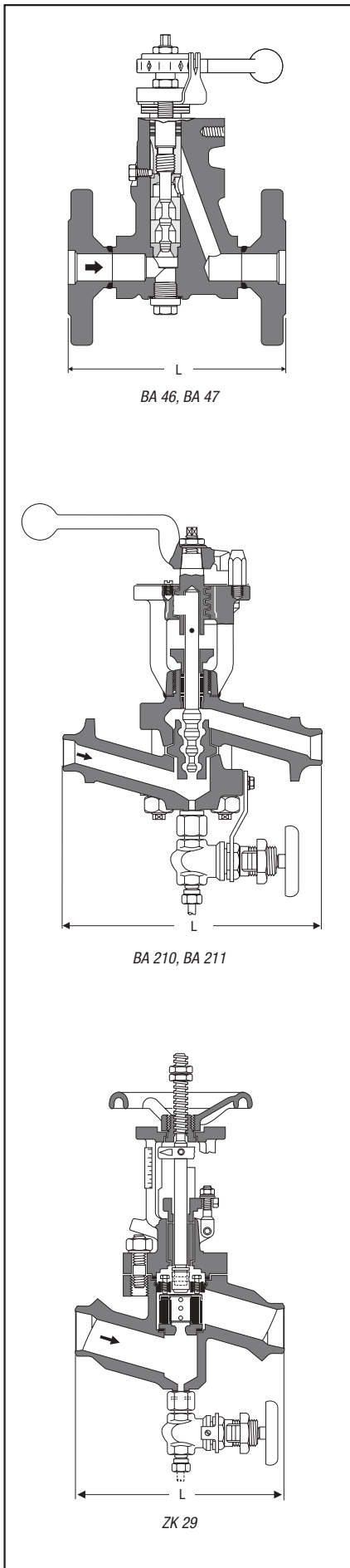

Capacity Charts

Chart 1: BA 46, BA 47, DN 15-32
BAE 46, BAE 47, DN 15-32

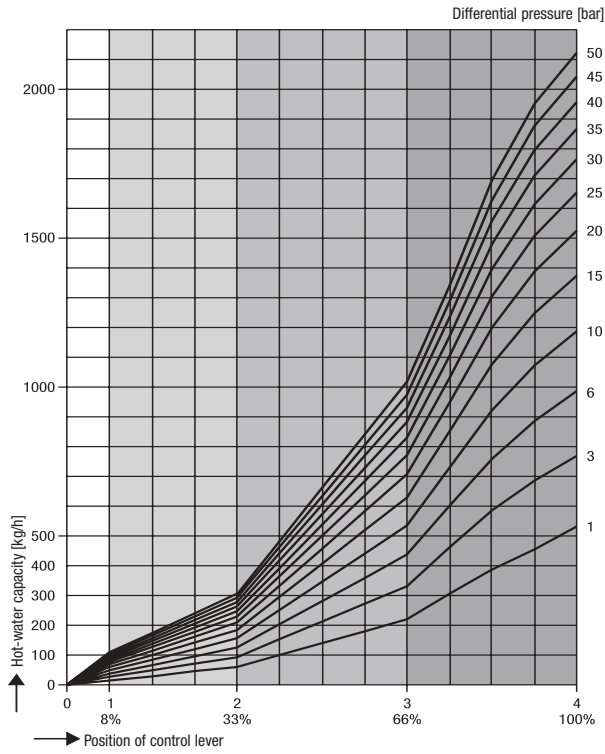

Chart 2: BA 46, BA 47, DN 40/50
BAE 46, BAE 47, DN 40/50

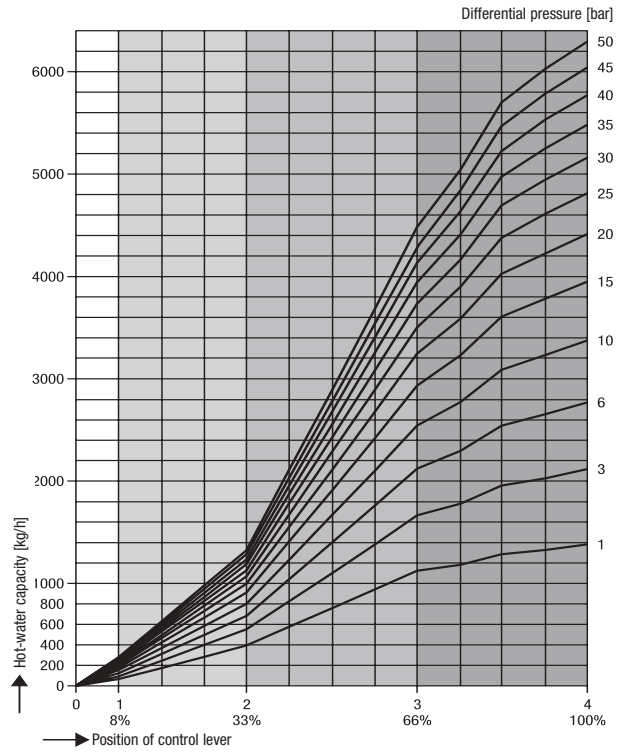

Chart 3: BA 210, BA 211
BAE 210, BAE 211

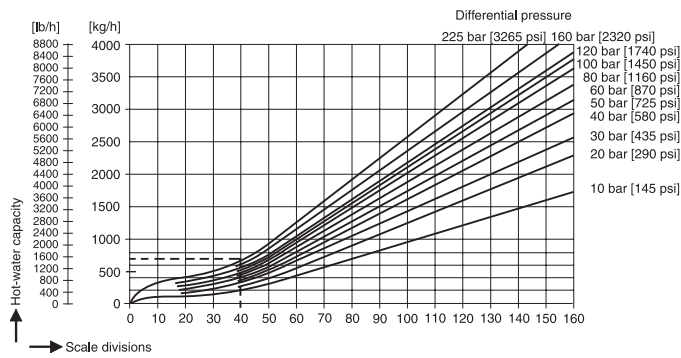
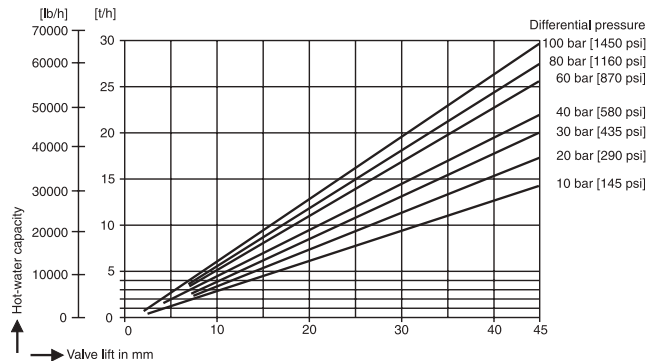
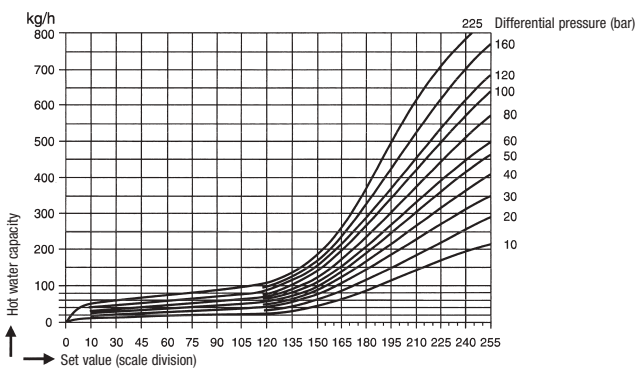

Chart 4: ZK 29
ZKE 29



1) For relatively small quantities (dotted line in chart) use 210 k or 211 k (with special stage nozzle).

Chart 5: BAE 210k, 211k



Description

A short boiler blowdown is performed by quickly opening the blowdown valve. This creates a short-term low-pressure area around the blowoff opening at the bottom of the boiler, causing a suction effect that removes accumulated sludge and sediments that have settled out in the lower part of the boiler.

The suction effect of an intermittent blowdown is only effective at the moment when the valve is being opened. For this reason the valve should only be opened for approx. 2 seconds. Longer opening periods waste boiler water.

For the closing process the design of the valve is of great importance. The closing force of the spring of the intermittent blowdown valves (M)PA is increased by the boiler pressure, which means that the valve is in a good condition for breaking up any dirt particles settled on the valve seat/plug, thus ensuring a positive shutoff.

The service life of the valve seat/plug is further increased by the pressure reduction that takes place in the radial stage nozzle installed downstream of the valve. The time interval between bottom blowdown processes can only be calculated indirectly by taking the boiler efficiency, the feedwater quality and the admissible boiler water quality into account.

Application

In steam boiler plants operating without constant supervision. Automation of intermittent blowdown by generating electric pulses to initiate a blowdown cycle via the GESTRA rapid-action intermittent blowdown valve MPA.

If space underneath the boiler is of concern, (M)PAs that can be tilted by 45° are available on request.

Controls

Type	Design	Interval time	Pulse duration sec	Mains voltage	Version		
					a	b	f
SPECTORconnect							
LRR 1-60	Continuous/intermittent blowdown controller for installation in control cabinet, with strainer and solenoid valve	1 h – 120 h	1 – 60	24 V DC	–	●	–
SPECTORmodule							
LRR 1-52 LRR 1-53	Continuous/intermittent blowdown controller for installation in control cabinet, with strainer and solenoid valve	1 h – 200 h	1 – 10	24 V DC	–	●	–
SPECTORcompact							
TA 7	Cycling timer PRS 8 integrated in solenoid valve plug, strainer, solenoid valve	30 min – 10 h	0,5 – 10	230 V / 50 Hz 24 V DC	–	–	● ●

Three-Way Solenoid Valve

Max. service pressure [bar]	Min. differential pressure [bar]	Connection	Protection
16 ¹⁾	min. 0.5	¼" BSP	IP 65

¹⁾ Max. admissible pressure for diaphragm actuator: 6 bar

Version

- a = Field case
- b = Plug-in unit in plastic case
- c = 19" slide-in unit
- e = Case for panel mounting
- f = Integrated in solenoid valve plug

Strainer

Body	Material		Connection	Mesh size [mm]
	Filter			
Gun metal Rg 5	1.4571		½" BSP	0.5

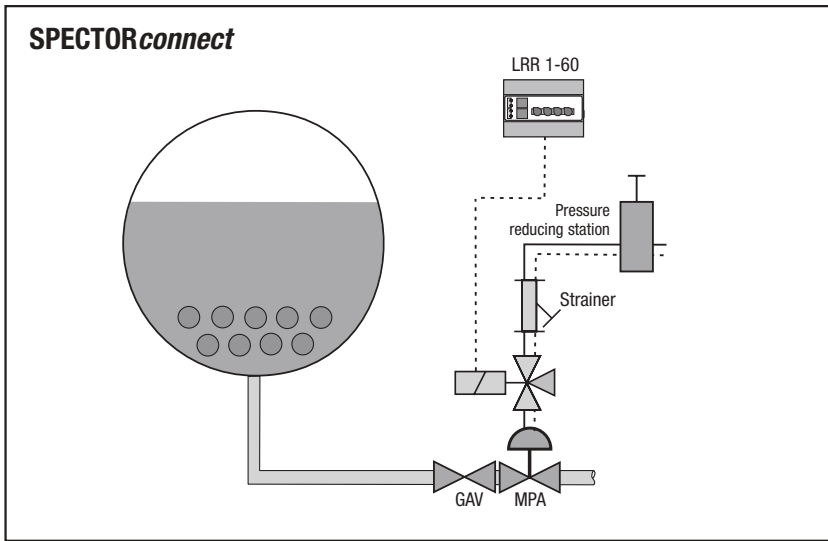

Controlled by LRR 1-60:

Type	DN	PN	Stock code
Pressure reducing station 1/4"			147545
Strainer GSF 335 1/2"			4301241
Reducer 1/2" - 1/4"			3401145
Solenoid valve 340 C 1/4", 230 V AC			050334

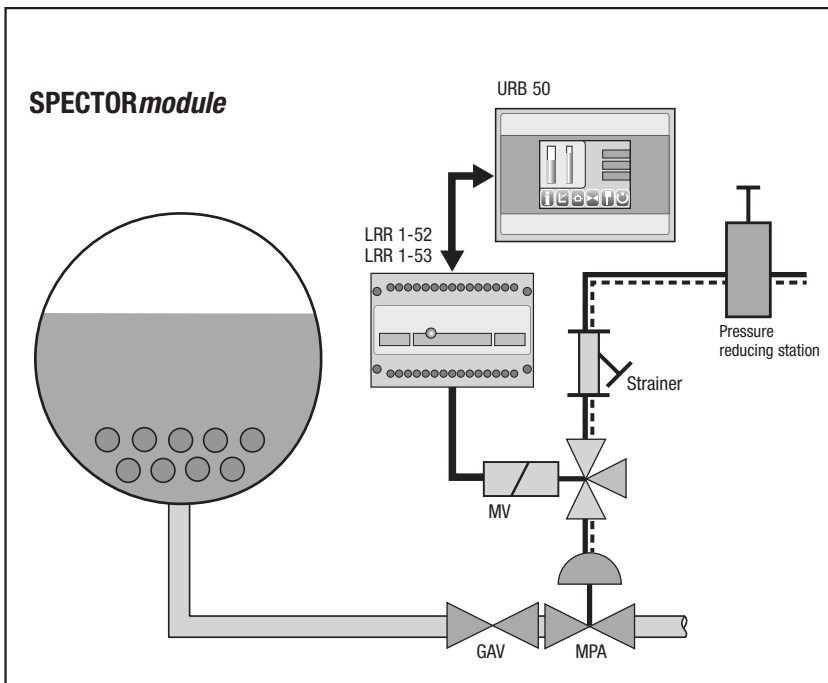

Controlled by LRR 1-52/-53:

Type	DN	PN	Stock code
Pressure reducing station 1/4"			147545
Strainer GSF 335 1/2"			4301241
Reducer 1/2" - 1/4"			3401145
Solenoid valve 340 C 1/4", 24 V DC			146247
MPA 46			
< 6 t/h	25	40	3661500
< 24 t/h	40		3661700
MPA 47			
< 6 t/h	25	63	3671500
< 24 t/h	40		3671700

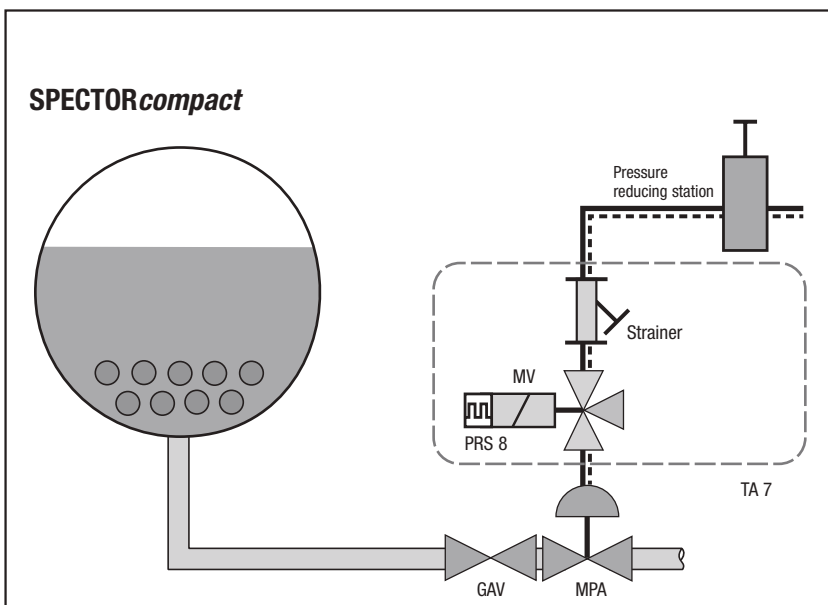

Controlled by TA 7:

Type	DN	PN	Stock code
TA 7 24 V DC			360224252
Pressure reducing station			147545
MPA 46			
< 6 t/h	25	40	3661500
< 24 t/h	40		3661700
MPA 47			
< 6 t/h	25	63	3671500
< 24 t/h	40		3671700

Application

PA 46, PA 47, PA 110	Manual intermittent blowdown of steam boilers and pressurized hot-water boilers.
MPA 46, MPA 47, MPA 110	Automatic, programme-controlled intermittent blowdown of steam boilers and waste-heat boilers. Especially suited for boilers operating without constant supervision (TRD 604).

Pressure/Temperature Rating According to EN 1092-1 (2013) for: 1.0460 in accordance with PED and AD 2000 or A105 according to Pressure Equipment Directive (PED).

Type	Ratings according to		Boiling point [°C] at max. pressure [bar] = T_g/p_{max}	Control fluid MPA...	Max. control pressure MPA...
PA 46	PN 40 1.0460	EN 1092-1	238/31	Water or compressed air	8 bar
MPA 46	PN 40 A105	EN 1092-1	238/31		
	Class 150 A105	ASME B16.34	198/14		
	Class 300 A105	ASME B16.34	254/41		
PA 47	PN 63 1.0460	EN 1092-1	261/47	Compressed air	6 bar
MPA 47	PN 63 A105	EN 1092-1	261/47		
	Class 400/600 A105	ASME B16.34	271/55		
PA 110	PN 250 1.7335	EN 1092-1	374/220	Compressed air	6 bar
MPA 110	PN 250 A182-F12	EN 1092-1	374/220		
	Class 400/600 A182-F12	ASME B16.34	300/85		
	Class 900 A182-F12	ASME B16.34	326/124		
	Class 1500 A182-F12	ASME B16.34	363/196		

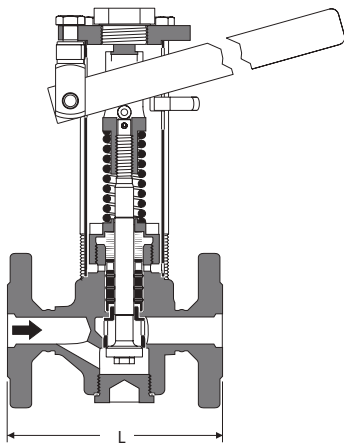

PA 46, PA 47

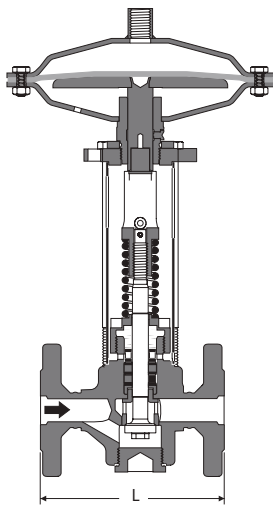

MPA 46, MPA 47

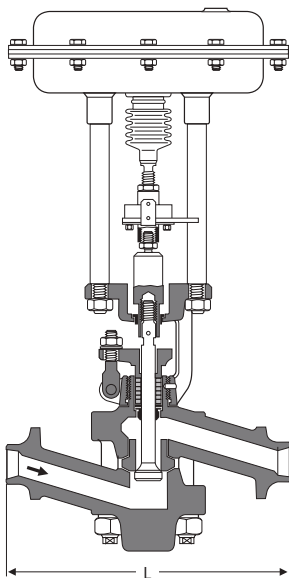

MPA 110

End Connections

Type	Flanged EN	Flanged ASME	Socket-weld	Butt-weld
PA 46, MPA 46	●	●	●	–
PA 47, MPA 47	●	●	●	–
PA 110, MPA 110	●	●	–	●

Dimensions PA 46, MPA 46 [mm]

Connection	DN	20	25	32	40	50
Flanged EN	L	150	160	180	200	230
Flanged ASME Class 150	L	150	160	180	230	230
Flanged ASME Class 300	L	150	160	180	230	230
Socket-weld	L	200	200	200	250	250

Dimensions PA 47, MPA 47 [mm]

Connection	DN	20	25	32	40	50
Flanged EN	L	–	190	–	220	250
Flanged ASME CI 600	L	–	216	–	216	250
Socket-weld	L	–	200	–	250	250

Dimensions PA 110, MPA 110 [mm]

Connection	DN	20	25	32	40	50
Flanged EN	L	–	410	–	–	–
Flanged ASME CI 600	L	–	410	–	–	–
Flanged ASME CI 900 / 1500	L	–	440	–	–	–
Butt-weld end	L	–	300	–	–	–

Capacity Charts

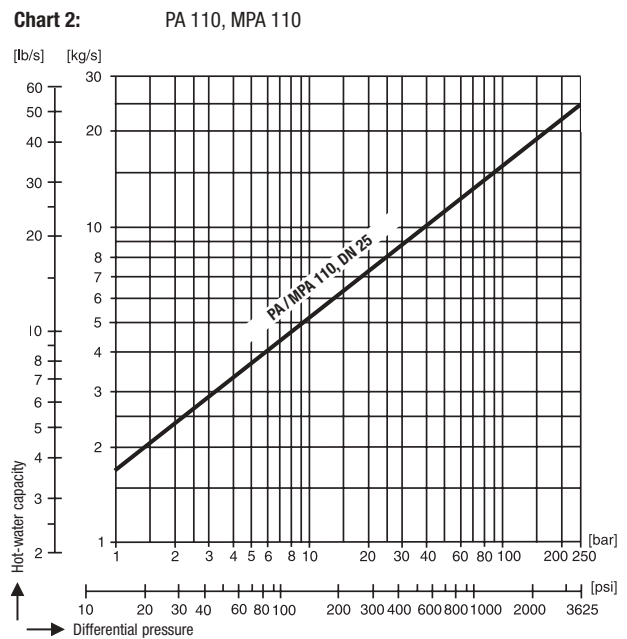
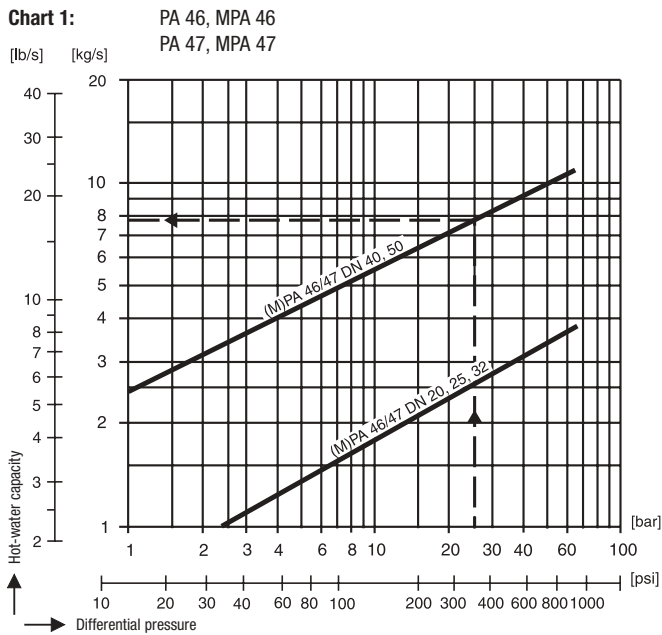

The Benefits of the New GESTRA Intermittent Blowdown Valves

- **Improved blowdown effectiveness** through integrated pressure chamber in the outlet section of the body
- **Greater tightness** through additional wiper rings between the packing seals
- **Longer service life** and availability through radial stage nozzle downstream of the valve seat
- **Insensitive to waterhammer** through absence of large body cover
- **Reduced wear** through new arrangement of the seals on the low-pressure side
- **Consistent implementation of the work safety regulations** through novel distance tube
- **Quick and easy installation** thanks to multifunction parts
- **Reduced maintenance and service effort** through additional cup springs acting on the compression spring and through the possibility of tensioning the seals from outside
- **Better checking functionally** through relief vent for leak detection from outside
- **Greater convenience** through innovative clip fastening of the hand lever PA 46/47

Liquid Monitoring – Detecting Ingress of Oil in Condensate Systems and Marine Installations

Purpose

Continuous monitoring of transparent liquids to detect any ingress of insoluble foreign matter causing turbidity, such as emulsified oils and greases. Measuring of turbidity and signal evaluation for indication, recording and control. Tripping of alarms, control valves etc.

The oil turbidity detector OR 52/ consists of a measuring sensor ORG 12/ORG 22 and the ORT 6.

Application

Condensate monitoring in steam boilers to detect any ingress of oils and greases in accordance with TRD 604, EN 12952/..53.

Monitoring of cooling water, drinking water, condensate and beverages for turbidity.

Monitoring of cooling water, drinking water, condensate and beverages for turbidity in hazardous areas – zone 1(on request).

Hot-water monitoring in district heating plants.

Filter and cooling-water monitoring on ships.

Technical Data

Type	Sensor	PN	Connection	Material	Measuring transducer ORT 6 Wall-mounting case, measuring range 0–25 ppm 2 alarm relay outputs (instantaneous/delayed) LED bar chart display 4–20 mA current output
OR 52/5	ORG 12	10	3/8"	GG 25	●
OR 52/6	ORG 22	10	3/8"	1.4580	●
OR 52/5 EX	ORG 12	10	3/8"	GG 25	●
OR 52/6 EX	ORG 22	10	3/8"	1.4580	●

Liquid Monitoring – Detecting Ingress of Acids, Alkalis, Raw Water, Dyes, etc.

Purpose

Monitoring conductive liquids for contamination by foreign matter that increases the TDS concentration; conductivity monitoring (TDS control), signalling and display.

Application

For condensate and feedwater monitoring in steam and (pressurised) hot water plants to detect ingress of acids, alkalis, raw water, dyes, etc.

Technical Data of Conductivity Electrodes

Type	PN	Conne- ction	Service pressure [bar] saturated steam temp.	Integrated temp. sensor	Ambient temperature at terminal	Lengths supplied [mm]	TÜV	GL
LRG 16-9	40	1/2"	32 / 238 °C	●	70 °C	43	●	●
LRGT 16-3	40	1"	32 / 238 °C	●	70 °C	200 / 300 / 400	●	●

Technical Data of Electronic Control Unit/Controller

Type	Outputs		Mains voltage Standard	Protection	Design				Measuring range	TÜV	GL
	switching	4 – 20 mA			a	b	c	e			
LRS 1-7a	●	●	230 V/AC	IP 65	●	–	–	–	0.5 – 10,000 µS/cm	●	●
LRS 1-50	●	–	24 V/DC	IP 20	–	●	–	–	0.5 – 10,000 µS/cm	●	–

Monitoring condensate for ingress of oils, grease, etc.

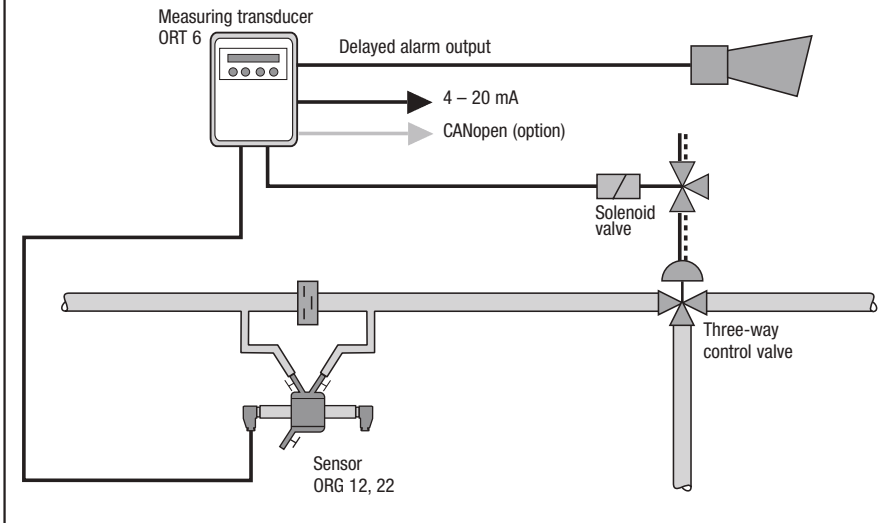

Type	Stock code
OR 52/5	4003040
OR 52/6	4003140
Pneumatic three-way control valve PN 16, DN 50 with pilot valve	1503407
Non-return valve DISCO RK 86a, SF 20 mbar PN 40, DN 50	121180182

Optional CANopen interface .60

Non-return valve see pages 38 – 49

Type approval:
TÜV WÜF 17-009



Monitoring condensate for ingress of acids, alkalis, raw water, etc.

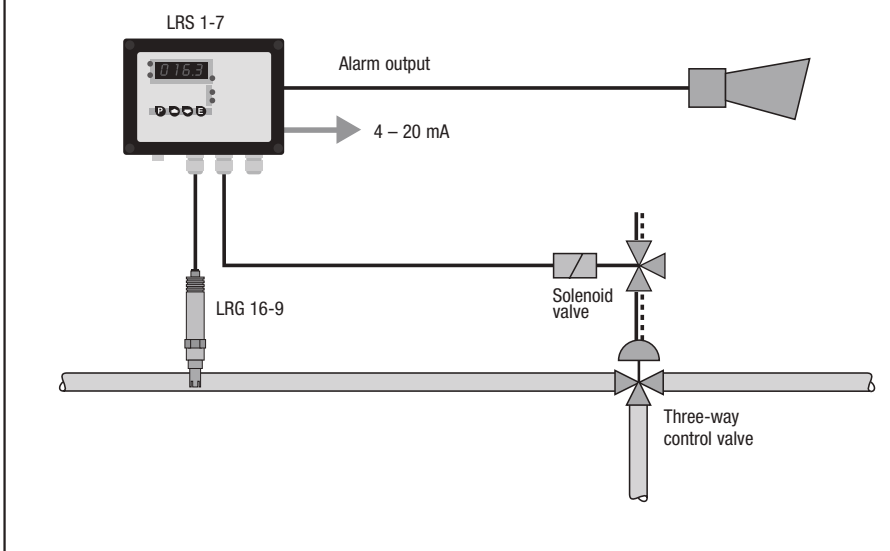

Type	Stock code
LRG 16-9	3771839
Connecting cable male / female 5 m	1502563
LRS 1-7	3781640

Pneumatic three-way control valve PN 16, DN 50 with pilot valve	1503407
---	---------

Type approval:
TÜV WÜL 14-014

Optional Special voltage 24 V AC .51

Monitoring condensate for ingress of acids, alkalis, raw water etc. in pipes that can run dry

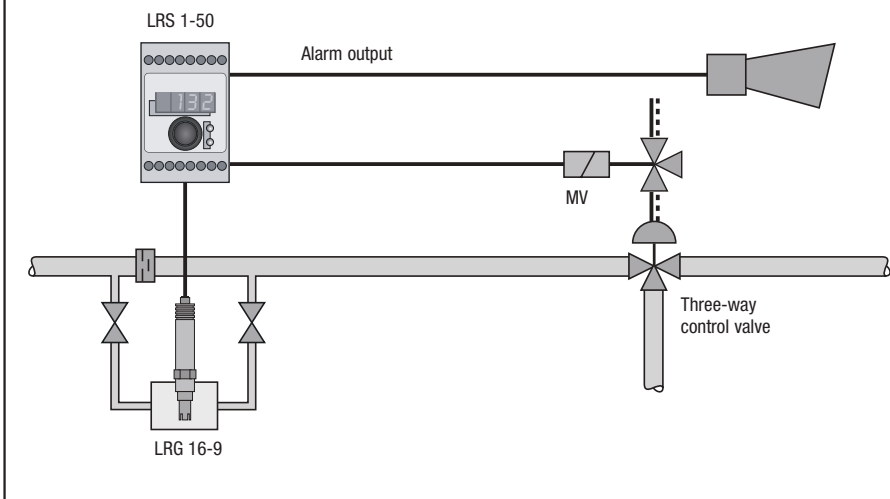

Type	Stock code
LRG 16-9 with measuring chamber, G½	377183930
LRS 1-50 24 V DC	3041041
DISCO Non-return valve RK 86a, SF 20 mbar PN 40, DN 50	121180182

Type approval:
TÜV WÜL 17-018
EG Z-IS-TAF-MUC-12-08-103881-007

Purpose and Application of Oil Detector

The oil detector ORGS 11-2 is used for monitoring cooling water to detect any ingress of oil. An alarm and control unit installed downstream of the detector will dump contaminated cooling water, thereby preventing oil contamination of the installation to be cooled. The equipment detects all low-density matter that is insoluble in water, not emulsified, and

has a lower electrical conductivity than water. Antirust oils, which emulsify in cooling water, do not trigger an alarm.

The output contact relays of the contamination detector are self-monitoring and of the normally closed type, and will therefore trigger an alarm in the event of a malfunction. Tested and approved by Germanischer Lloyd (GL).

Technical Data

Type	PN	Connection	Material
ORGS 11-2	6	Inlet E0-15-L	C 22.8
		Outlet E0-12-L/S	
		Drain E0-15-L	

Type	Stock code
ORGS 11-2	4041140

Type approval for marine applications
see page 96

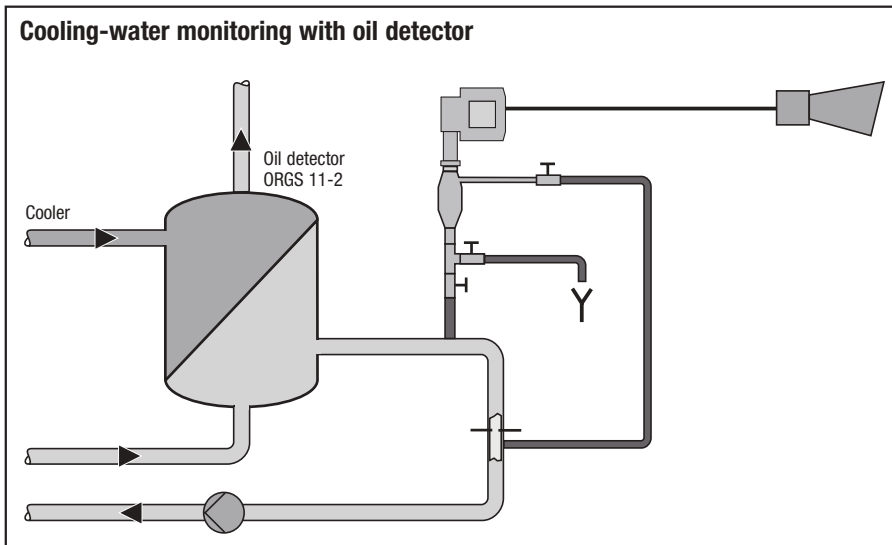

Purpose and Application Residual Hardness Control in Feedwater Systems

Softcontrol Data continuously monitors the residual hardness in a water softener system. The automatic internal calibration and self-monitoring routine ensure a high level of operational and process reliability. All analysis results and alarms are logged chronologi-

cally and stored on an integrated USB flash drive. Softcontrol Data provides continuous monitoring and logging of the statutory hardness limit of 0.05° dH. A 4 – 20 mA output signal enables integration in external PLC systems. The equipment is easy to install and works completely self-sufficiently. Apart from

exchanging the Plug&Play sensor every six to nine months no other maintenance is required. Softcontrol Data offers a clear display of information and individual adjustment options for limit values, test cycles, unit of measurements and language settings.

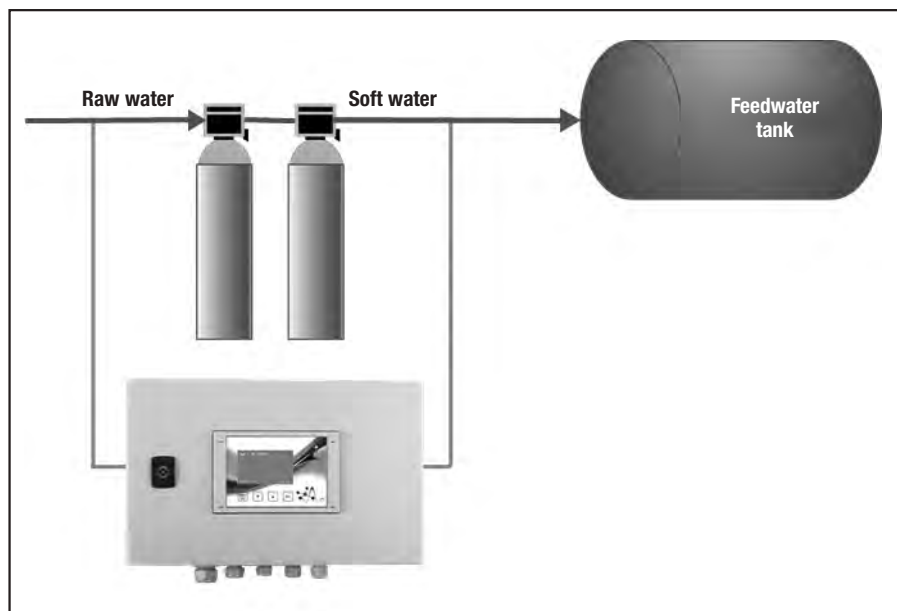

Designation	Pressure rating	Connections	Stock code
Softcontrol Data	PN 10	PA tubing OD 4 mm/ ID 2 mm	1507859

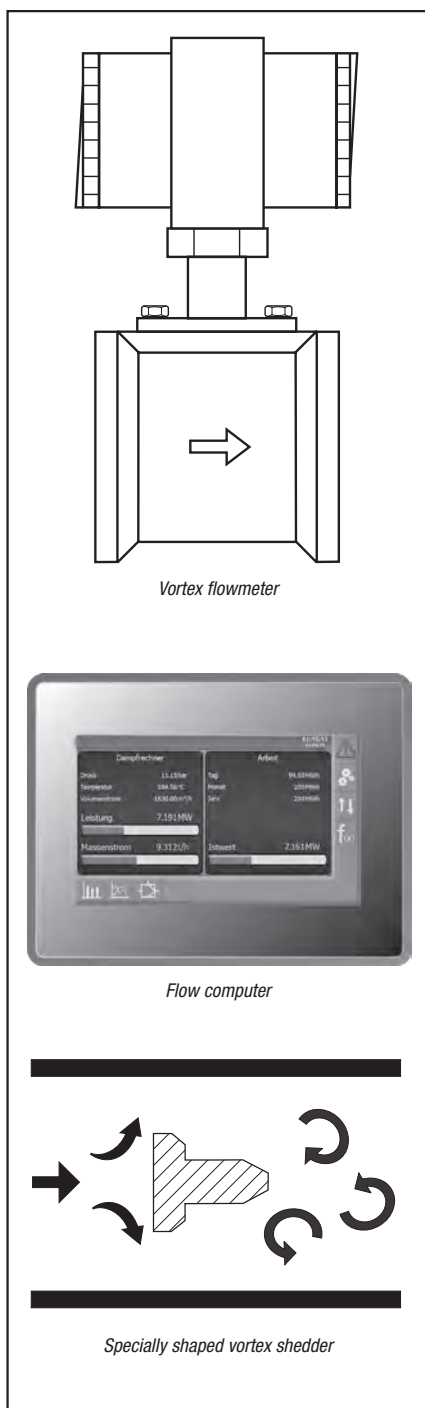

Principle of Measurement

The design is based on the Kármán vortex street principle using a body installed perpendicular to the axis of the pipe. The vortices generated in the flow stream produce pressure oscillations which are converted into electrical signals by a sensor. The output signal is then evaluated and processed in the flow computer.

Recommended steam flowrate \dot{m} in [kg/h] for Vortex flowmeter 83 *)

Absolute pressure [bar]	DN 20	DN 25	DN 40	DN 50	DN 80	DN 100	DN 150	DN 200	DN 250	DN 300
1.0	30	45	120	180	480	750	1700	3000	4500	6700
1.4	40	65	165	250	650	1030	2300	4100	6400	9200
1.6	45	72	185	290	750	1150	2600	4650	7200	10500
1.8	50	80	210	320	830	1300	2900	5200	8100	11700
2.0	60	90	230	350	920	1430	3200	5700	8900	12900
2.5	70	110	280	440	1130	1700	4000	7050	11000	15900
3.0	85	130	335	520	1340	2100	4700	8400	13000	18500
4.0	110	170	440	680	1750	2750	6200	11000	17000	24500
5.0	135	210	540	850	2170	3400	7600	13500	21000	30500
6.0	160	250	645	1000	2550	4030	9050	16100	25000	36000
9.0	235	370	745	1450	3780	5900	13300	23500	37000	53000
11.0	285	440	950	1790	4580	7150	16100	28500	44000	64000
14.0	360	560	1150	2250	5780	9030	20300	36000	56000	81000
21.0	535	830	2140	3350	8550	13400	30100	53500	83000	120000
31.0	790	1230	3150	4930	12600	19700	44300	78800	123000	177000

*) For minimum and maximum flowrates see data sheet.

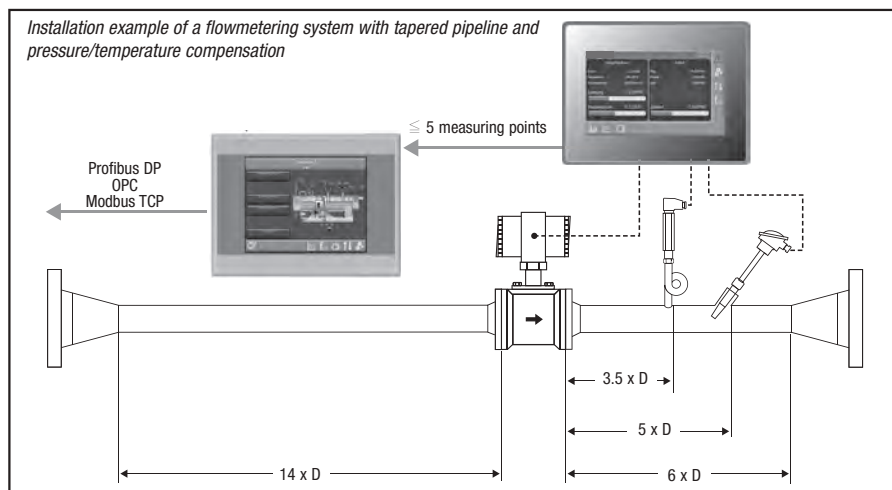

Steam-flow measurement system for constant saturated steam pressure

consisting of:
Vortex flowmeter type 84 W-U and
flow computer type SPECTORcontrol Flow

Steam-flow measurement system for fluctuating saturated steam pressure (temperature compensated)

consisting of:
Vortex flowmeter type 84 W-U,
flow computer type SPECTORcontrol Flow and
temperature sensor TRG 5-63, L = 160 mm

Steam-flow measurement system for fluctuating saturated steam pressure (pressure compensated)

consisting of:
Vortex flowmeter type 84 W-U,
flow computer type SPECTORcontrol Flow and
pressure transmitter DRT with syphon and pressure gauge.

Steam-flow measurement system for superheated steam (temperature and pressure compensated)

consisting of:
Vortex flowmeter type 84 W-U,
flow computer type SPECTORcontrol Flow,
temperature sensor TRG 5-63 and pressure transmitter DRT with syphon and pressure gauge

For up to 5 measuring points SPECTORcontrol II (a visual display & control system for viewing, calculating, monitoring and controlling) can be used.



GESTRA Special Equipment and Vessels for Heat Recovery

As a “one-stop shop” we offer special equipment and vessels for heat recovery fitted with premium-grade industrial valves and steam traps and augmented by modern control systems. Saving energy and operational safety form the foundation of our design philosophy.

CAESar Selecting & Sizing Software

Condensate flowrate, heat quantity or mass flow are the decisive factors when selecting and determining the prices of pressure vessels, heat recovery systems, desuperheaters and the like. In addition, the program can also evaluate the economic efficiency of the system, ascertain potential savings and payoff times, calculate the sizes of heating surfaces, kv values for control valves and superheat temperatures as well as determine the magnitudes of many more physical quantities.

GESTRA pressure equipment is designed, constructed and tested to PED¹⁾ 2014/68/EU and AD Bulletin 2000. Pressure equipment of category I, II, III and IV bears the CE marking. The Declaration of Conformity certifies that the equipment satisfies the applicable safety requirements of the PED.

Pressure equipment that falls within the scope of article 4 section 3 of the PED 2014/68/EU is designed and manufactured in accordance with what is recognised as sound engineering practice. This equipment will not be CE marked but must be accompanied by a Declaration of Manufacturer.

1) PED = Pressure Equipment Directive

Special Equipment and Vessels for Heat Recovery

	Page
Condensate Recovery and Return System Quick CC	150
Open-Type Condensate Recovery and Return Tank SDL (S)	151
Closed-Type Condensate Recovery and Return Tank SDL (S)	152
Steam Powered Condensate Return Tank KH	153
Steam Powered Condensate Return Tank FPS	154
Desuperheaters EK, KD	155
Steam Regenerators GRDE	156
Heat exchanger unit PWT-XPS	157
Feedwater Deaerating Plants NDR, SW, FD	158 – 159
Flash Vessels VD	160
Blowdown Receiver (Mixing Cooler) VDM	161
Condensate Dampening Pot ED	162
Air/Steam Driers and Purifiers TD/TP (Steam Separators)	163
Questionnaire for preparing offers	165 – 172



Condensate tank of rectangular design type Quick CC with high-pressure centrifugal pump(s) installed next to the tank

Application

Condensate tanks are used to collect the condensate coming from steam users or flash vessels. From the tank the condensate is pumped into the feedwater tank by a level-controlled pump, in most cases via a deaerator.

Rectangular condensate tank type Quick CC

The standard range of rectangular condensate tanks is designed for condensate flowrates of up to 8 t/h and a max. service pressure of 0.1 barg.

Tank made of steel type S235JRG2, inside: untreated, outside: anti-corrosion coating or stainless steel 1.4571 **with two condensate pumps and accessories installed next to the tank, e. g.**

bimetal dial thermometer, water-level indicator, GESTRA level electrode and control for automatic pump operation, non-return valves, shut-off valves, high-pressure centrifugal pump(s) and pressure gauge. Completely assembled and interconnected, control cabinet supplied but not mounted.

Dimensions and Weights

Pumping capacity m³/h	Delivery head mWs	Type Quick CC	Stock code 2 pumps	Weight kg	Type QuickCC	Stock code 1 pump	Weight kg
1	28	340-2-CR1-5	5201271	230	340-1-CR1-5	5201281	200
1	57	340-2-CR1-10	5201272	240	340-1-CR1-10	5201282	205
2	20	550-2-CR1-5	5201471	275	550-1-CR1-5	5201481	245
2	42	550-2-CR1-10	5201472	285	550-1-CR1-10	5201482	250
3	23	750-2-CR3-5	5201573	335	750-1-CR3-5	5201583	295
3	46	750-2-CR3-10	5201574	345	750-1-CR3-10	5201584	300
4	15	1000-2-CR3-5	5201773	390	1000-1-CR3-5	5201783	350
4	32	1000-2-CR3-10	5201774	400	1000-1-CR3-10	5201784	355
6	19	1500-2-CR5-4	5201875	485	1500-1-CR5-4	5201885	445
6	35	1500-2-CR5-7	5201876	495	1500-1-CR5-7	5201886	450
8	22	2000-2-CR10-3	5201977	610	2000-1-CR10-3	5201987	550
8	60	2000-2-CR10-7	5201978	645	2000-1-CR10-7	5201988	565

Type	Quick CC 340	Quick CC 550	Quick CC 750	Quick CC 1000	Quick CC 1500	Quick CC 2000
Volume [l]	340	550	750	1000	1500	2000
Length [mm]	1507	1657	1827	1977	2545	3075
Width [mm]	600	750	900	1000	1000	1000
Height [mm]	1532	1532	1532	1532	1532	1532

Dimensions of control cabinet: W x H x D: 400 x 500 x 210 [mm]

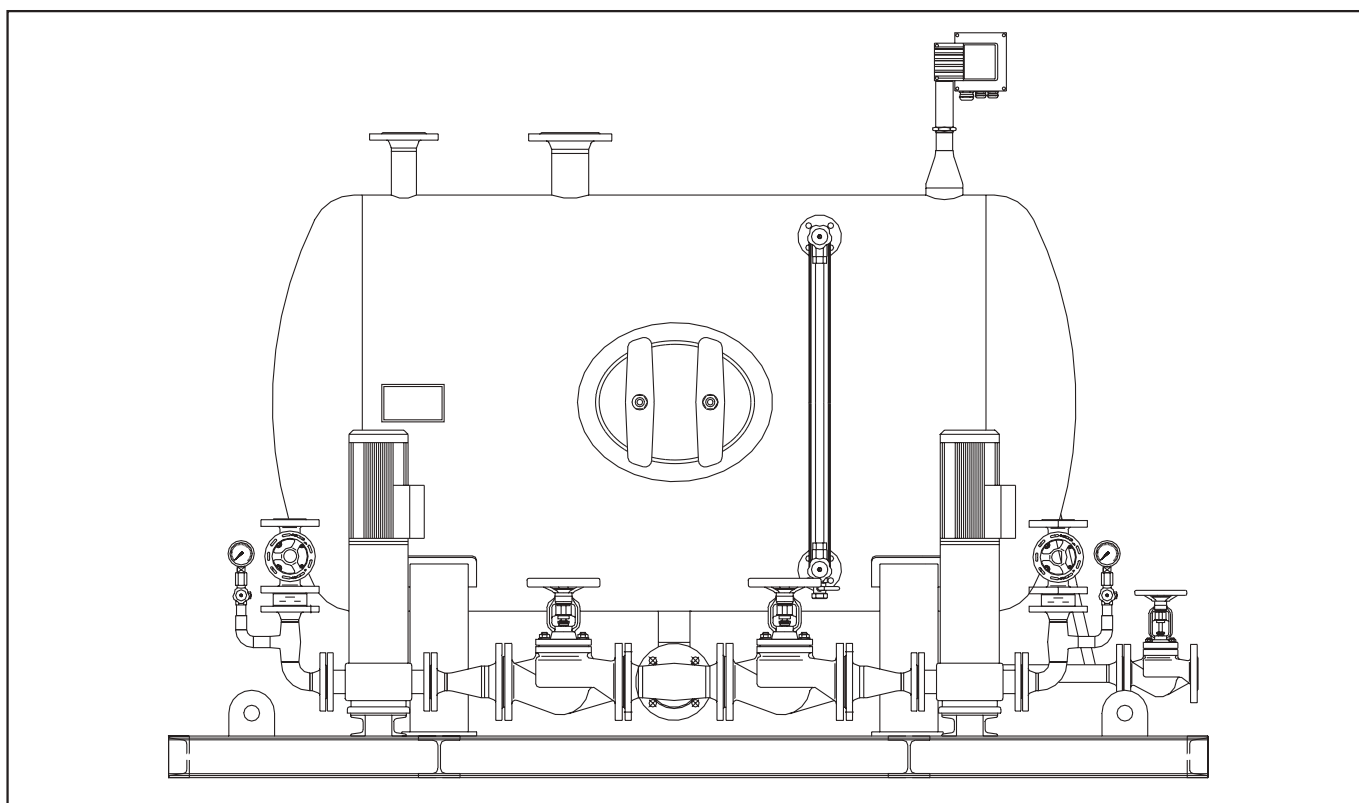

**Condensate receiver tank of cylindrical design type SDL (S)
with high-pressure centrifugal pump(s) installed next to the tank**

L = horizontal design; S = vertical design

Size	Volume [l]	Pumping capacity [m ³ /h]
I	250	1
II	390	2
III	850	4
IV	1370	6
V	2100	9
VI	2900	12
VII	3800	16
VIII	4500	20
IX	5900	25
X	6900	30

Max. condensate temperature 98°C

Application

Condensate tanks are used to collect the condensate coming from steam users or flash vessels. From the tank the condensate is pumped into the deaerator by level-controlled pumps.

Open condensate tank of cylindrical design type SDL (S)

The standard range of cylindrical condensate tanks is designed for condensate flowrates of up to 30 t/h and a max. service pressure of 0.5 bar. Condensate tanks for larger flowrates available on request.

Tanks available as horizontal or vertical design, made of steel S235JRG2, inside: untreated, outside: anti-corrosion coating. **Two high-pressure pumps and associated valves and accessories installed next to the tank: e. g.** bimetal dial thermometer, pressure gauge unit, water-level indicator, GESTRA level control and level electrode for automatic pump operation and non-return valves are part of the installation.

Other valve and tank materials available on request.
Other pumping capacities and discharge heads on request.

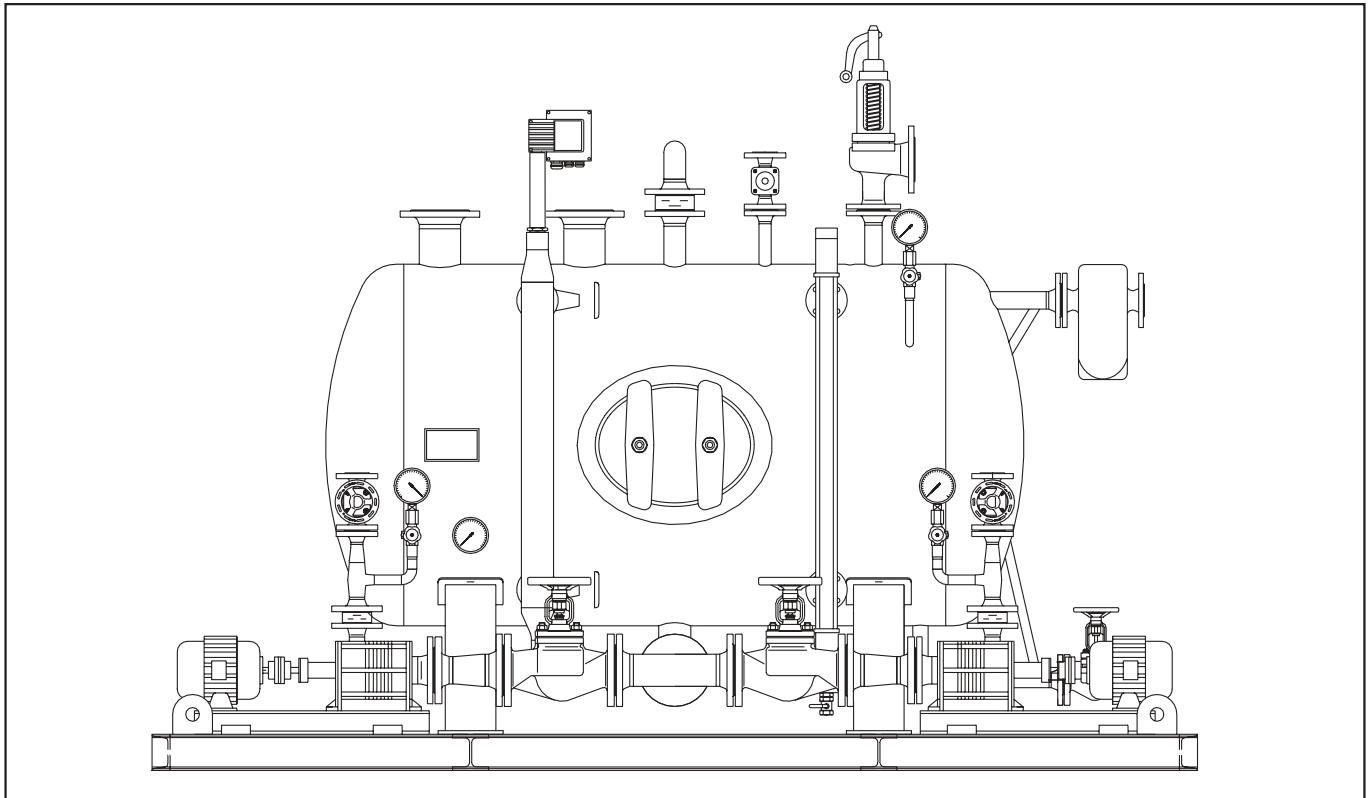

Condensate receiver tank of cylindrical design type SDL (S) with horizontal-type centrifugal pump(s) installed next to the tank

L = horizontal design; S = vertical design

Size	Volume [l]	Pumping capacity [m ³ /h]
I	250	1
II	390	2
III	850	4
IV	1370	6
V	2100	9
VI	2900	12
VII	3800	16
VIII	4500	20
IX	5900	25
X	6900	30

Application

Condensate tanks are used to collect the condensate coming from steam users or flash vessels. From the tank the condensate is pumped into the deaerator by level-controlled pumps.

Closed condensate tanks of cylindrical design type SDL (S)

The standard range of cylindrical condensate tanks is designed for condensate flowrates of up to 30 t/h and a max. service pressure of 4 bar. Condensate tanks for larger flowrates available on request.

Tanks available as horizontal or vertical design, made of steel boiler plate type P265GH, inside: untreated, outside: anti-corrosion coating. **Two horizontal-type centrifugal pumps and associated valves and accessories installed next to the tank:** e. g. bimetal dial thermometer, pressure gauge assembly, magnetically operated liquid level gauge, level electrode and control for automatic pump operation, safety device, overflow, air vent, vacuum breaker, shut-off valves and non-return valves are part of the installation.

Other valve and tank materials available on request.
Other pumping capacities and discharge heads on request.

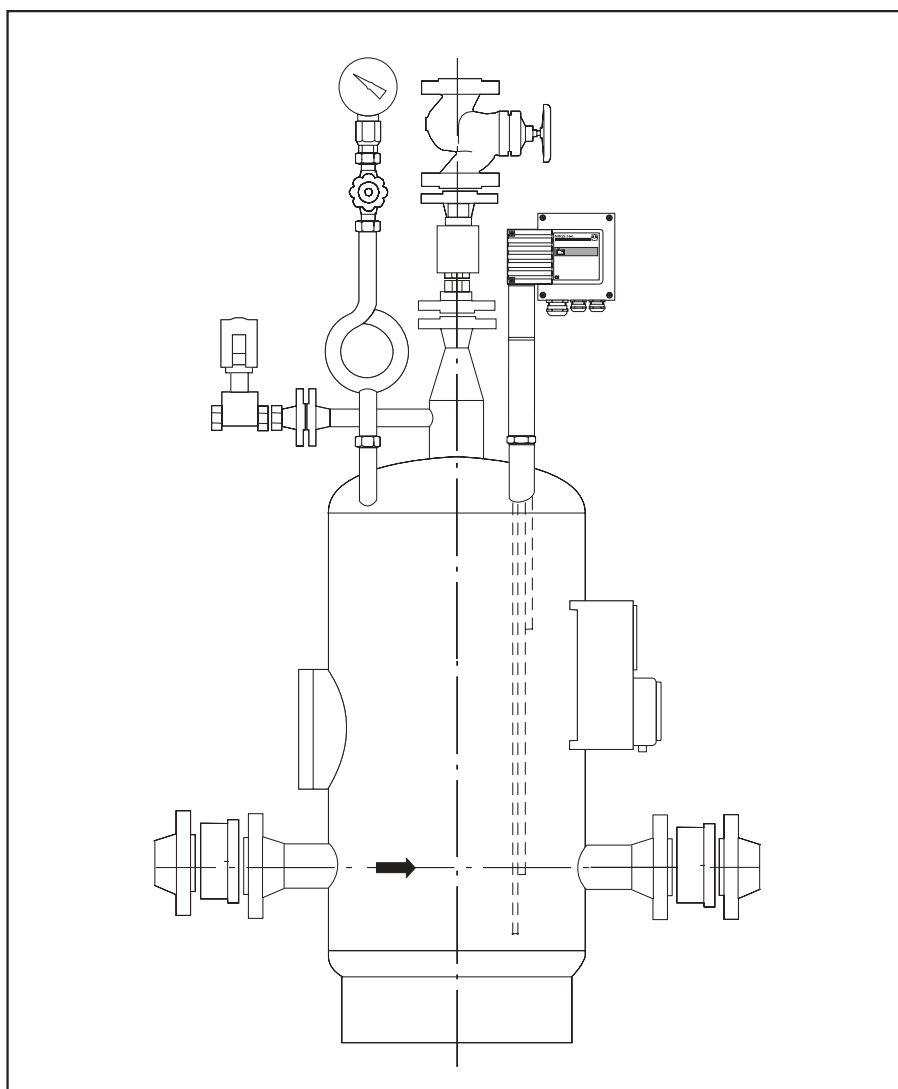

Application

Condensate tanks are used to collect the condensate from steam processors or flash vessels. From the tank the condensate is returned to the main condensate tank or deaerator with the aid of level-controlled booster steam.

Steam-powered condensate return unit KH...

The standard version is suitable for condensate flowrates of up to 10 t/h and a max. service pressure of 12 bar g.

The condensate return tank is made from steel type P265GH. Outside: anti-corrosion coating. Inside: untreated.

Associated valves and equipment such as pressure gauge assembly, solenoid valve, level electrode and control for automatic booster steam supply, non-return valves are completely assembled and interconnected.

Size	Volume [l]	Pumping capacity [m ³ /h]	Booster steam pressure	Pump capacity [bar]
KH 13-2	50	2	12	8.4
KH 13-3	75	3	12	8.4
KH 13-5	100	5	12	8.4
KH 13-10	390	10	13	8.4

Other tank and valve materials available on request.

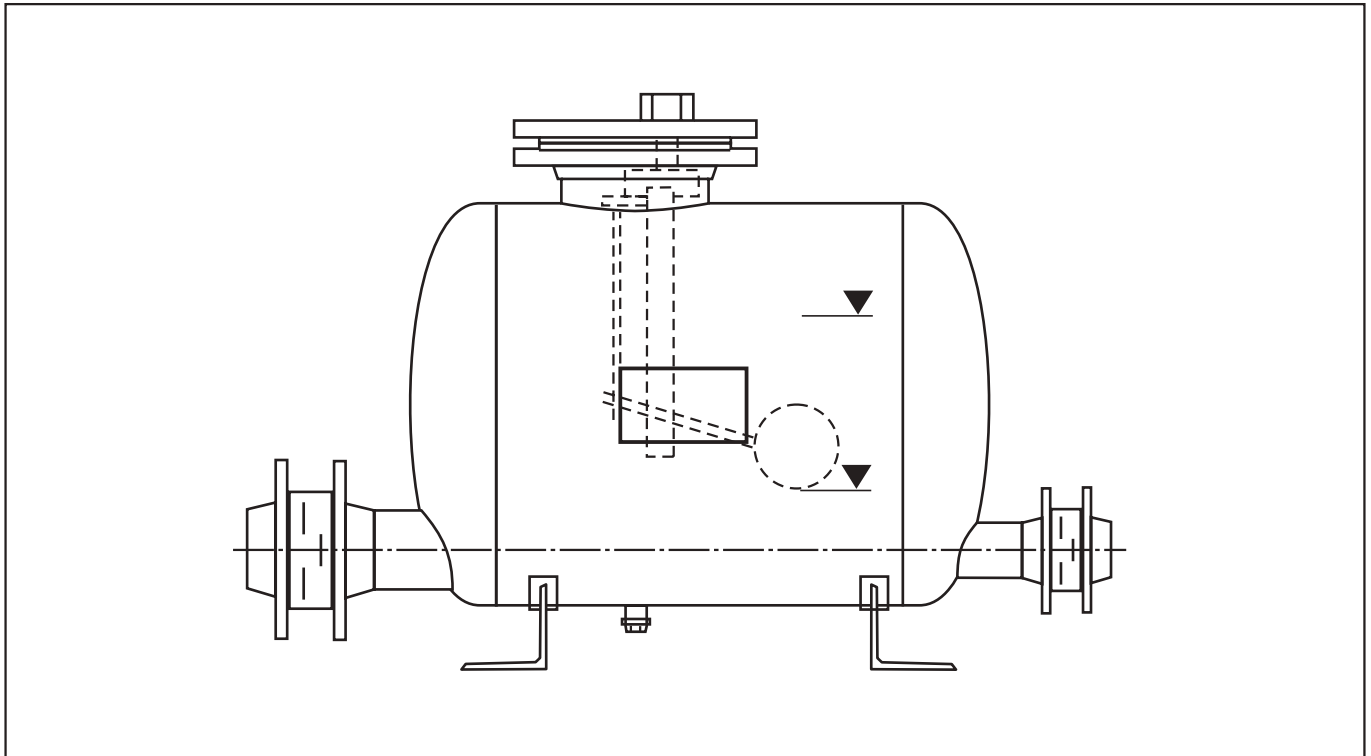

Size	Volume [l]	Booster steam pressure [barg]	Pumping capacity
FPS 11-13	45	10	up to 1000 kg/h
FPS 23-13	75	10	up to 2300 kg/h
FPS 14-13	100	10	up to 5000 kg/h

UNA 25-PS and UNA 25-PK are also available for flowrates of approx. up to 600 kg/h. For more details on the equipment see page 26 and the Price List.

Other materials for tank and valves available on request.

Application

Condensate tanks are used to collect the condensate from steam processors or flash vessels. From the tank the condensate is returned to the main condensate tank or deaerator with the aid of float-controlled booster steam.

Steam-powered condensate return unit type FPS 14...

The condensate is returned to the main condensate tank with the aid of booster steam, without electric power. The standard version of the FPS 14 is suitable for condensate flowrates of 5 t/h and a max. service pressure of 12 bar g.

The discharge capacity decreases with rising back pressure. The tank is made of steel type S235JRG2 or of P265GH. Outside: anti-corrosion coating. Inside: untreated. The non-return valves are completely assembled and interconnected, inclusive of counter-flanges, bolts and gaskets.

System 1

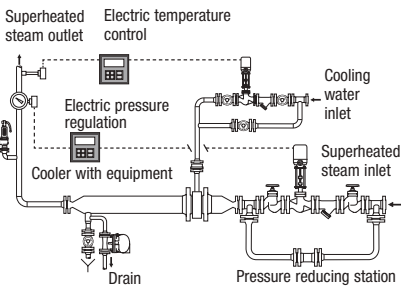

EK, Injection cooler with fixed jet orifices

System 2

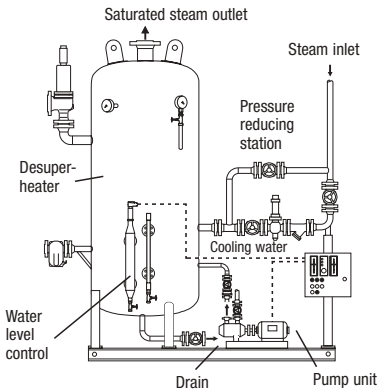

KD, Water-bath desuperheater

Application

- Heating installations in all industries
- Heating of drying calenders in the paper industry
- Heating of boiling pans in the foodstuff industry
- Heating of cable presses
- Radiant panels for hardware production in the electrical industry
- Steam moistening plants in the textile industry

System Description

System 1 Injection cooler with fixed jet orifices

The cooling water is injected through special jet orifice into the steam flow. The amount is adjusted by a control valve upstream of the desuperheater and controlled by the high differential pressure. The type and number of nozzles are dictated by the operating data. The internals of the pipe installed downstream of the equipment prevent temperature shocks at the external pipe.

System 2 Water-bath desuperheater

The heat of the superheated steam causes the cooling water/condensate to evaporate, thereby cooling the superheated steam. The steam produced is conducted through steam separating units and has a steam content of more than 98 % (i.e. less than 2 % residual moisture).

Criteria for System Selection

1. What is the ratio between minimum and maximum steam quantity in the control range?
2. What is the pressure and the temperature of the available cooling water?
3. How close must the temperature of the desuperheated steam be to that of saturated steam?

Questions concerning System Design

1. Maximum steam flow at inlet?
2. Minimum steam flow at inlet?
3. Maximum service pressure?
4. Maximum temperature at inlet?
5. Standard temperature at inlet?
6. Temperature at outlet?
7. Saturated-steam temperature?
8. Temperature of injected cooling water?
9. Injected cooling-water flow?
10. Cooling-water pressure at cooler?
11. Pump pressure?
12. Design pressure?
13. Design temperature?
14. Length of installation?

Technical Data

		System 1	System 2
Pressure rating	[bar]	28	28
Maximum temperature	[°C]	450	380
Cooling water pressure above steam pressure	[bar]	5 – 9	1
Steam flowrate	[t/h]	100	15
Steam flow ratio		1 : 5	1 : 100
Set point above saturation temperature	[K]	5	–

Higher pressures, temperatures and steam flowrates available on request.

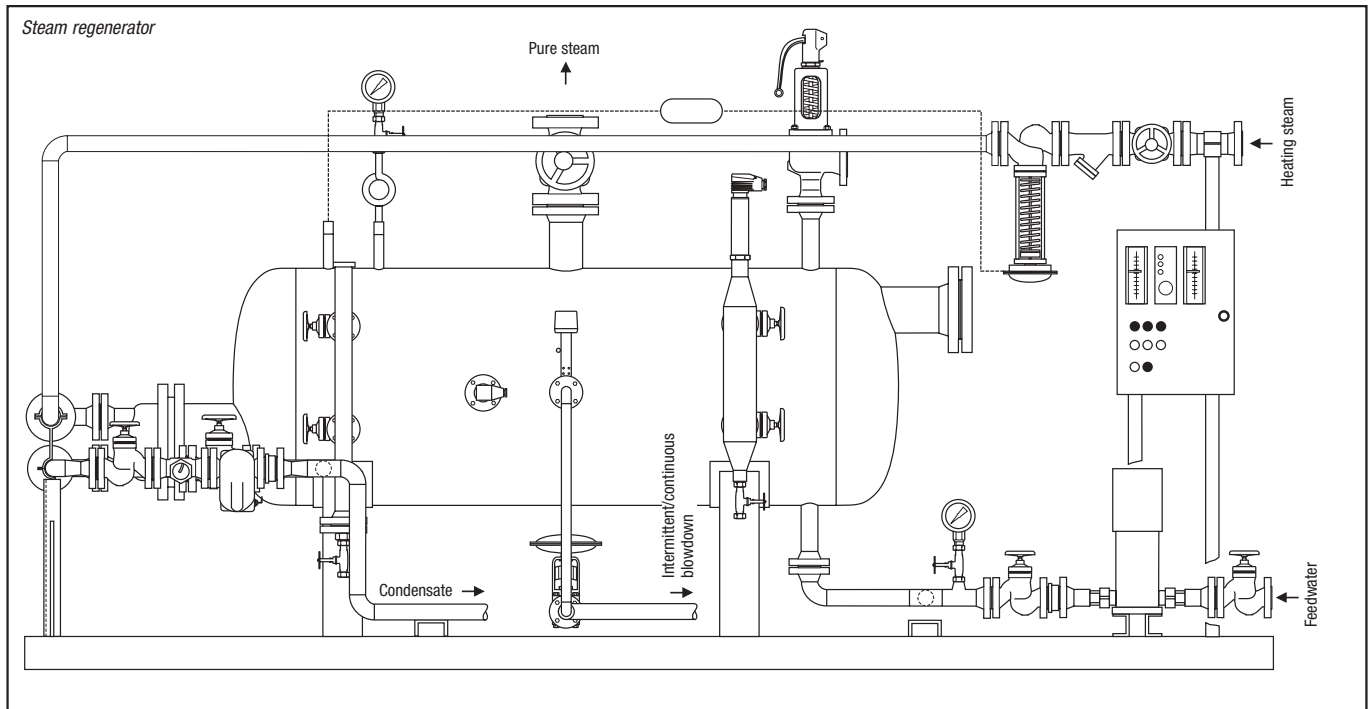

Application

Steam regenerators are used to produce saturated steam for a secondary system from steam or pressurized hot water.

Pure steam, without any contaminants that might be detrimental to health such as hydrazine, is produced.

Steam regenerators are therefore especially suited for sterilizing equipment in hospitals, steaming and drying chambers in the food-stuff industry, and for the production of distillates.

Technical Data (standard)

Service pressure	primary [bar]	28
Service temperature	primary [°C]	250
Service pressure	secondary [bar]	12
Service temperature	secondary [°C]	200
Capacity range	[kW]	5000
Feedwater quality	[µS/cm]	<= 5
Boiler water quality	[µS/cm]	<= 100

Steam regenerators for higher pressure/temperature ratings and larger capacities on request.

Standard Installation

Steam regenerators with self-acting, electric or electropneumatic heating-steam control

Compact system with manual intermittent / continuous boiler blowdown and the required basic equipment of a feedwater supply control system

Limiting conditions: Quality of feedwater ≤ 5 µS/cm, pressure of heating steam: 6 barg, pressure of pure steam: 4 barg

Type	Pure steam flowrate [kg/h]	∅ [mm]	Overall length approx. [mm]	Max. design pressure/temperature primary [bar / °C]	Max. design pressure/temperature secondary [bar / °C]
GRDE 5	300	450	3300	12/200	6/200
GRDE 6	600	500	3800	12/200	6/200
GRDE 7	1000	600	3500	12/200	6/200
GRDE 8	1200	700	4000	12/200	6/200

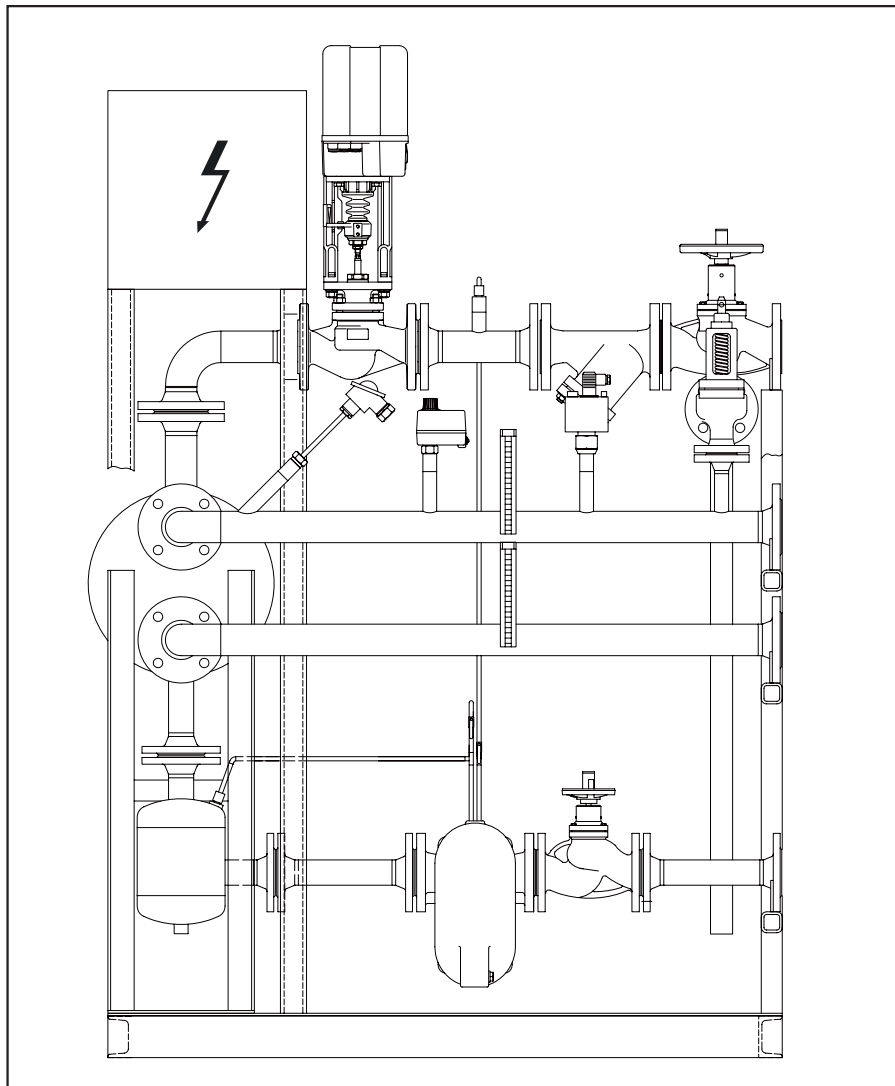

**GESTRA Heat exchanger unit
type PWT-XPS**

consists of:
plate-type heat exchanger, completely welded, in shell & plate design

equipped with:

on steam side:
shut-off valve, strainer and electrically operated control valve with safety resetting device

on condensate side:
pump steam trap, non-return valve, shut-off valve

measuring & control equipment:
safety temperature limiter, safety pressure limiter, temperature sensor, temperature controller, thermometer, pressure gauge, safety valve

The unit is completely assembled and interconnected and mounted on a stable base frame.

Auxiliary energy: 230 V, 50 Hz

Type PWT-XPS	Capacity kW	Saturated steam barg	Water °C	Capacity kW	Saturated steam barg	Water °C	Capacity kW	Saturated steam barg	Water °C
50-32 H11	160	1	70/90	300	3	70/90	500	6	70/90
50-44 H11	380	1	70/90	675	3	70/90	700	6	70/90
50-72 H11	700	1	70/90	1100	3	70/90	1400	6	70/90

Larger capacities available on request.

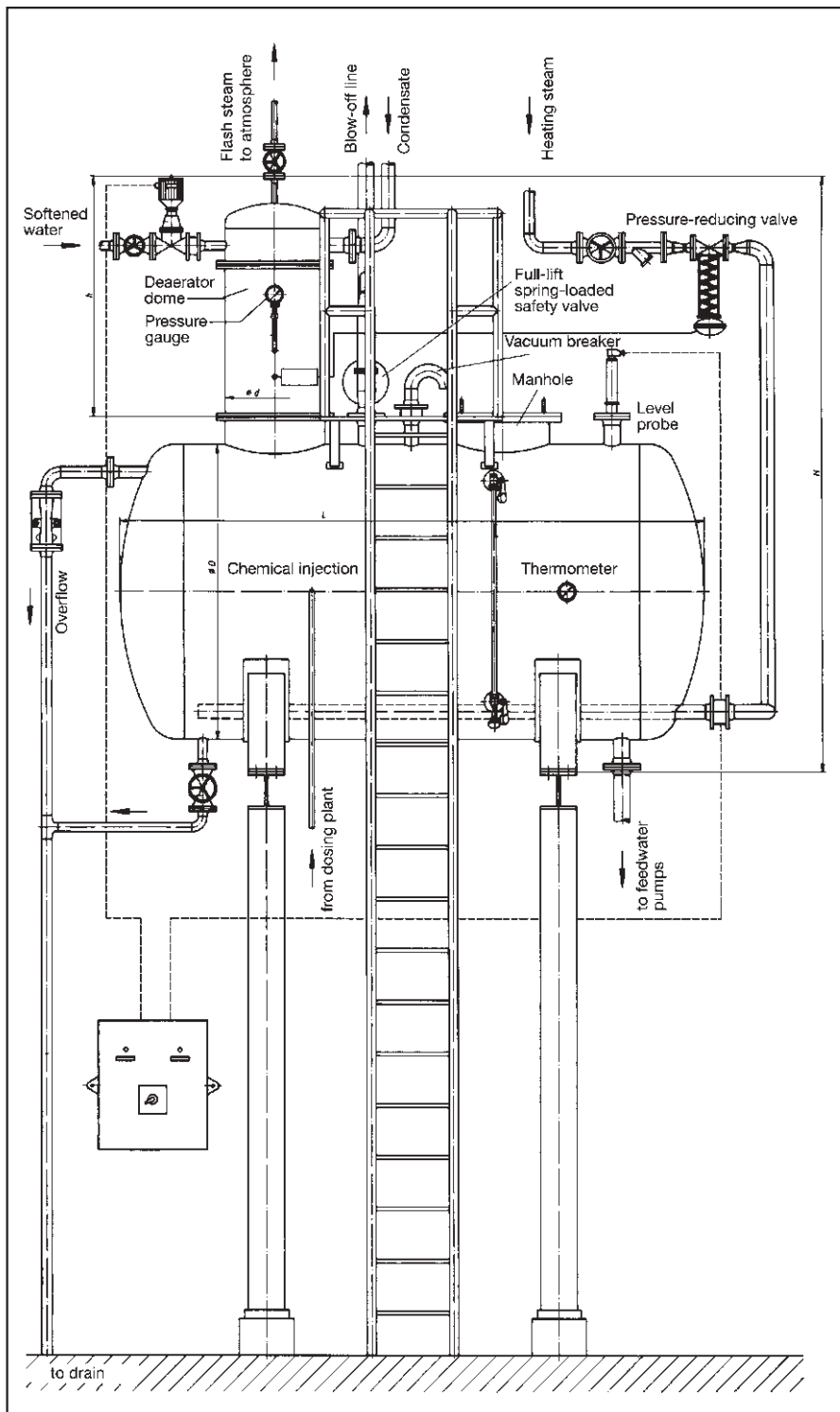

Application

To avoid corrosion damage to steam boiler plants, the content of aggressive gases, such as oxygen and carbon dioxide, in the feedwater must be as low as possible. The German Technical Supervisory Association (VdTÜV) has issued directives concerning boiler feedwater quality which are applied by German boiler manufacturers when giving a warranty on their boilers. Thermal deaeration in addition to chemical deaeration is very important for maintaining the required feedwater quality.

Recommendation:

For quality of soft water:
 Concentration of chloride approx. 50 mg/l
 Conductivity approx. 250 µS/cm

Deaerating dome NDR

Type	Capacity m³/h	∅ mm	Height approx. mm
250	0.5 – 1.6	250	1050
350	1.7 – 3.0	350	1260
450	3.1 – 5.0	450	1280
550	5.1 – 8.0	555	1300
650	8.1 – 11.0	650	1820
800	11.1 – 15.0	800	1850
900	15.1 – 19.0	900	1870
1000	19.1 – 24.0	1000	1880
1200	24.1 – 33.0	1200	2323
1400	33.1 – 40.0	1400	2473

Feedwater tank SW

Size	∅ mm	Length approx. mm	Volume of tank l
I	800	2360	1000
II	1000	2940	2000
III	1200	3050	3000
IV	1200	3550	4000
V	1600	3680	6000
VI	1600	4680	8000
VII	1600	5680	10000
VIII	2000	5000	16000
IX	2000	7850	22000
X	2500	7050	30000
XI	2500	9100	40000

Technical Data (standard)

Max. service pressure	Max. service temperature	Capacity range	Materials (DIN reference)	Residual oxygen
0.5 bar	111 °C	0.5 – 24 m³/h	S235JRG2 1.4571	< 0.02 mg/l

Higher capacities and pressures on request

The base support, access ladder and operating platform are not part of the GESTRA AG product range.

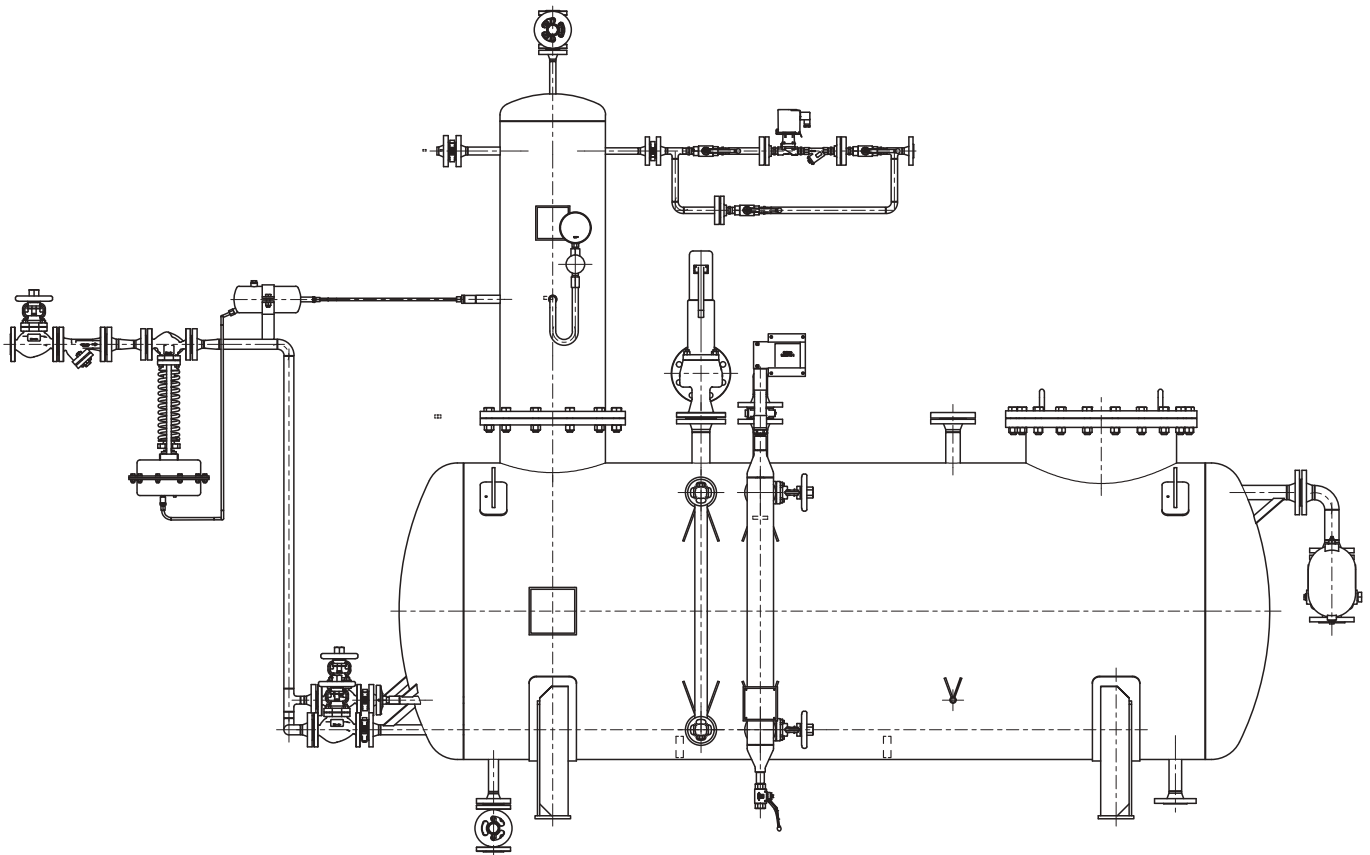

Consisting of:

Deaerator dome NDR, completely of stainless steel 1.4571, wet deck surface permanently welded
 surface treatment: pickled and passivated
 feedwater tank SW, material: S235JRG2
 surface treatment: anti-rust coating outside, untreated inside

Operating conditions:

Condensate approx. 70 %, make up water approx. 30 %
 heating steam pressure: 5 – 10 barg, operating pressure: 0.3 barg
 admissible service pressure: 0.5 barg, admissible service temperature: 111 °C
 Manufactured and tested in accordance with PED 2014/68/EU and AD 2000 Bulletin, conformity assessment: paragraph 4, section 3
 Without official acceptance inspection but with factory pressure test
 If operated properly, the residual oxygen value O₂ will be below 0.02 mg/l and carbon dioxide CO₂ will no longer be detectable.

Supplied with:

Basic equipment for the feedwater deaerator, water level control
 Heating steam control (mechanical or electropneumatic)

Base, access ladder and operator platform are not included in our product range.

Type	Service pressure	Service temperature	Capacity	Residual oxygen
FD-2m / FD-2p	0.5 barg	111 °C	1.0 - 2.0 m ³ /h	< 0.02 mg/l
FD-4m / FD-4p			2.1 - 4.0 m ³ /h	
FD-6m / FD-6p			4.1 - 6.0 m ³ /h	
FD-8m /FD-8p			6.1 - 8.0 m ³ /h	
FD-10m /FD-10p			8.1 - 10.0 m ³ /h	

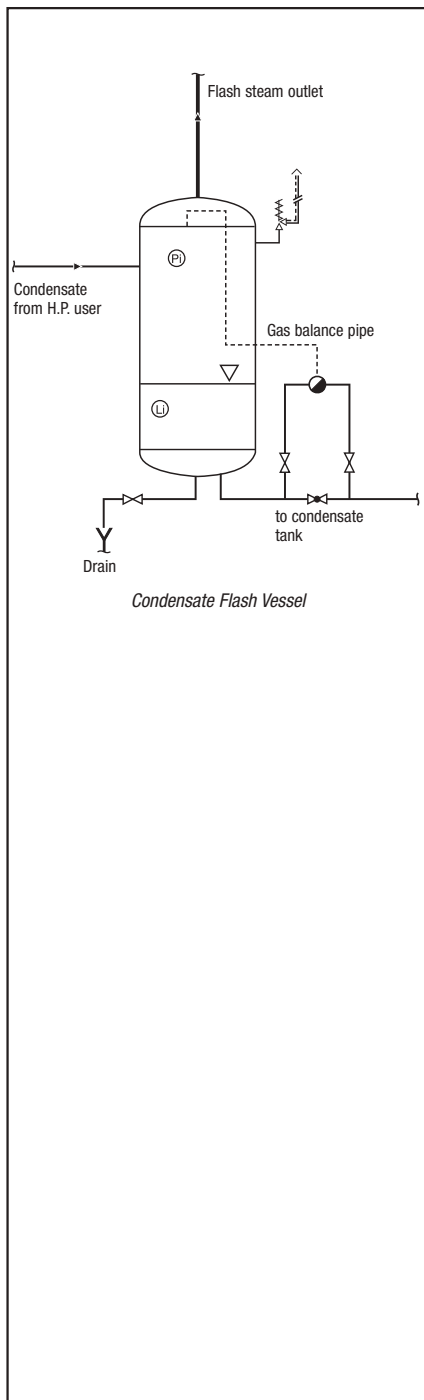

Application

Condensate flash vessel

Condensate flash vessels can be used in all steam plants where condensate from steam consumers is reduced to a lower pressure. This pressure drop constitutes a change of the energy content that causes some of the condensate to revaporize and form flash steam.

In the flash vessel the flash steam is separated from the water, and then fed into a low-pressure steam system. The condensate remaining in the flash vessel is discharged into a condensate tank.

Blowdown flash vessel

Blowdown flash vessels are used if the flash steam formed downstream of continuous blowdown valves is to be utilized.

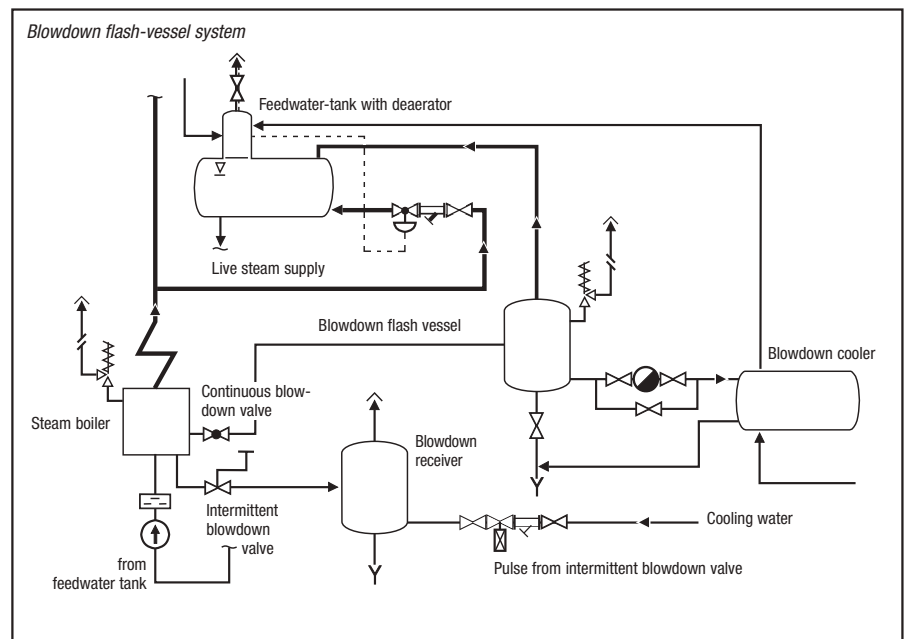

Technical Data

Type	Service pressure [bar]	Service temperature [°C]	Condensate flowrate [t/h]	Volume [l]	Material (DIN reference)
VD	0.5 – 12	111 – 250	1.2 – 40	50 – 1400	S235JRG2 P265GH
VD 45	28	250	0.2 – 1.2	15	P265GH GGG-40.3

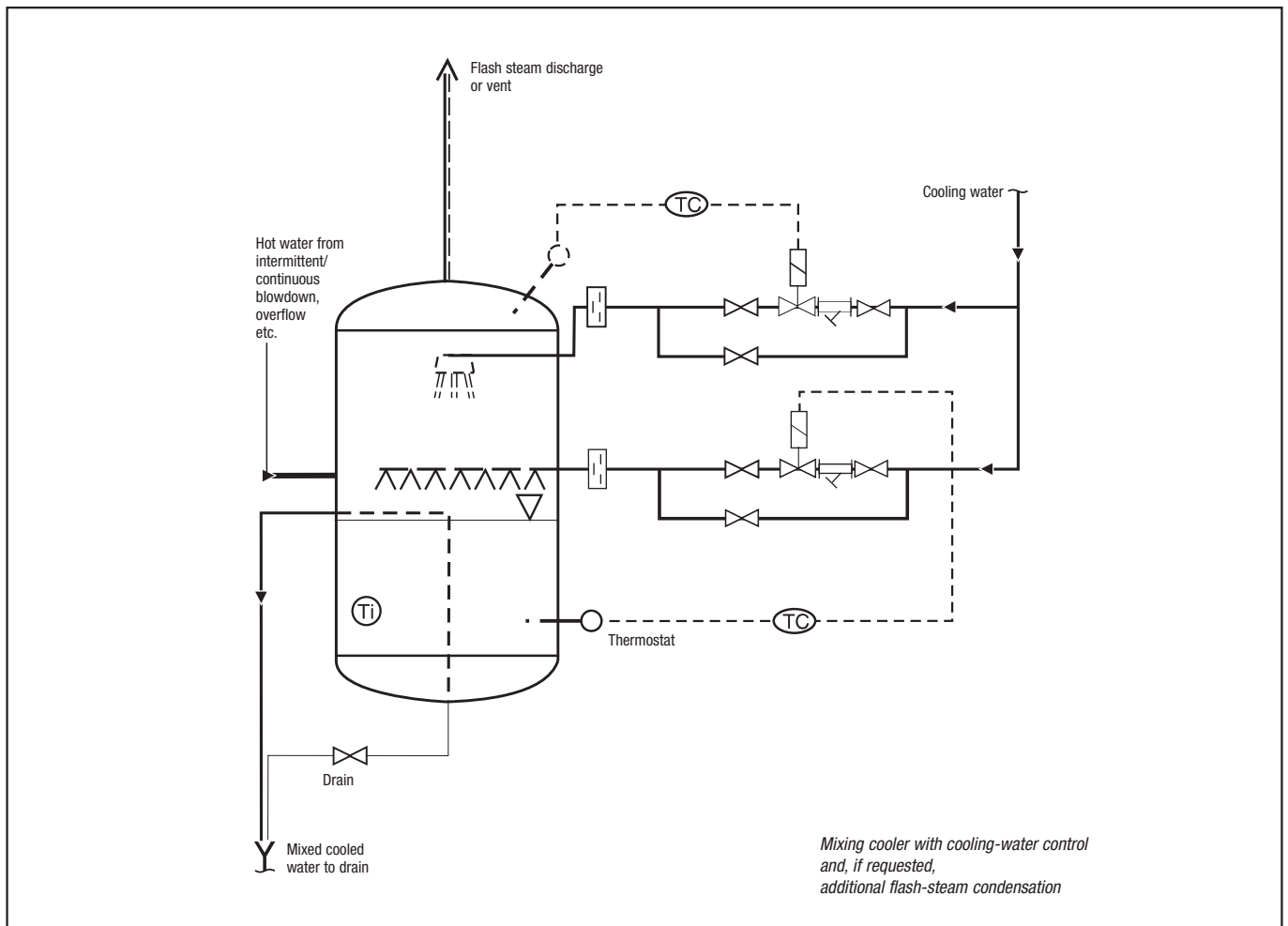

Technical Data

Max. service pressure	Max. temperature	Capacity range	Material
0.5 bar	111 °C	up to 15 t/h	S235JRG2 (RSt 37-2)
			P265GH (H II)
			1.4541
			1.4571

Description

Mixing coolers are blowdown receivers that cool hot waste water that can no longer be used for heat recovery and therefore is discharged into pits, drains or sewage systems.

Application

- Process plants where contaminated, hot waste water is being formed.
- Steam boiler plants where the blowdown is cooled with untreated water.
- Mixing coolers for vapours.

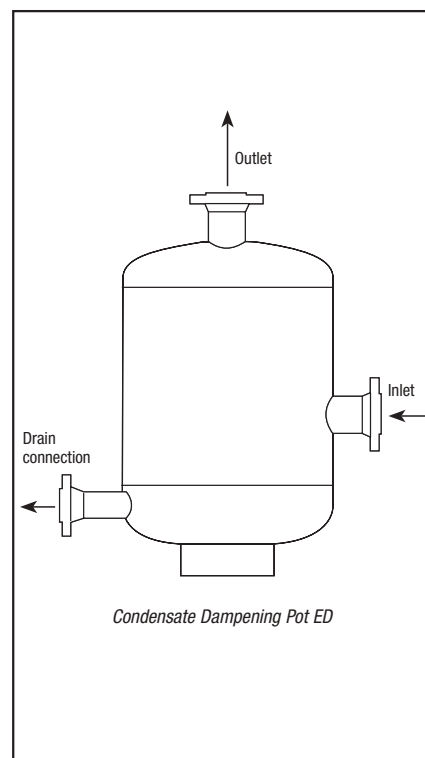
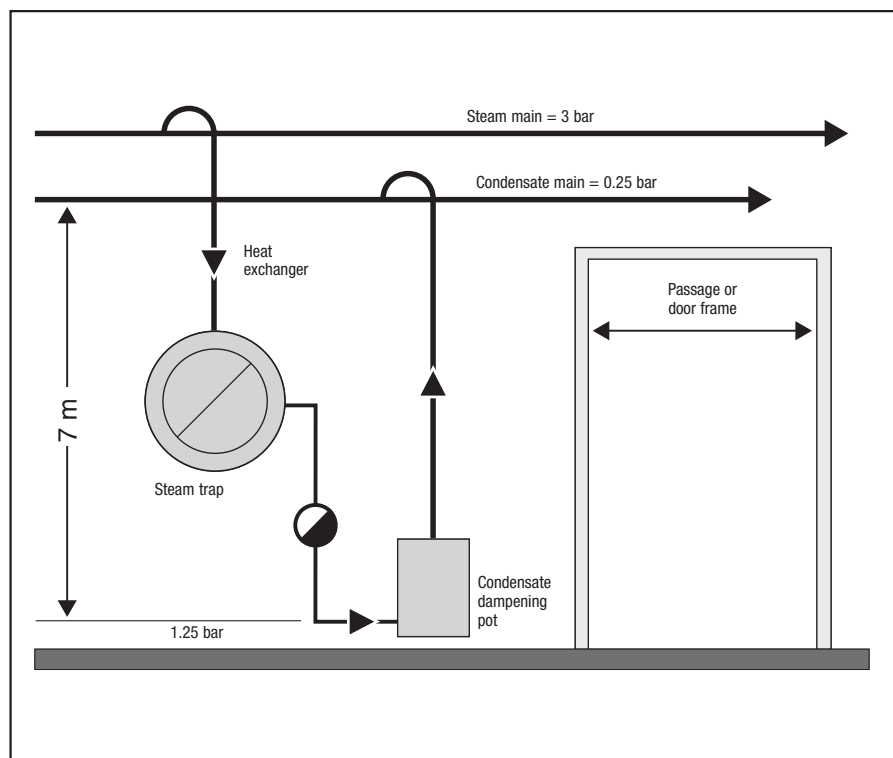

Technical Data

Service pressure	Related temperature	Capacity range	Material	Volume [l]
18 bar	250 °C	up to 15 t/h	S235JRG2 / P265GH	4 to 50

Description

The condensate dampening pot provides a cushioning effect to neutralize waterhammer. The condensate is discharged without noise.

Application

Steam and condensate systems.

Description

Steam separators are used to remove condensate and dirty water carry-over from steam. By this means trouble-free operation and a long service life of the heat exchanger and steam consumer is obtained.

Application

Downstream of steam boilers and steam-generating units.

Between boiler and superheater.

In steamlines ahead of steam manifolds.

In district-heating lines and flash steam lines.

Upstream of turbines, steam engines, steam tools.

For direct heating with steam.

In spray-vapour humidifier systems for air-conditioning plants.

Technical Data

Pressure rating	Nominal sizes DN	Materials
PN 16 PN 40 PN 63 PN 100 PN 160	15 to 500 mm	P235GH
		S235JR+N
		P265GH
		16 Mo 3
		1.4571

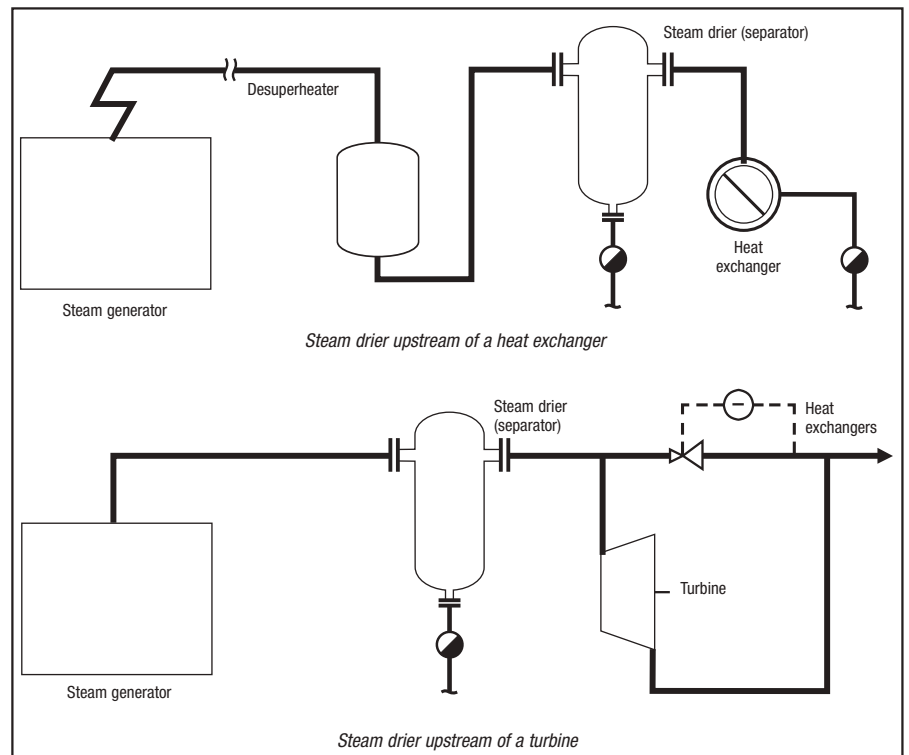
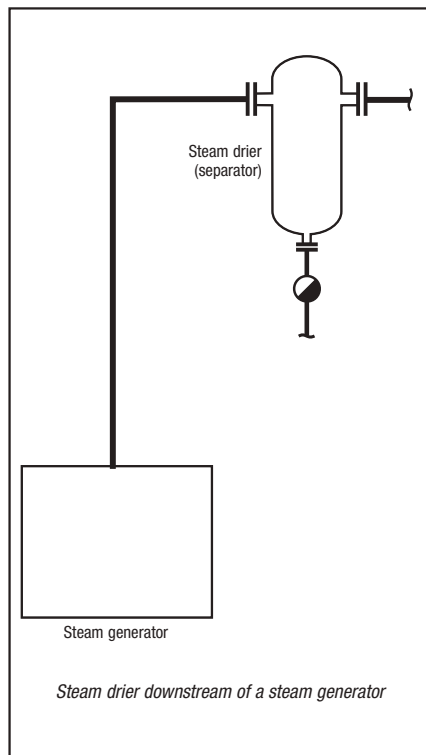

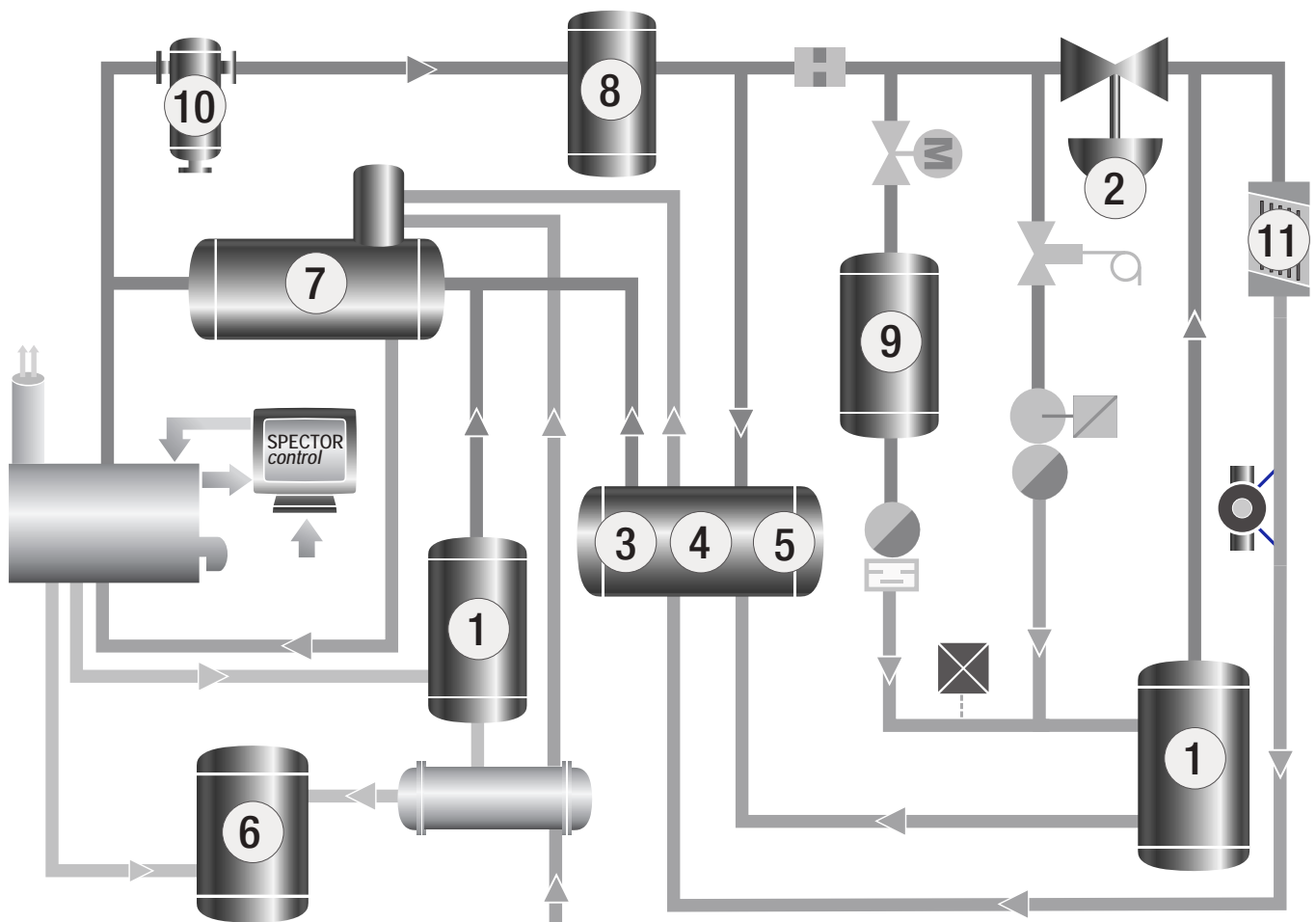

1. Flash vessel
2. Steam pressure reducing station
3. Condensate recovery and return system (rectangular type)
4. Condensate recovery and return system (cylindrical type)
5. Steam-powered condensate return unit
6. Blowdown receiver ("mixing cooler")
7. Feedwater deaerator
8. Water-bath desuperheater

Desuperheater: injection spray type

9. Steam regenerator
10. Steam drier TD
11. Heat exchanger

E-mail: info@de.gestra.com • Fax: +49 421 3503-393

Online: www.gestra.com/Service & Support/Questionnaire for preparing offers

Condensate flowrate _____ kg/h

Condensate temperature _____ °C

Condensate pressure _____ bar(a)

Tank design:

angular round horizontal vertical open closed

Condensate pumps:

Qty. _____

Discharge head _____ mWS

Mains voltage _____

Horizontal pump Vertical pump

Supply options:

Accessories detached Accessories assembled and interconnected

Condensate tank made of:

Steel
 Stainless steel grade 1.4571 (X6CrNiMoTi17-12-2)

Typical Installations

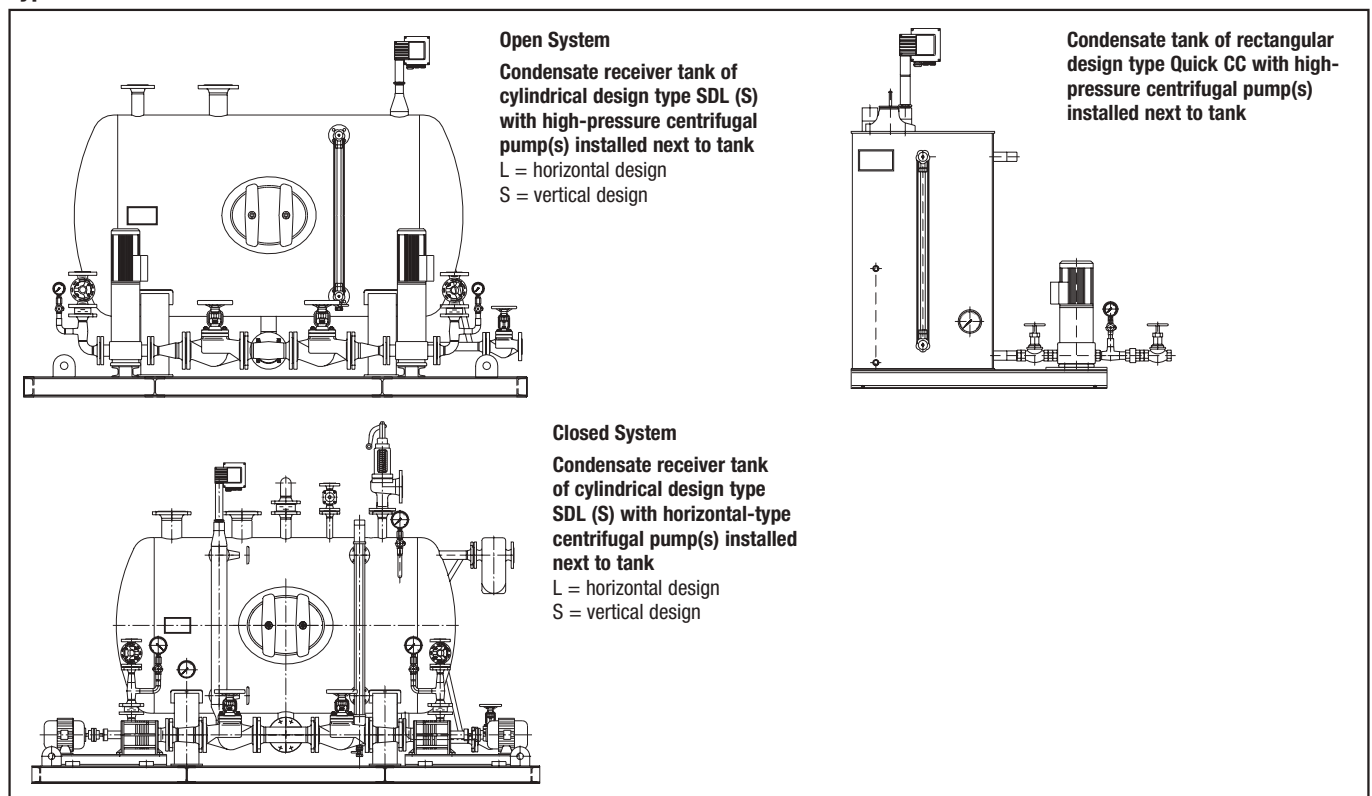

Open System
Condensate receiver tank of cylindrical design type SDL (S) with high-pressure centrifugal pump(s) installed next to tank
L = horizontal design
S = vertical design

Closed System
Condensate receiver tank of cylindrical design type SDL (S) with horizontal-type centrifugal pump(s) installed next to tank
L = horizontal design
S = vertical design

Condensate tank of rectangular design type Quick CC with high-pressure centrifugal pump(s) installed next to tank

Your details

Name / Title
Company Name
Telephone
Fax
E-mail
Date

E-mail: info@de.gestra.com • Fax: +49 421 3503-393

Online: www.gestra.com/Service & Support/Questionnaire for preparing offers

Reducing of steam pressure

yes no

If yes,

Self-acting control

Electro-pneumatic

Steam flowrate _____

Steam pressure:

P₁ _____ bara/psia upstream of pressure reducing station

P₂ _____ bara/psia downstream of pressure reducing and cooling station

Steam temperature:

t₁ _____ °C upstream of pressure reducing station or when no more pressure reduction takes place upstream of cooling unit

t₂ _____ °C downstream of pressure reducing and cooling station

Cooling fluid:

P₄ _____ bar/psi upstream of cooler

if not fitted

t₄ _____ °C upstream of cooler

with pump yes no

Water-bath desuperheater

t₂ = t_s

Injection cooler

t₂ = t_s + > 5° controllable

Supply options for water-bath desuperheater:

Accessories detached

Accessories assembled

Typical Installations

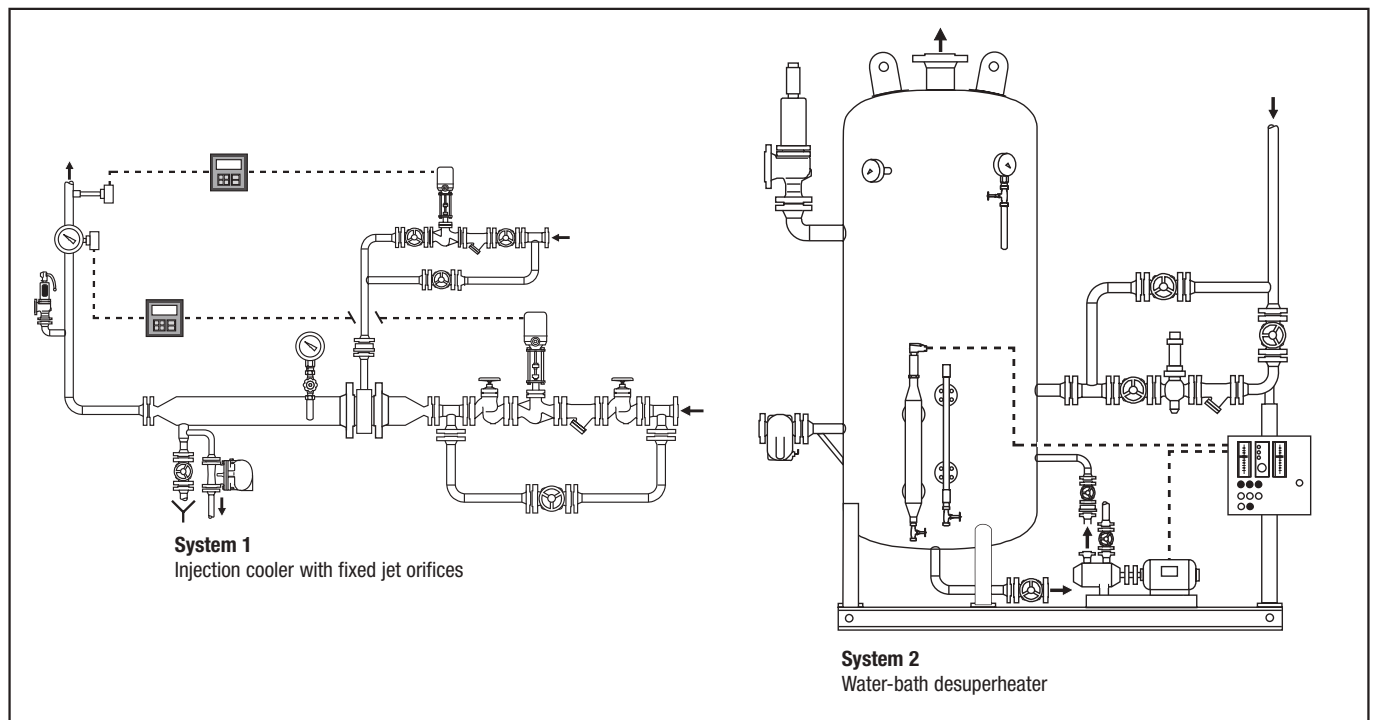

Your details

Name / Title
Company Name
Telephone
Fax
E-mail
Date

E-mail: info@de.gestra.com • Fax: +49 421 3503-393

Online: www.gestra.com/Service & Support/Questionnaire for preparing offers

Pure steam output _____ kg

Service data (primary)

Medium: Steam Hot water
 Pressure _____ bara/psia Temperature On _____ °C
 Temperature Off _____ °C

Services data (secondary)

Medium: Steam Feedwater
 Pressure _____ bara/psia Temperature _____ °C

Control (pressure side) Self-acting Pneumatic

Feedwater control Solenoid valve or control valve Feedwater pump

Application _____

Typical Installation

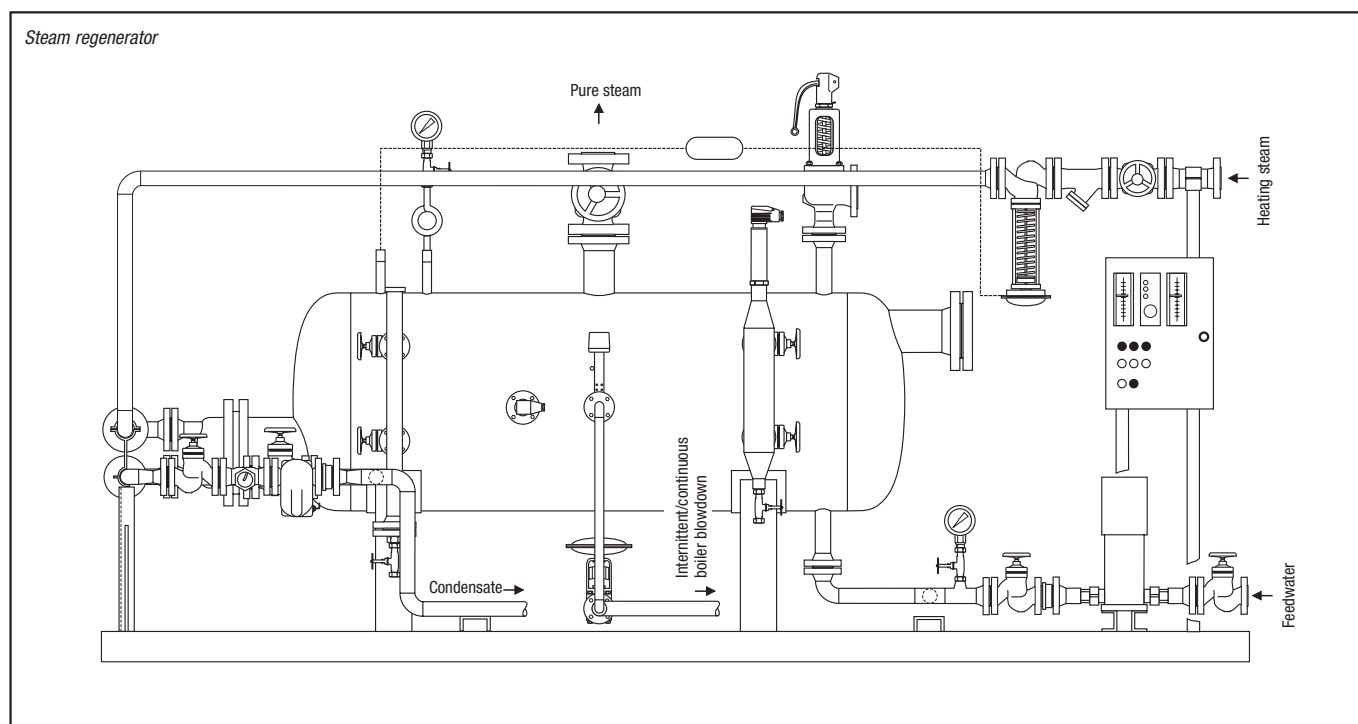

Your details

Name / Title
Company Name
Telephone
Fax
E-mail
Date

E-mail: info@de.gestra.com • Fax: +49 421 3503-393

Online: www.gestra.com/Service & Support/Questionnaire for preparing offers

Boiler capacity _____ kg/h

Make-up water flowrate _____ kg/h Temperature approx. _____ °C

Steam pressure _____ bar(a)

Service pressure (deaerator) _____

Make-up feed control Electric Pneumatic

Pressure control Self-acting Electric Pneumatic

Typical Installation

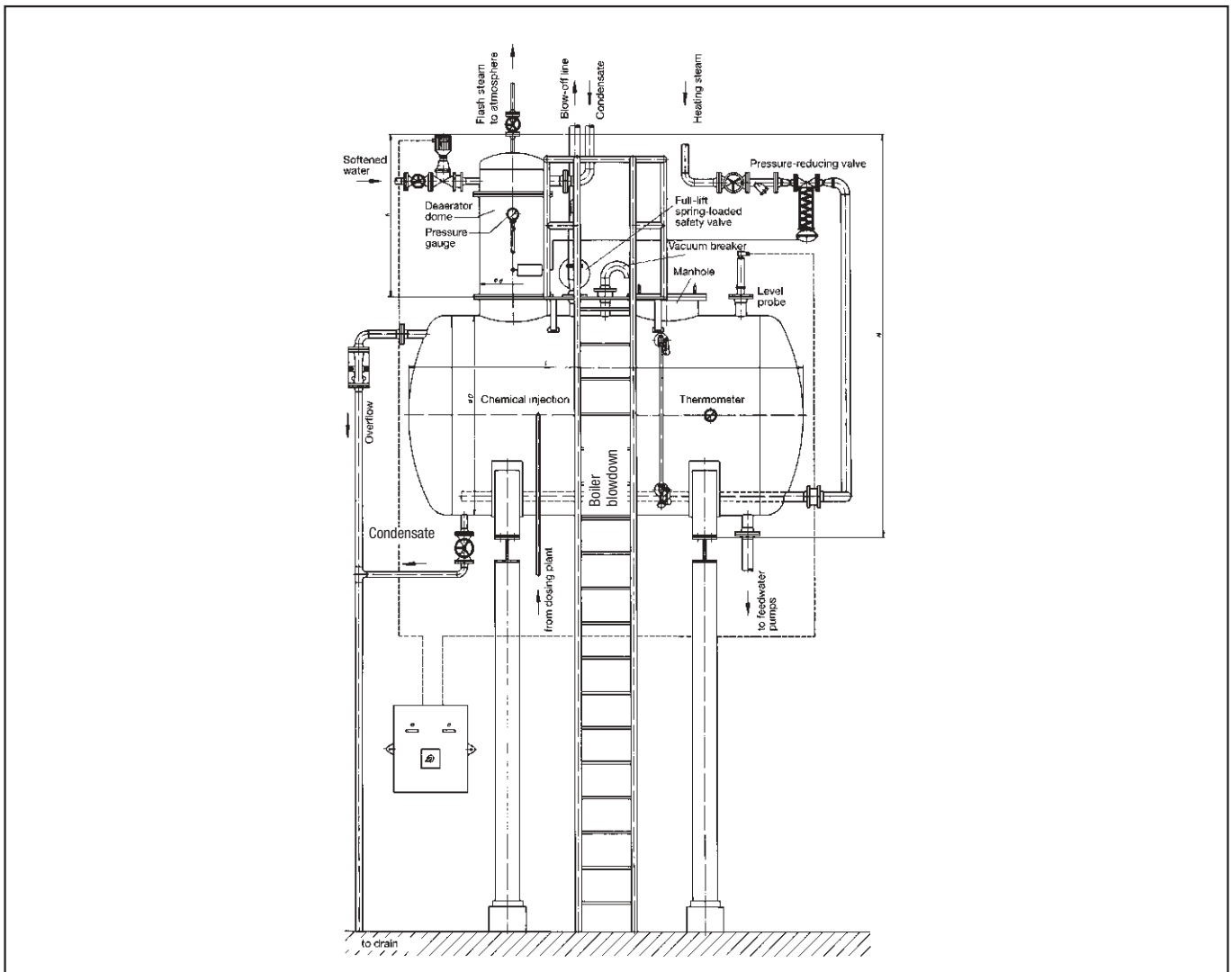

Your details

Name/Title
Company Name
Telephone
Fax
E-mail
Date

E-mail: info@de.gestra.com • Fax: +49 421 3503-393

Online: www.gestra.com/Service & Support/Questionnaire for preparing offers

Pressure p_1 upstream of steam trap at steam user
(boiler pressure at flash vessel)

$P_1 =$ _____ bar(a)/psi(a)

Pressure p_2 of flash steam at flash outlet to low pressure system

$P_2 =$ _____ bar(a)/psi(a)

Pressure p_3 downstream of steam trap after the flash vessel

$P_3 =$ _____ bar(a)/psi(a)

Condensate flowrate to flash off

$m =$ _____ kg/h

Typical Installation

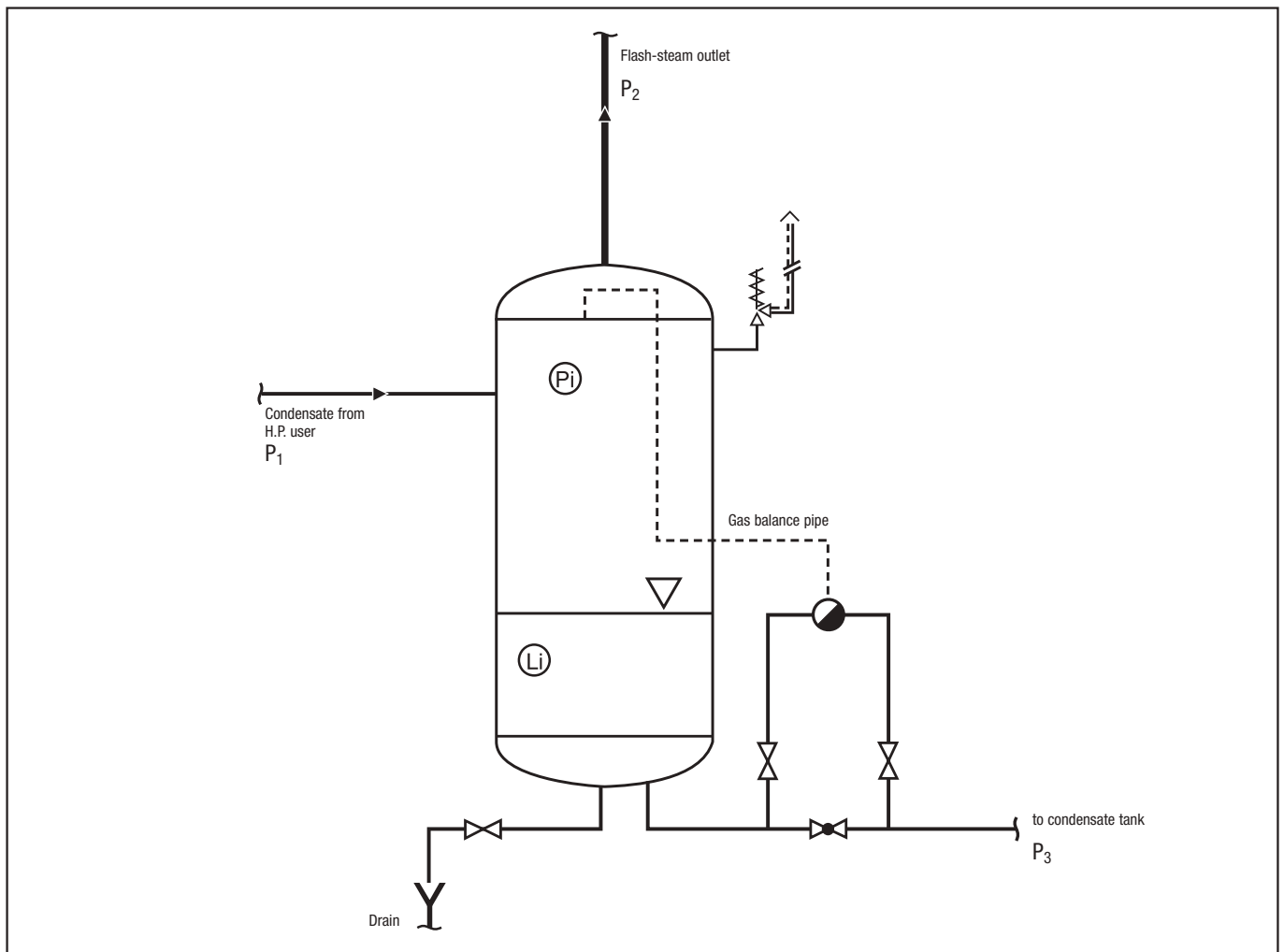

Your details

Name/Title
Company Name
Telephone
Fax
E-mail
Date

E-mail: info@de.gestra.com • Fax: +49 421 3503-393

Online: www.gestra.com/Service & Support/Questionnaire for preparing offers

Hot-water flowrate _____ kg/h

Hot-water temperature _____ °C

Hot-water pressure _____ bar(a)

Cooling-water temperature _____ °C

Cooling-water pressure _____ bar(a)

Material

Steel

Edelstahl 1.4571

Application

Boiler blowdown

Other

Flash steam condensation

Typical Installation

Mixing cooler with cooling-water control and, on request, with additional flash-steam condensation

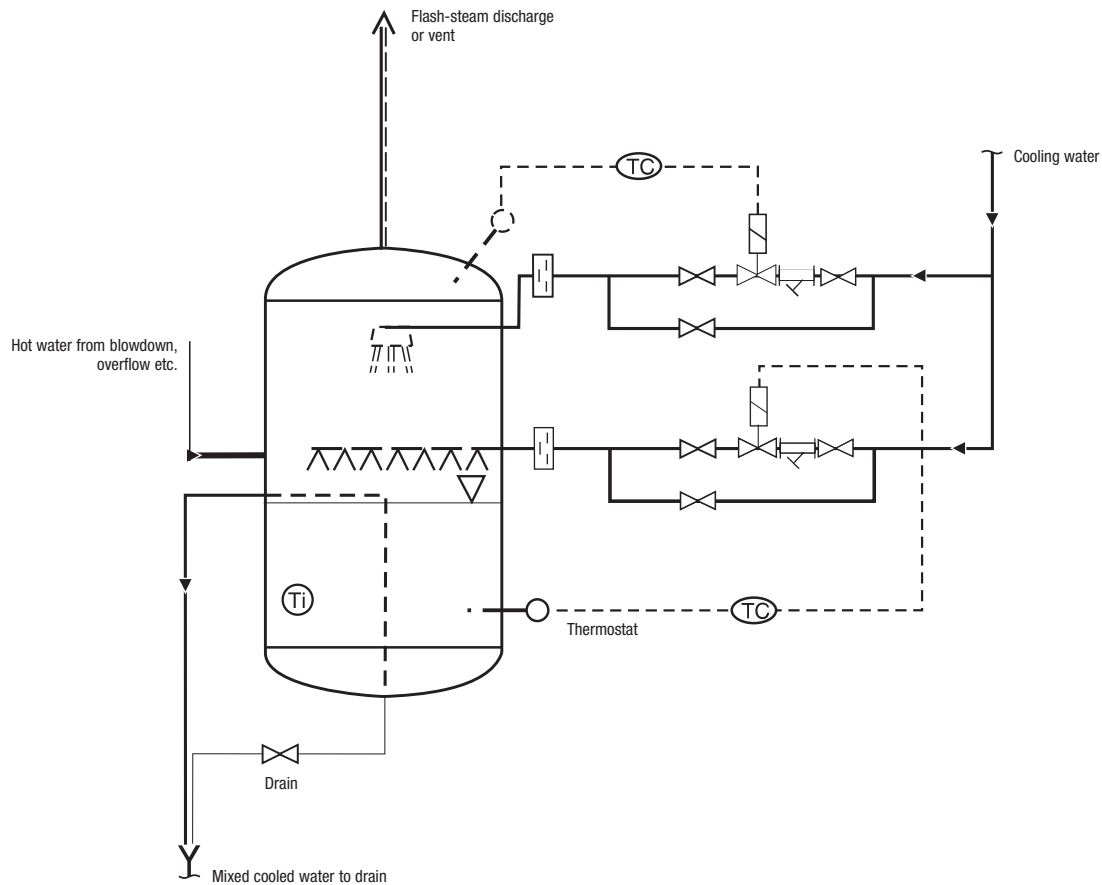

Your details

Name/Title
Company Name
Telephone
Fax
E-mail
Date

E-mail: info@de.gestra.com • Fax: +49 421 3503-393

Online: www.gestra.com/Service & Support/Questionnaire for preparing offers

Thermal output _____

Service data (primary)

Medium: Steam Hot water Thermal oil
 Pressure _____ bar/psi Temperature (in) _____ °C Flowrate _____ kg/h
 Temperature (out) _____ °C
 Material: Steel Stainless steel grade 1.4571
 (X6CrNiMoTi 17-12-2)

Control Self-acting Electric
 Pneumatic

Controlled from the condensate side

Design horizontal tube bundle heat exchanger
 vertical tube bundle heat exchanger
 GESTRA heat exchanger unit type PWT-XPS

Service data (secondary)

Medium: Steam Hot water Thermal oil
 Pressure _____ bar/psi Temperature (in) _____ °C Flowrate _____ kg/h
 Temperature (out) _____ °C
 Material: Steel Stainless steel grade 1.4571
 (X6CrNiMoTi 17-12-2)

Typical Installation

GESTRA Heat Exchanger controlled from the steam side with constant temperature of the secondary circuit

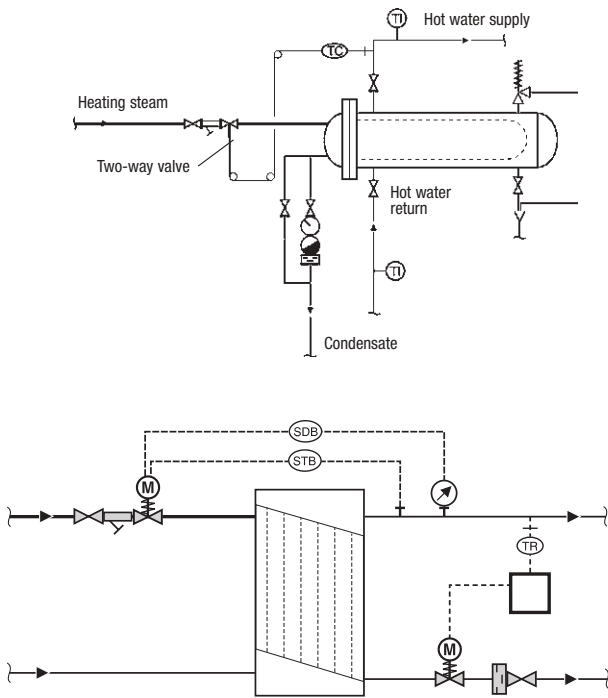

GESTRA Heat exchanger unit type PWT-XPS

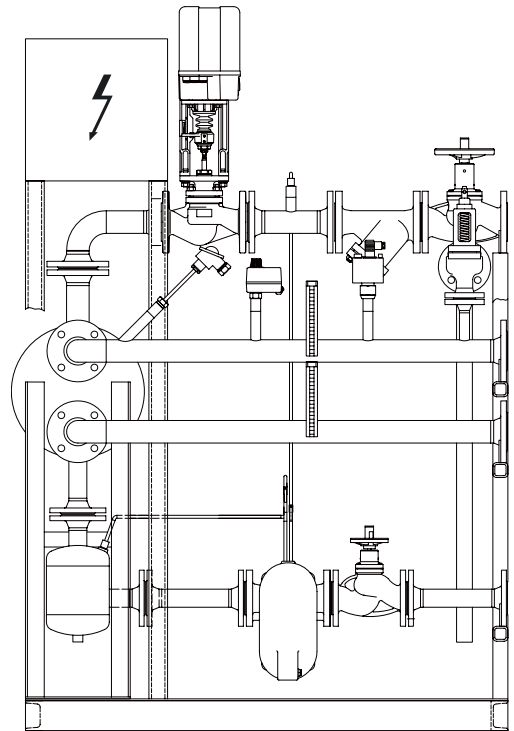

GESTRA heat exchanger, controlled on the condensate side and with safety shut-off on the steam side

Your details

Name / Title
Company Name
Telephone
Fax
E-mail
Date

E-mail: info@de.gestra.com • Fax: +49 421 3503-393

Online: www.gestra.com/Service & Support/Questionnaire for preparing offers

Medium: Saturated steam Superheated steam Air Gas _____

Flowrate: $\dot{m} =$ _____ kg/h $\dot{V}_N =$ _____ Nm³/h

Service pressure: $p =$ _____ bara/psia

Service temperature: $t =$ _____ °C

Admissible pressure: $p =$ _____ barg/psig

Approved temperature: $t =$ _____ °C

Connections: Inlet/Outlet: DN/PN _____

Condensate outlet: DN/PN _____

Material: S235JRG2 (RSt 37-2) P265GH (H II) 16 Mo 3

1.4571 (V4A) _____

Your details

Name/Title
Company Name
Telephone
Fax
E-mail
Date

Academy	Page
Mobile Testing Station, See-Through Demo Facility	174

Tools for Design Engineers, Users & Operators	Page
Programs & Sizing Software	175
GESTRA Steam Traps & Valves Library (2D and 3D CAD drawings)	175
Technical Literature	175

Documentation and Reference Literature	Page
Technical References Guide and Condensate Manual	176
Brochures and Leaflets	176
Technical Infos	176
Data Sheets, Installation and Operating Instructions	178

General Information	Page
Information on ATEX Directive 2014/34/EU	177
Information on Pressure Equipment Directive (PED) 2014/68/EU	178 – 181
Combined Imperial and S. I. Steam Tables	182 – 183
DIN Material Reference Chart	184
Design of GESTRA Valves	185
Product Index	186 – 190

Our GESTRA Academy offers a broad portfolio of in-depth vocational training seminars for design engineers, consultants, manufacturers and operators. As part of the workshops there will be practical hands-on demonstrations at our state-of-the-art simulation facilities on site. Evaluating and understanding what is going on in a steam system helps preventing costly malfunctions and downtime.

Mobile Testing Station

Our mobile testing station is a testing, demonstration and training facility on wheels. We would be happy to send our mobile testing station together with our experienced support engineers to you in order to solve your operating problems directly on site and conduct training seminars on your premises. You provide steam, water and electricity and, by means of our mobile testing station, we provide a comprehensive and personalized workshop tailored to your specific requirements and focusing on steam and condensate systems.

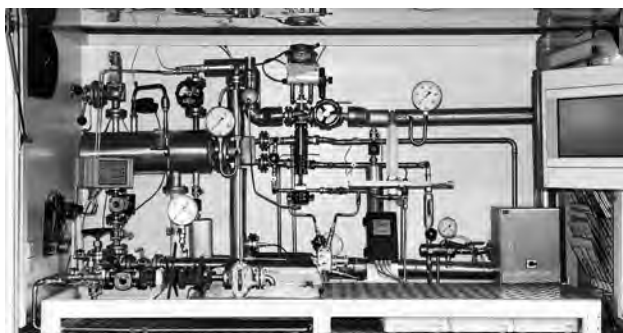

Steam Trap Test Benches

Demonstration of up-to-date electronic monitoring equipment for steam traps up to 20 bar service pressure. The installation clearly illustrates the operational mode of the various systems.

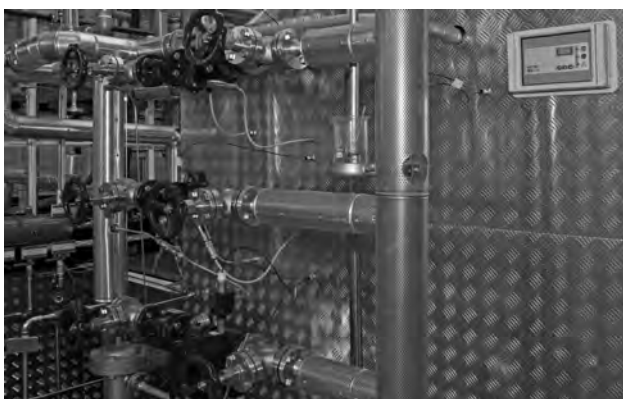

Steam Boiler Demonstration Facility

This simulation facility provides the opportunity to demonstrate the newest and most effective boiler equipment. Design engineers, manufacturers and operators can observe different operating modes and simulations of in-service failures. Thanks to these demonstration sessions individuals gain the knowledge needed to prevent expensive failures and downtime.



See-Through Demo Facility

Our custom-built see-through demo facility makes thermodynamic processes in steam and condensate systems visible. The whole installation is completely made from glass and allows the spectators to see effects and properties otherwise hidden from the human eyes. This facility illustrates in a practical manner some of the more abstract concepts discussed during the workshops and seminars.

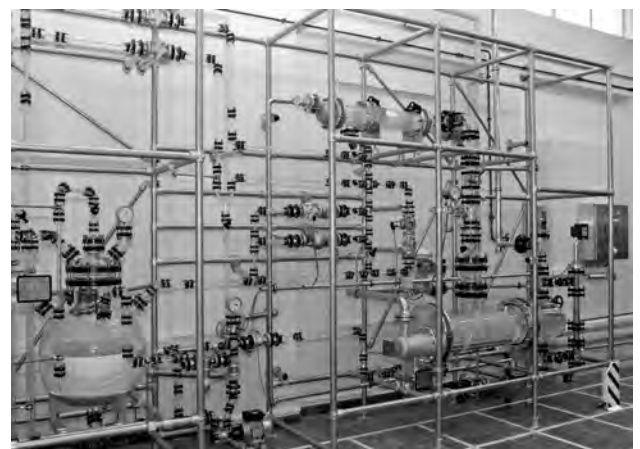

Please call us so that we can schedule a demonstration with our mobile testing station at your facility.
Telephone: +49 421 3503-218/-376

Sizing & Selection Software and Useful Tools for Steam Practitioners

For the following software tools go to [www.gestra.com/Service & Support](http://www.gestra.com/Service%20&%20Support)

CAESar Steam trap selecting & sizing software (multilingual) www.gestra.com

Select by application or by type. Filter criteria: functional type, nominal pressure, end connection and material. Output with specification text and ordering details.

GESTRA CALCUquick

A software tool to help designers and steam practitioners calculate valve sizes and flow velocities and determine steam, condensate and pipe parameters.

Questionnaires for preparing offers

Offer forms sorted according to product, for e-mailing.

STEAM TRAPP – The Steam Trap App for Android and iOS

Mobile information on all current steam traps. Request for offers.

GESTRA Steam Traps & Valves Library

To help you design and plan an installation we offer you our extensive library with CAD drawings.

GESTRA Technical References Guide

Important reference work used in the field of steam and condensate technology. Essential formulae and charts & tables specifying materials, units, standards, inspection requirements, European standards EN, ASME, and useful conversation tables are just some of the issues covered by this useful technical guide.

GESTRA Condensate Manual

This handbook is intended for operators and users and illustrates typical applications encountered in steam and condensate systems, shows examples of installation and describes processes and equipment.

Brochures & Leaflets

For more detailed information on products, properties, designs, function and application.

Technical Infos

Answers are given to frequently asked questions regarding condensate lines, steam, boiler equipment, non-return valves and many more topics.

Data Sheets and Installation Manuals

Technical specification of our products, description of intended use and function. Information on design, installation, maintenance and safe operation. Available in many languages.

Please go to our website for more information:
www.gestra.com/documents/brochures



European Directive 2014/34/EU (ATEX) governs the requirements for equipment that is operated in potentially explosive atmospheres. Here, the potentially explosive atmosphere is the surrounding atmosphere.

As of 20 April 2016, this European Directive has applied to the operation of electrical and non-electrical equipment in the EU member states.

The items of equipment named below have been inspected as regards their suitability for use in potentially explosive atmospheres in accordance with the above-mentioned Directive.

The equipment does not have its own potential ignition source, in accordance with Annex II, section 1.3. Therefore, on the basis of paragraph 2, section (1), the Directive does not apply.

According to paragraph 30 (2) of Regulation (EC) No. 765/2008, these items of equipment must not be labelled with the CE mark in relation to Directive 2014/34/EU. Neither do these items require a Declaration of Conformity as per 2014/34/EU.

When used for their intended purpose – described in the relevant GESTRA data sheets and Installation & Operating Manuals – and as they do not have their own potential ignition source, the items of equipment named below may be used in potentially explosive atmospheres.

The GESTRA items of equipment mentioned below, in the version without electrical or pneumatic attachments, are suitable for operation in the following zones: Zone 0, 1, 2 (gases).

Steam traps, steam trap accessories:

Type AK, BK, DK, IB, MK, SMK, TK, UBK, UC, UNA, VK

Mechanical control valves:

Type BW, CW

Special equipment and vessels for heat recovery:

Type TD, ED

The GESTRA items of equipment mentioned below are suitable for operation in the following zones: Zone 0, 1, 2 (gases) and Zone 20, 21, 22 (dusts).

Check valves:

Type BB, CB, MB, RK, SBO.

Strainers:

Type SZ

Note:

Some electrical and non-electrical items of equipment marketed by GESTRA and not mentioned here can be used in certain potentially explosive atmospheres. If you have any questions about using this equipment in potentially explosive atmospheres for your particular application, please contact us. Please note that certain items of GESTRA equipment have a Declaration of Conformity with other European directives, and therefore bear the CE mark. If necessary, you can find details in the relevant data sheets, Installation & Operating Manuals and Declarations of Conformity.

Bremen, August 2019



Kerstin Borchers
ATEX Officer



Tim Kraemer
Leiter Produktentwicklung

Fluid group 1: hazardous substances, poisonous, flammable
 Fluid group 2: non-hazardous substances, e.g. water, steam, air

Pressure CL acc. to name plate

CE marking yes	Fluid		Valve	Type	Type no.	PN/CL	Size (DN)																					
	Module	Gr. 1					Gr. 2	10/15	20	25	32	40	50	65	80	100	125	150	200	250	300	350	400	450	500	600	700	800
A2 – Check Valves																												
X	H	X	X	BB	12A / 22A / 32A	149	10																					
X	H	X	X	BB	14A / 24A / 34A	149	16																					
X	H	X	X	BB	15A / 25A / 35A	149	25/CL150																					
X	H	X	X	BB	16A / 26A / 36A	149	40/CL300																					
X	H	X	X	BB	17A	149	63																					
X	H	X	X	BB	18A	149	100/CL600																					
X	H	X	X	BB	19A	149	160/CL900																					
X	H	X	X	BB	12C / 22C / 32C	143	10																					
X	H	X	X	BB	14C / 24C / 34C	143	16																					
X	H	X	X	BB	15C / 25C / 35C	143	25/CL150																					
X	H	X	X	BB	16C / 26C / 36C	143	40/CL300																					
X	H	X	X	BB	17C	143	63																					
X	H	X	X	BB	18C	143	100/CL600																					
X	H	X	X	BB	19C	143	160/CL900																					
(X)	H		X	BB	11G / 21G	140	6																					
X	H		X	BB	12G / 22G	140	10																					
X	H		X	BB	14G / 24G	140	16																					
(X)	H		X	CB	14	138	16																					
(X)	H		X	CB	24S	132	16																					
X	H	X	X	CB	26	133	40																					
X	H	X	X	CB	26a	134	40																					
			X	MB	14	091	16	4 (3)	4 (3)	4 (3)	4 (3)	4 (3)	4 (3)	4 (3)														
X	H	X	X	NAF-Check	526520/530 528520/530	448	25																					
X	H	X	X	NAF-Check	526620/630	448	40																					
X	H	X	X	NAF-Check	526822/832	448	100																					
(X)	H	X	X	RK	16a	118	40/CL300	4 (3)	4 (3)	4 (3)	CE	CE	CE	CE	CE	CE												
(X)	H	X	X	RK	16b	124	40	4 (3)	4 (3)	4 (3)	CE	CE	CE	CE	CE	CE												
(X)	H	X	X	RK	16c	117	40	4 (3)	4 (3)	4 (3)	CE	CE	CE	CE	CE	CE												
(X)	H	X	X	RK	16t	125	40	4 (3)	4 (3)	4 (3)	CE	CE	CE	CE	CE	CE												
(X)	H	X	X	RK	26a	114	40	4 (3)	4 (3)	4 (3)	CE	CE	CE	CE	CE	CE												
(X)	H	X	X	RK	29a	109	160/CL...	4 (3)	4 (3)	4 (3)	CE	CE	CE	CE	CE	CE	CE	CE	CE									
(X)	H		X	RK	41	102	16	4 (3)	4 (3)	4 (3)	CE	CE	CE	CE	CE	CE	CE	CE	CE									
(X)	H	X	X	RK	44	103	16	4 (3)	4 (3)	4 (3)	CE	CE	CE	CE	CE	CE	CE	CE	CE									
(X)	H		X	RK	44s	110	16	4 (3)	4 (3)	4 (3)	4 (3)	4 (3)	4 (3)	4 (3)	CE	CE	CE	CE	CE									
(X)	H	X	X	RK	49	107	160	4 (3)	4 (3)	4 (3)	CE	CE	CE	CE	CE	CE												
(X)	H		X	RK	70	095	6	4 (3)	4 (3)	4 (3)	4 (3)	4 (3)	4 (3)	4 (3)	4 (3)	4 (3)	4 (3)	4 (3)	CE									
(X)	H		X	RK	71	100	16	4 (3)	4 (3)	4 (3)	4 (3)	4 (3)	4 (3)	4 (3)	CE	CE	CE											
(X)	H	X	X	RK	76	120	40	4 (3)	4 (3)	4 (3)	CE	CE	CE	CE	CE	CE												
(X)	H	X	X	RK	86	101	40/CL300	4 (3)	4 (3)	4 (3)	CE	CE	CE	CE	CE	CE	CE	CE	CE									
(X)	H	X	X	RK	86a	121	40/CL300	4 (3)	4 (3)	4 (3)	CE	CE	CE	CE	CE	CE	CE	CE	CE									
			X	SBO	11, 21, 31	086, 088, 090	6			4 (3)	4 (3)																	

1. BB DIN- & ASME
 2. DN 800 = ASME 30"
 (DN 750)

Fluid group 1: hazardous substances, poisonous, flammable
 Fluid group 2: non-hazardous substances, e.g. water, steam, air

Pressure CL acc. to name plate

CE marking yes	Fluid		Valve	Type	Type no.	PN/CL	Size (DN)																																		
	Module	Gr. 1					Gr. 2	10/15	20	25	32	40	50	65	80	100	125	150	200	250	300	350	400	450	500	600	700	800	900	1000	1200										
A4 – Self Acting Temperature & Pressure Controller																																									
(X)	H		X	5801		270	16	4 (3)	4 (3)	4 (3)	4 (3)	4 (3)	4 (3)	4 (3)	CE	CE	CE	CE	CE	CE																					
(X)	H		X	5801		270	25	4 (3)	4 (3)	4 (3)	4 (3)	4 (3)	4 (3)	4 (3)	CE	CE	CE	CE	CE	CE	CE	CE																			
(X)	H		X	5801		272	40	4 (3)	4 (3)	4 (3)	4 (3)	4 (3)	4 (3)	4 (3)	CE	CE	CE	CE	CE	CE	CE	CE																			
(X)	H		X	5801		273	40	4 (3)	4 (3)	4 (3)	4 (3)	4 (3)	4 (3)	4 (3)	CE	CE	CE	CE	CE	CE	CE	CE																			
(X)	H		X	5610		274	16	4 (3)	4 (3)	4 (3)	4 (3)	4 (3)	4 (3)	4 (3)	CE	CE	CE																								
(X)	H		X	5610		274	25	4 (3)	4 (3)	4 (3)	4 (3)	4 (3)	4 (3)	4 (3)	CE	CE	CE	CE	CE	CE	CE	CE																			
(X)	H		X	5610		275	40	4 (3)	4 (3)	4 (3)	4 (3)	4 (3)	4 (3)	4 (3)	CE	CE	CE	CE	CE	CE	CE	CE																			
			X	BW	31	032	25+40+CL150	4 (3)	4 (3)	4 (3)		4 (3)			DN 15-25 = PN 40 as from 2002																										
(X)	H	X	X	BW	31A	033	25+40	4 (3)	4 (3)	4 (3)		CE		DN 15-25 = PN 40 as from 2002																											
(X)	H	X	X	BW	31A	033	CL150	4 (3)	4 (3)	4 (3)		CE																													
			X ¹⁾	CW	41	035	16		4 (3)		4 (3)	4 (3)			4 (3)	4 (3)																									
			X ¹⁾	X ¹⁾	CW	41/4	16		4 (3)		4 (3)	4 (3)			4 (3)	4 (3)																									
			X	CW	44	036	25	4 (3)	4 (3)	4 (3)																															
			X	CW	44k	036	25	4 (3)	4 (3)	4 (3)																															
			X	Clorius	L1S	235	16	4 (3)	4 (3)	4 (3)																															
			X	Clorius	L2S	235	16		4 (3)	4 (3)	4 (3)	4 (3)	4 (3)																												
			X	Clorius	L2SR, L3S	235, 239	16	4 (3)	4 (3)	4 (3)	4 (3)	4 (3)	4 (3)																												
(X)			X	Clorius	L3F	239	10							4 (3)	4 (3)	4 (3)	CE																								
			X	Clorius	M1F	236	16	4 (3)	4 (3)	4 (3)	4 (3)	4 (3)	4 (3)																												
(X)			X	Clorius	M1FBN	236	16		4 (3)	4 (3)	4 (3)	4 (3)	4 (3)	CE	CE																										
(X)			X	Clorius	M2F	236	16	4 (3)	4 (3)	4 (3)	4 (3)	4 (3)	4 (3)	CE	CE	CE	CE	CE	CE	CE	CE																				
(X)			X	Clorius	M2FR	236	16		4 (3)	4 (3)	4 (3)	4 (3)	4 (3)	CE	CE	CE	CE	CE	CE	CE	CE																				
(X)			X	Clorius	M3F	239	16		4 (3)	4 (3)	4 (3)	4 (3)	4 (3)	CE	CE	CE	CE	CE	CE	CE	CE																				
(X)			X	Clorius	M3F/M3FM	239	10								4 (3)	4 (3)	CE	CE																							
(X)			X	Clorius	H1F	237	40	4 (3)	4 (3)	4 (3)	4 (3)	4 (3)	CE	CE																											
(X)			X	Clorius	H1FBN	237	40		4 (3)	4 (3)	4 (3)	4 (3)	CE	CE	CE	CE																									
(X)			X	Clorius	H2F	237	40		4 (3)	4 (3)	4 (3)	4 (3)	CE	CE	CE	CE	CE	CE	CE	CE	CE	CE																			
(X)			X	Clorius	H2FR	237	40		4 (3)	4 (3)	4 (3)	4 (3)	CE	CE	CE	CE	CE	CE	CE	CE	CE	CE																			
(X)			X	Clorius	H3F	239	40		4 (3)	4 (3)	4 (3)	4 (3)	CE	CE																											
(X)			X	Clorius	G1F	238	25	4 (3)	4 (3)	4 (3)	4 (3)	4 (3)	CE																												
(X)			X	Clorius	G1FBN	238	25		4 (3)	4 (3)	4 (3)	4 (3)	CE																												
(X)			X	Clorius	G2F	238	25	4 (3)	4 (3)	4 (3)	4 (3)	4 (3)	CE																												
(X)			X	Clorius	G2FR	238	25		4 (3)	4 (3)	4 (3)	4 (3)	CE																												
(X)			X	Clorius	G3F	239	25		4 (3)	4 (3)	4 (3)	4 (3)	CE																												
			X	Clorius	2.05, 4.03, 4.05, 4.10, 8.09, 8.18	245			4 (3)	4 (3)	4 (3)																														
A4 – Control Valves																																									
(X)	H	X	X	GCV			40	4 (3)	4 (3)	4 (3)	4 (3)	CE	CE	CE	CE	CE	CE	CE	CE	CE	CE																				
(X)*	A1, H		X	ZK	29	754	40 - 160		4 (3)	4 (3)	4 (3)	CE	CE	CE	CE	CE	CE	CE	CE	CE	CE																				
(X)	A1, H		X	ZK	210	013, 393	250		4 (3)	4 (3)		CE	CE	CE																											
(X)	A1, H		X	ZK	213		–					CE	CE	CE	CE	CE	CE	CE	CE	CE	CE	CE	CE	CE	CE	CE	CE	CE	CE	CE	CE	CE	CE	CE	CE	CE	CE	CE	CE	CE	
(X)*	A1, H		X	ZK	313	757	–		4 (3)	4 (3)	4 (3)	CE	CE	CE	CE	CE	CE	CE	CE	CE	CE																				
(X)	A1, H		X	ZK	412	758	–		4 (3)	4 (3)			CE																												
(X)	A1, H		X	ZK	513	759	–						CE	CE	CE	CE	CE	CE	CE	CE	CE	CE	CE	CE	CE	CE	CE	CE	CE	CE	CE	CE	CE	CE	CE	CE	CE	CE	CE	CE	
(X)	A1, H		X	ZK	610, 613		–						CE	CE	CE	CE	CE	CE	CE	CE	CE	CE	CE	CE	CE	CE	CE	CE	CE	CE	CE	CE	CE	CE	CE	CE	CE	CE	CE	CE	

¹⁾ for liquid fluids only

Gauge Pressure		Absolute Pressure		Saturation Temperature		Specific Enthalpy				Specific Volume Steam	
				t_s		Water	Evaporation	Water	Evaporation	V_g	
bar g	psi g	bar a	psi a	°C	°F	Sensible heat (h_f) kJ/kg	Latent heat (h_{fg}) kJ/kg	Sensible heat (h_f) Btu/lb	Latent heat (h_{fg}) Btu/lb	m ³ /kg	ft ³ /lb
-0.96	28.4	0.05	0.725	32.9	91	138	2423	59	1042	28.2	452
-0.91	27.0	0.1	1.45	45.8	114	192	2392	82	1029	14.7	236
-0.86	25.5	0.15	2.18	54.0	129	226	2373	97	1020	10.0	160
-0.81	24.0	0.2	2.90	60.1	140	251	2358	108	1014	7.65	123
-0.76	22.5	0.25	3.63	65.0	149	272	2346	117	1009	6.20	99.3
-0.71	21.1	0.3	4.35	69.1	156	289	2336	124	1004	5.23	83.8
-0.66	19.6	0.35	5.08	72.7	163	304	2327	131	1000	4.53	72.6
-0.61	18.1	0.4	5.80	75.9	169	318	2319	137	997	3.99	63.9
-0.56	16.6	0.45	6.53	78.7	174	330	2312	142	994	3.58	57.3
-0.51	15.1	0.5	7.25	81.3	178	341	2305	147	991	3.24	51.9
-0.46	13.7	0.55	7.98	83.7	183	351	2299	151	988	2.96	47.4
-0.41	12.2	0.6	8.70	85.9	187	360	2294	155	986	2.73	43.7
-0.36	10.7	0.65	9.43	88.0	190	369	2288	159	984	2.54	40.7
-0.31	9.24	0.7	10.2	90.0	194	377	2283	162	982	2.37	38.0
-0.26	7.77	0.75	10.9	91.8	197	384	2279	165	980	2.22	35.6
-0.21	6.29	0.8	11.6	93.5	200	392	2274	169	978	2.09	33.5
-0.16	4.81	0.85	12.3	95.1	203	399	2270	172	976	1.97	31.6
-0.11	3.34	0.9	13.1	96.7	206	405	2266	174	974	1.87	30.1
-0.06	1.86	0.95	13.8	98.2	209	411	2262	177	972	1.78	28.5
-0.01	0.38	1.0	14.5	99.6	211	418	2258	179	971	1.69	27.1
0	0	1.013	14.696	100	212	419	2257	180	970	1.67	26.8
0.1	1.45	1.11	16.1	103	217	430	2250	185	967	1.53	24.5
0.2	2.90	1.21	17.5	105	221	441	2243	190	964	1.41	22.6
0.3	4.35	1.31	19.0	107	225	450	2237	194	962	1.31	21.0
0.4	5.80	1.41	20.5	110	230	460	2231	198	959	1.23	19.7
0.5	7.25	1.51	21.9	112	234	468	2226	201	957	1.15	18.4
0.6	8.70	1.61	23.4	114	237	476	2220	205	954	1.08	17.3
0.7	10.2	1.71	24.8	115	239	484	2215	208	952	1.02	16.3
0.8	11.6	1.81	26.3	117	243	492	2211	212	951	0.971	15.6
0.9	13.1	1.91	27.7	119	246	499	2206	215	948	0.923	14.8
1.0	14.5	2.01	29.2	120	248	506	2201	218	946	0.881	14.1
1.1	16.0	2.11	30.6	122	252	512	2197	220	945	0.841	13.5
1.2	17.4	2.21	32.1	123	253	519	2193	223	943	0.806	12.9
1.3	18.9	2.31	33.5	125	257	525	2189	226	941	0.773	12.4
1.4	20.3	2.41	35.0	126	259	531	2185	228	939	0.743	11.9
1.5	21.8	2.51	36.4	128	262	536	2181	230	938	0.714	11.4
1.6	23.2	2.61	37.9	129	264	542	2177	233	936	0.689	11.0
1.7	24.7	2.71	39.3	130	266	547	2174	235	935	0.665	10.7
1.8	26.1	2.81	40.8	131	268	552	2170	237	933	0.643	10.3
1.9	27.6	2.91	42.2	133	271	557	2167	240	932	0.622	9.96
2.0	29.0	3.01	43.7	134	273	562	2163	242	930	0.603	9.66
2.2	31.9	3.21	46.6	136	277	572	2157	246	927	0.568	9.10
2.4	34.8	3.41	49.5	138	280	581	2151	250	925	0.536	8.59
2.6	37.7	3.61	52.4	140	284	589	2145	253	922	0.509	8.15
2.8	40.6	3.81	55.3	142	288	597	2139	257	920	0.483	7.74
3.0	43.5	4.01	58.2	144	289	605	2133	260	917	0.461	7.38
3.2	46.4	4.21	61.1	146	293	613	2128	264	915	0.440	7.05
3.4	49.3	4.41	64.0	147	297	620	2123	267	913	0.422	6.76
3.6	52.2	4.61	66.9	149	298	627	2118	270	911	0.405	6.49
3.8	55.1	4.81	69.8	150	302	634	2113	273	908	0.389	6.23
4.0	58.0	5.01	72.7	152	304	641	2108	276	906	0.374	5.99
4.2	60.9	5.21	75.6	153	307	647	2104	278	905	0.361	5.78
4.4	63.8	5.41	78.5	155	309	653	2099	281	902	0.348	5.57
4.6	66.7	5.61	81.4	156	313	659	2095	283	901	0.336	5.38
4.8	69.6	5.81	84.3	158	315	665	2090	286	899	0.325	5.21
5.0	72.5	6.01	87.2	159	316	671	2086	289	897	0.315	5.01
5.5	79.8	6.51	94.4	162	324	685	2076	295	893	0.292	4.68
6.0	87.0	7.01	102	165	329	698	2066	300	888	0.272	4.36
6.5	94.3	7.51	109	168	333	710	2057	305	884	0.255	4.09
7.0	102	8.01	116	171	338	721	2048	310	880	0.240	3.84
7.5	109	8.51	123	173	343	733	2039	315	877	0.227	3.64
8.0	116	9.01	131	175	347	743	2031	319	873	0.215	3.44
8.5	123	9.51	138	178	351	753	2023	324	870	0.204	3.27
9.0	131	10.0	145	180	354	763	2015	328	866	0.194	3.11
9.5	138	10.5	152	182	360	773	2008	332	863	0.185	2.96
10.0	145	11.0	160	184	363	782	2000	336	860	0.177	2.84
10.5	152	11.5	167	186	367	790	1993	340	857	0.171	2.74
11.0	160	12.0	174	188	370	798	1986	344	854	0.163	2.61
11.5	167	12.5	181	190	374	807	1979	347	851	0.157	2.51
12.0	174	13.0	189	192	376	815	1973	350	848	0.151	2.42
12.5	181	13.5	196	193	379	823	1966	354	845	0.146	2.34
13.0	189	14.0	203	195	383	830	1960	357	843	0.141	2.26
13.5	196	14.5	210	197	385	838	1953	360	840	0.136	2.18
14.0	203	15.0	218	198	388	845	1947	363	837	0.132	2.11
14.5	210	15.5	225	200	392	852	1941	366	834	0.128	2.05
15.0	218	16.0	232	202	394	859	1935	369	832	0.124	1.99
15.5	225	16.5	239	203	397	866	1929	372	829	0.120	1.92
16.0	232	17.0	247	204	399	872	1923	375	827	0.117	1.87
16.5	239	17.5	254	205	401	879	1918	378	824	0.114	1.83
17.0	247	18.0	261	207	405	885	1912	381	822	0.110	1.76
17.5	254	18.5	268	209	408	891	1907	383	820	0.108	1.73

14.5 psi = 1 bar

Gauge Pressure		Absolute Pressure		Saturation Temperature t_s		Specific Enthalpy				Specific Volume Steam V_g	
bar g	psi g	bar a	psi a	°C	°F	Water Sensible heat (h_f) kJ/kg	Evaporation Latent heat (h_{fg}) kJ/kg	Water Sensible heat (h_f) Btu/lb	Evaporation Latent heat (h_{fg}) Btu/lb	m ³ /kg	ft ³ /lb
18.0	261	19.0	276	210	410	897	1901	386	817	0.105	1.68
18.5	268	19.5	283	211	412	903	1896	388	815	0.103	1.65
19.0	276	20.0	290	213	415	909	1890	391	813	0.100	1.60
19.5	283	20.5	297	214	417	915	1885	393	810	0.0972	1.56
20.0	290	21.0	305	215	419	920	1880	396	808	0.0949	1.52
21.0	305	22.0	319	217	423	931	1870	400	804	0.0906	1.45
22.0	319	23.0	334	220	428	942	1860	405	800	0.0868	1.39
23.0	334	24.0	348	222	432	952	1850	409	795	0.0832	1.33
24.0	348	25.0	363	224	435	962	1841	414	792	0.0797	1.28
25.0	363	26.0	377	226	439	972	1831	418	787	0.0768	1.23
26.0	377	27.0	392	228	442	982	1822	422	783	0.0740	1.19
27.0	392	28.0	406	230	446	991	1813	426	779	0.0714	1.14
28.0	406	29.0	421	232	450	1000	1804	430	776	0.0689	1.10
29.0	421	30.0	435	234	453	1009	1796	434	772	0.0666	1.07
30.0	435	31.0	450	236	457	1017	1787	437	768	0.0645	1.03
31.0	450	32.0	464	238	460	1026	1779	441	765	0.0625	1.00
32.0	464	33.0	479	239	462	1034	1770	445	761	0.0605	0.97
33.0	479	34.0	493	241	466	1042	1762	448	758	0.0587	0.94
34.0	493	35.0	508	243	469	1050	1754	451	754	0.0571	0.915
35.0	508	36.0	522	244	471	1058	1746	455	751	0.0554	0.887
36.0	522	37.0	537	246	475	1066	1737	458	747	0.0539	0.863
37.0	537	38.0	551	247	477	1073	1730	461	744	0.0524	0.839
38.0	551	39.0	566	249	480	1080	1722	464	740	0.0510	0.817
39.0	566	40.0	580	250	482	1087	1714	467	737	0.0498	0.798
40.0	580	41.0	595	252	486	1095	1706	471	733	0.0485	0.777
41.0	595	42.0	609	253	487	1102	1699	474	730	0.0473	0.758
42.0	609	43.0	624	255	491	1108	1691	476	727	0.0461	0.738
43.0	624	44.0	638	256	493	1115	1684	479	724	0.0451	0.722
44.0	638	45.0	653	258	496	1122	1676	482	721	0.0441	0.706
45.0	653	46.0	667	259	498	1129	1669	485	718	0.0431	0.690
46.0	667	47.0	682	260	500	1135	1662	488	715	0.0421	0.674
47.0	682	48.0	696	261	502	1142	1654	491	711	0.0412	0.660
48.0	696	49.0	711	263	505	1148	1647	494	708	0.0403	0.646
49.0	711	50.0	725	264	507	1155	1640	497	705	0.0395	0.633
50.0	725	51.0	740	265	509	1161	1633	499	702	0.0386	0.618
52.0	754	53.0	769	268	514	1173	1619	504	696	0.0371	0.594
54.0	783	55.0	798	270	518	1185	1605	509	690	0.0356	0.570
56.0	812	57.0	827	272	522	1197	1591	515	684	0.0343	0.549
58.0	841	59.0	856	274	525	1208	1577	519	678	0.0330	0.529
60.0	870	61.0	885	277	531	1219	1564	524	672	0.0319	0.511
62.0	899	63.0	914	279	534	1230	1551	529	667	0.0308	0.493
64.0	928	65.0	943	281	538	1241	1538	534	661	0.0297	0.476
66.0	957	67.0	972	283	541	1251	1525	538	656	0.0288	0.461
68.0	986	69.0	1001	285	545	1262	1512	543	650	0.0278	0.445
70.0	1015	71.0	1030	287	549	1272	1499	547	644	0.0270	0.432
72.0	1044	73.0	1059	289	552	1283	1486	552	639	0.0261	0.418
74.0	1073	75.0	1088	291	556	1293	1473	556	633	0.0253	0.405
76.0	1102	77.0	1117	292	559	1303	1460	560	628	0.0246	0.394
78.0	1131	79.0	1146	294	561	1312	1447	564	622	0.0239	0.383
80.0	1160	81.0	1175	296	565	1322	1435	568	617	0.0232	0.372
82.0	1189	83.0	1204	298	568	1331	1422	572	611	0.0226	0.362
84.0	1218	85.0	1233	299	570	1341	1410	576	606	0.0219	0.351
86.0	1247	87.0	1262	301	574	1350	1398	580	601	0.0213	0.341
88.0	1276	89.0	1291	302	576	1359	1385	584	595	0.0208	0.333
90.0	1305	91.0	1320	304	579	1368	1368	588	590	0.0202	0.324
92.0	1334	93.0	1349	305	581	1377	1360	592	585	0.0197	0.316
94.0	1363	95.0	1378	307	585	1386	1348	596	580	0.0192	0.308
96.0	1392	97.0	1407	309	588	1395	1336	600	574	0.0187	0.300
98.0	1421	99.0	1436	310	590	1404	1323	604	569	0.0183	0.293
100.0	1450	101.0	1465	312	594	1412	1311	607	564	0.0178	0.285
105.0	1523	106.0	1537	315	599	1433	1280	616	550	0.0168	0.269
110.0	1595	111.0	1610	319	606	1454	1249	625	537	0.0158	0.253
115.0	1668	116.0	1683	322	612	1475	1218	634	524	0.0149	0.239
120.0	1741	121.0	1755	325	617	1495	1188	643	511	0.0141	0.226
125.0	1813	126.0	1828	328	622	1515	1157	651	497	0.0133	0.213
130.0	1886	131.0	1900	331	628	1535	1125	660	484	0.0126	0.202
135.0	1958	136.0	1973	334	633	1555	1093	668	470	0.0120	0.192
140.0	2031	141.0	2045	337	639	1575	1060	677	456	0.0114	0.183
145.0	2103	146.0	2118	340	644	1595	1027	686	442	0.0108	0.173
150.0	2176	151.0	2190	343	649	1614	994	694	427	0.0102	0.163
155.0	2248	156.0	2263	345	653	1634	960	702	413	0.00972	0.156
160.0	2321	161.0	2335	348	658	1654	925	711	398	0.00922	0.148
165.0	2393	166.0	2408	350	662	1674	888	720	382	0.00875	0.140
170.0	2466	171.0	2480	353	667	1694	850	728	365	0.00829	0.133
175.0	2538	176.0	2553	355	671	1715	811	737	349	0.00785	0.126
180.0	2611	181.0	2625	357	675	1736	769	746	331	0.00743	0.119
185.0	2683	186.0	2698	360	680	1759	726	756	312	0.00701	0.112
190.0	2756	191.0	2770	362	684	1782	679	766	292	0.00660	0.106
195.0	2828	196.0	2843	364	687	1806	628	776	270	0.00619	0.0992
200.0	2901	201.0	2915	366	691	1833	562	788	242	0.00577	0.0924

14.5 psi = 1 bar

EN Material Designation		Old Material Designation (DIN)		ASTM	Material
Number	Symbol	Number	Symbol	equivalent ¹⁾	
1.0038	235JRG2	1.0038	RSt 37-2	A284-B	Constructional steel
1.0315	P235G2TH	1.0315	ST 37.8	–	Constructional steel
1.0345	P235GH	1.0345	ST 35.8 (Hl)	A285-CA	High-quality steel (structural steel)
1.0460	P250GH	1.0460	C22.8	A105	Forged steel, unalloyed (carbon steel)
1.0619	GP240GH	1.0619	GS-C 25	A216-WCB	Cast steel (carbon steel)
1.4006	X12Cr13	1.4006	X10 Cr 13	A182-F6A	Chromium steel
1.4008	GX7CrNiMo12-1	1.4008	G-X 8 CrNi 13	–	Cast stainless steel
1.4021	X20Cr13	1.4021	X20 Cr 13	AISI 420	Chromium steel
1.4027	GX20Cr14	1.4027	G-X 20 Cr 14	–	(Cast) chromium steel
1.4107	GX8CrNi12	1.4107	G-X 8 CrNi 12	A217-CA15	Chromium steel
1.4301	X5CrNi18-10	1.4301	X5 CrNi 18 10	A182-F304	Forged stainless steel, austenitic
1.4308	GX5CrNi19-10	1.4308	G-X 6CrNi 18 9	A351-CF8	Cast stainless steel, austenitic
1.4317	GX4CrNi13-4	–	–	A743 CA6NM	Cast stainless steel
1.4404	X2CrNiMo17-12-2	1.4404	X2CrNiMo17132	A182 F316L	Forged stainless steel, austenitic
1.4408	GX5CrNiMo19-11-2	1.4408	G-X 6CrNiMo 18 10	A351-CF8M	Cast stainless steel, austenitic
1.4435	X2CrNiMo18-14-3	1.4435	X2 CrNiMo 18 14 3	AISI 316L	Stainless steel, forged, austenitic
1.4541	X6CrNiTi18-10	1.4541	X6 CrNiTi 18 10	–	Forged stainless steel, austenitic
1.4550	X6CrNiNb18-10	1.4550	X6 CrNiNb 18 10	A182-F347	Forged stainless steel, austenitic
1.4552	GX5CrNiNb19-11	1.4552	G-X 5 CrNiNb 18 9	A351-CF8C	Cast stainless steel, austenitic
1.4571	X6CrNiMoTi17-12-2	1.4571	X6 CrNiMoTi 17 12 2	AISI 316Ti	Forged stainless steel, austenitic
1.4581	GX5CrNiMoNb19-11-2	1.4581	G-X 5 CrNiMoNb 18 10	–	Cast stainless steel, austenitic
1.4901	X10CrWoMoVNB9-2	–	–	A182-F92	Forged steel, highly heat resistant
1.4903	X10CrMoVNB9-1	1.4903	X10 CrMoVNb 91	A182-F91	Forged steel, highly heat resistant
1.4922	X20 CrMo V11-1	1.4922	X20 CrMo V12 1	–	Forged steel, heat resistant
1.4923	X22CrMoV12-1	1.4923	X22 CrMo V12 1	–	Forged steel, heat resistant
1.4980	X6NiCrTiMoVB25-15-2	1.4980	X5NiCrTi 26 15	–	Forged steel, heat resistant
1.4496	X7 CrNiMo BNb 16-16	1.4986	X8 CrNiMo BNb 16 16	–	Forged steel, heat resistant
1.5415	16Mo3	1.5415	15 Mo 3	A182-F1	Forged steel, heat resistant
1.5419	G20Mo5	1.5419	GS-22 Mo 4	A217-WC1	Cast steel, heat resistant
1.7225	42CrMo4	1.7225	42CrMo4	A193-B7	Forged steel, heat resistant
1.7335	13CrMo4-5	1.7335	13 CrMo 4 4	A182-F12-2	Forged steel, heat resistant
1.7357	G17CrMo5-5	1.7357	GS-17 CrMo 5 5	A217-WC6	Cast steel, heat resistant
1.7380	10CrMo9-10	1.7380	10 CrMo 9 10	A182 F22-3	Forged steel, heat resistant
1.7383	11CrMo9-10	–	–	A182 F22-3	Forged steel, heat resistant
1.7709	21CrMoV 5-7	1.7709	21CrMoV 5 7	–	Forged steel, heat resistant
2.4600	Hastelloy B-3	2.4600	NiMo 29Cr	B335/564	Hastelloy B
2.4610	NiMo 16Cr 16Ti	2.4610	NiMo 16Cr 16Ti	B574	Hastelloy C
2.4632	Nimonic 90	2.4632	NiCr20 Co18Ti	–	Nimonic 90
2.4669	Inconel X750	2.4669	NiCr15 Fe7 TiAl	B637, NACE MR-01-75	Inconel X750
3.7035	Ti 2	3.7035	–	B348/381	Titan
5.1301 (EN-JL 1040)	EN-GJL-250	0.6025	GG-25	A126-B	Grey cast iron
5.3103 (EN-JS 1025)	EN-GJS-400-18-LT	0.7043	GGG-40.3	A395	S. G. (ductile) iron
5.3106 (EN-JS 1030)	EN-GJS-400-15	0.7040	GGG-40	A536 60-40-18	S. G. (ductile) iron to AD 2000 A4/W3/2
5.4202 (EN-JM 1030)	EN-GJMW-400-5	0.8040	GTW-40	–	S. G. (ductile) iron
(EN-JS 1049) ²⁾	(EN-GJS-400-18-U-LT)	0.7043	GGG-40.3	A395	Whiteheart malleable cast iron
CW608N	CuZn 38 Pb 2	2.0371	CuZn 38 Pb 1.5 (MS60)	–	Hot-pressed brass
CW614N	CuZn 39 Pb 3	2.0401	CuZn 39 Pb 3	–	Brass
CW617N	Cu Zn 40 Pb 2	2.0402	CuZn 40 Pb 2	–	Brass
CW710R	CuZn 35 Ni3Mn2Al Pb	2.0540	CuZn 35 Ni 2	–	Special brass
CW718R	CuZn 39 Mn1Al Pb Si	2.0561	CuZn 40 Al 1	–	Special brass
CC332G	CuAl10Ni3Fe2-C	2.0970.01	G-CuAl 9 Ni	–	Bronze
CC480K-GS	CuSn10-Cu	2.1050.01	G-CuSn 10	–	Bronze
CC483K-GS	CuSn12-C	2.1052.04	GC-CuSn 12	–	Bronze

¹⁾ Physical and chemical properties comply with DIN grade. ASTM nearest equivalent grade is stated for guidance only.

²⁾ Replaced by 5.3103

Raised Faces at a glance – Comparison Flange Standard DIN with EN 1092-1

old (DIN)			new (EN 1092-1)			Remark
Raised face	Designation	Admissible tolerance for roughness	Raised face	Designation	Admissible tolerance for roughness	
C	Standard up to PN 40	N11/N10	./.			Form C (old) is replaced by form B1 (new)
D		N9/N8	B1	Standard up to PN 40	N10/N8	Like form D but with def. groove
E	Standard up to PN 63	N8/N7	B2	Standard up to PN 63	N8/N6	Different tolerance for roughness
F	Tongue	N9/N8	C	Tongue	N8/N6	Tongue heights do not match!
N	Groove	N9/N8	D	Groove	N8/N6	Groove depths do not match!
V	Male face	N11/N10	E	Male face	N10/N8	Heights of male faces do not match!
R	Female face	N11/N10	F	Female face	N10/N8	Heights of female faces do not match!
V14	Male face with turned groove	N11/N10	H	O-ring groove	N8/N6	Dimensions identical
R14	Female face to V14	N11/N10	G	O-ring for male face	N8/N6	Dimensions identical
L	Turned groove with convex seal	N6	./.			
M	Bevel with welded diaphragm seal	N8/N7	./.			

Since some flange faces are **not interchangeable** with the associated DIN versions please state the **standard** and the **form of the face**.

Example: BK 45 DN 20 PN 40 flanged to DIN 2635 form D [standard flat face, roughness Ra = 3.2 – 6.3 µm (N8/N9)]

or: RK 16A DN 65 PN 40 for flange to EN 1092-1 form D (groove/groove face)

Roughness Characteristics

Roughness class (old)	Ra	Rz	Rt	CLA µ"
	[µm]	[µm]	[µm]	[µin]
N1	0.025	0.22 - 0.30	0.24 - 0.40	1
N2	0.05	0.45 - 0.60	0.49 - 0.80	2
N3	0.1	0.8 - 1.1	0.85 - 1.45	4
N4	0.2	1.0 - 1.8	1.10 - 2.40	8
N5	0.4	1.6 - 2.8	1.75 - 3.60	16
N6	0.8	3.0 - 4.8	3.2 - 6.0	32
N7	1.6	5.9 - 8.0	6.3 - 10	63
N8	3.2	12.0 - 16.0	13.0 - 19.5	125
N9	6.3	23 - 32	25 - 38	250
N10	12.5	46 - 57	48 - 68	500
N11	25	90 - 110	95 - 130	1000
N12	50	160 - 220	190 - 250	2000

Definition of frequently used abbreviations for valves & steam traps

PN, Class	Pressure class acc. to EN, ASME body of rules
PMA	Maximum allowable pressure that the valve / trap body can withstand
TMA	Maximum allowable temperature that the valve / trap body can withstand
p/T	Maximum pressure as a function of temperature that the valve / trap body can withstand
ΔP	Operating differential pressure
ΔPMX	Maximum differential pressure (difference between operating pressure and operating back pressure)
TMO	Maximum operating temperature for which the operation of the equipment is guaranteed
PMO	Maximum operating pressure for which the operation of the equipment is guaranteed
PMOB	Maximum operating backpressure for which the operation of the equipment is guaranteed
PO	Operating pressure, measured at the valve / trap inlet
TO	Operating temperature, measured at the valve / trap inlet
PS	Maximum service pressure
TS	Maximum service temperature

Designation	Type	Product Range	Page
Air drier and purifier	TP	C	163
Air vent	BK, MK	A1	6 – 9
Ball-float steam trap	UNA	A1	10 - 15
Blowdown receiver	VDM	C	161
Blowdown valve, continuous (with electric actuator)	BAE	B	138 – 139
Blowdown valve, continuous (without actuator)	BA	B	138 – 139
Blowdown valve, intermittent (with pneumatic actuator)	MPA	B	142 – 143
Blowdown valve, intermittent (without actuator)	PA	B	142 – 143
Bus cable	–	B	-
Check valve	NAF-Check	A2	59 - 60
Check valve, dual-plate	BB	A2	50 - 54
Condensate dampening pot	ED	C	162
Condensate drain valve	AK	A1	20 – 21
Condensate lifter	UNA 25 PS, UNA 25 PK	A1	26
Condensate pump	CR, CRN, ASK	C	-
Condensate receiver tank	SDL / SDS	C	151 - 152
Condensate recovery and return system	Quick CC	C	150
Condensate return unit, steam-powered	KH, FPS	C	153
Conductivity controller	LRR	B	129 - 133
Conductivity electrode	LRG	B	128 - 135
Conductivity switch	LRS	B	132 - 135
Connecting kit	–	A1	33
Connector for electrode LRG	–	B	137
Continuous blowdown valve, with electric actuator	BAE	B	138 - 139
Continuous blowdown valve, without actuator	BA	B	138 - 139
Control unit	SRL	B	118 - 119
Control unit, conductivity	LRR	B	129 - 133
Control valve	GCV, ZK	A4	74 - 79
Control valve, high-pressure	ZK	A4	75 - 79
Cooling water control valve, Gestramat	CW	A4	64 - 65
Deaerator dome	NDR	C	-
Desuperheater	KD	C	155
Digital display	GIA	B	-
Display unit for process data	SPECTOR <i>control II</i>	B	106 – 107
Drain module	QuickEM, QuickEM-Control	A1	30 - 32
Drain valve	AK	A1	20 – 21
Dual-plate check valve	BB	A2	50 - 54
Electrode, conductivity	LRG	B	128 - 135
Electrode, level	NRG	B	102 - 105
Electronic control unit	SRL	B	118 - 119
EMC interference suppression	–	B	-
Feedwater tank	SW	C	158
Filter controller (for supply air)	FRS	B	154
Flash vessel systems	VD	C	160
Flow computer, flowmeter	SPECTOR <i>control Flow</i>	B	147
Flowmeter	SPECTOR <i>control Flow</i>	B	147
GESTRAMAT, cooling water control valve	CW	A4	64 - 65
Gravity circulation check	SBO	A2	37
Heat-transfer equipment	PWT-XPS	C	157

Designation	Type	Product Range	Page
High-capacity steam trap	TK 23, TK 24	A1	20 - 21
High-pressure control valve	ZK	A4	75 - 76
Indicator, digital	URB	B	104 - 105
Intermittent blowdown valve, with pneumatic actuator	MPA	B	142 - 143
Intermittent blowdown valve, without actuator	PA	B	142 - 143
Kalorimat, return-temperature control valve	BW	A4	66 - 68
LED analog display	MB 1	B	-
Level controller	NRR	B	104 - 105, 114 - 115
Level controller/limiter	URS	B	103, 124 - 125
Level electrode	NRG	B	102 - 105
Level limiting controller	NRG	B	102 - 105
Level monitoring (Bus, Compact)	NRG, NRGs, NRGT	B	102 - 117
Level pot	MF	B	118 - 119, 137
Level switch	NRS	B	104 - 105, 114 - 115
Level transmitter	NRT	B	-
Lift restriction	Lift restriction RK	A2	36
Liquid level gauge	-	C	-
Low-pressure trap	MK20	A1	20 - 21
Mixing cooler	VDM	C	161
Monitoring equipment for steam trap	VK, VKE, VKP, VKP 41 plus	A1	28 - 29
NAF Check valve	NAF-Check	A2	50 - 54
Non-return valve (for sandwiching between flanges)	RK	A2	38 - 49
Non-return valve, screwed	MB	A2	38 - 39
Oil and turbidity detector	OR	B	144 - 145
Oil detector	ORGS	B	146
Power supply unit	Sitop	B	-
Pressure controller & filter for supply air	FRS	B	154
Pressure gauge	-	C	-
Pressure switch	DSH, DSL, DSF, 65-1K Manocomb	B	88, 90, 95, 97
Pressure transducer	CK	B	-
Pressure transmitter	DRT	B	89 - 90
Pressure-maintaining valve	5610	A4	70
Pressure-reducing valve	5801	A4	69
Pump control	NRSP	B	116 - 117
Pump steam trap	UNA 25 PK	A1	26
Radar level transmitter	705 MS	B	114 - 115
Return-temperature control valve, Kalorimat	BW	A4	66 - 68
Rhombuline (steam traps)	AK 45, BK 45, DK 45, MK 45, UBK 45	A1	
Roughness characteristics	-	-	187
Safety power supply unit	Sitop	B	-
Safety valve	GSV	A6	80
Sample cooler	PK	C	-
Self-acting temperature control valve	Clorius	A4	71 - 73
Sightglass, Vaposkop	VK, GSG	A1	28 - 29
SIL (Safety Integrity Level)	NRG 16-50, NRS 1-50	B	110 - 111
Softcontrol Data	-	-	146
Solenoid valve	8...	C	-
Steam drier / steam purifier	TD	C	163
Steam trap for large condensate flowrates	GK 11/21	A1	20 - 21

Designation	Type	Product Range	Page
Steam trap for large scale installations	DK	A1	16 – 17
Steam trap for SIP applications	SMK	A1	18 – 19
Steam trap for UNIVERSAL (Swivel) connector	BK 36A/7, MK 36A/7., DK 36A/7	A1	22
Steam trap monitoring equipment	VKE	A1	28– 29
Steam trap with adjustable discharge temperature	UBK	A1	20 – 21
Steam trap with ball float	UNA	A1	10
Steam trap with Duo S. S. (bimetallic) regulator	BK	A1	6 – 7
Steam trap with membrane regulator (thermostatic capsule)	MK	A1	8 – 9
Steam traps	BK, MK, SMK,TK	A1	–
Steriline	SMK	A1	18 – 19
Stop valve	GAV	A8	83 – 84, 118 – 119
Strainer	GSE, SZ	A7	81 – 82
Stroke limiter	Lift restriction RK	A2	36
Swing check valve	CB	A2	55 – 56
Swing check valve	WB	A2	57 – 58
Switch, conductivity (TDS)	LRS	B	132 – 135
Syphon	–	B	–
Temperature sensor	TRG	B	124 – 127
Temperature control valve	BW	A4	66 – 68
Temperature control valve, self-acting	Clorius	A4	72 – 73
Temperature controller	KS 92	B	–
Temperature limiter	TRS	B	126 – 127
Temperature switch	TRS	B	124 – 125
Temperature preamplifier	TRV	B	126 – 127
Test unit for steam traps	NRA	A1	28 – 29
Thermodynamic steam trap	DK	A1	16 – 17
Thermometer	–	C	–
Traptest	VKP 41 plus, VKP 41 plus Ex	A1	28 – 29
Traptest, steam trap monitoring	VK, VKE, VKP, VKP 41 plus, VKP 41 plus Ex	A1	28 – 29
Universal connector	TS, UC, UCY	A1	23 – 24
Universal controller	KS 92	B	–
Universal operating unit	URB	B	104 – 105
Vapophone	VKP 10	A1	28 – 29
Vaposcope (sightglass)	VK, GSG	A1	28 – 29
Vortex flow meter	84 W-U	B	147
Water-level indicator	16/14	C	–

Type	Product	Product Range	Page
AK	Condensate drain valve	A1	20 – 21
ASK	Condensate pump	C	–
BA	Continuous blowdown valve, without actuator	B	138 – 139
BAE	Continuous blowdown valve, without electric actuator	B	138 – 139
BB	Dual-plate check valve	A2	50 – 54
BK	Steam trap with Duo stainless steel (bimetallic) regulator	A1	6 – 7
BK 36A/7	Steam trap for universal connector	A1	22
BW	Return temperature control valve, Kalorimat	A4	66 – 68
CB	Swing check valve	A2	55 – 56
CK	Pressure transducer	B	–
Clorius	Self-acting temperature controller	A4	71 – 73
CR	Condensate pump	C	–
CW	Cooling water control valve, Gestramat	A4	64 – 65
CRN	Condensate pump	C	–
DK	Thermodynamic steam trap	A1	16 – 17
DRT	Pressure transmitter	B	89 – 90
DSH	Pressure switch	B	97
DSL	Pressure switch	B	97
DSF	Pressure switch	B	88, 90, 95
ED	Condensate dampening pot	C	162
EK	Injection cooler	C	155
ER	Level electrode	B	–
FPS	Steam-powered condensate return unit	C	154
FRS	Pressure controller & filter for supply air	B	–
GAV	Stop valve	A8	83 – 84, 118-119
GIA	Digital indicator	B	–
GK 11/21	Steam trap for large condensate flowrates	A1	20 – 21
GRDE	Steam regenerator	C	156
GSF	Strainer	A7	81
GSG 405/424	Sightglass for steam traps	A1	–
GSV	Safety valve	A6	80
KD	Desuperheater, water bath	C	155
KH	Steam-powered condensate return unit	C	153
KS 92	Universal controller	B	–
Lift restriction RK	Lift restriction	A2	36
LRG	Conductivity electrode	B	128 – 135
LRR	Conductivity controller	B	129 – 133
LRS	Conductivity switch	B	132 – 135
LRV	Conductivity preamplifier (spare part)	B	–
MB	Screwed non-return valve	A2	38 – 39
MB 1	LED analog display	B	–
MF	Level pot for electrodes	B	118 – 119, 137
MK 20	Steam trap for low pressure installations	A1	20 – 21
MK	Air vent	A1	8 – 9
MK	Thermostatic steam trap with membrane regulator	A1	8 – 9
MPA	Intermittent blowdown valve with pneumatic actuator	B	142 – 143
MK 36A/7.	Steam trap for universal connector	A1	22
NAF-Check	Check valve	A2	59 – 60
NDR	Deaerating dome	C	–
NRA	Trap testing unit	A1	29
NRG	Level limiter	B	102 – 105
NRG	Level electrode	B	102 – 105
NRR	Level controller	B	104 – 105, 114 – 115

Type	Product	Product Range	Page
NRS	Level switch	B	104 – 105, 114 – 115
NRSP	Pump control	B	116 – 117
NRT	Level transmitter	B	–
OR	Oil & turbidity detector	B	144 – 145
ORGS	Oil detector & alarm	B	146
PA	Intermittent blowdown valve without actuator	B	142 – 143
PK	Sample cooler	C	–
PWT-XPS	Heat exchanger unit	C	157
QuickEM, QuickEM-Control	Draining module	A1	30 – 32
RK	Non-return valve	A2	38 – 49
SBO	Gravity circulation check	A2	37
SDL	Condensate recovery and return system, vertical	C	151 – 152
SDS	Condensate recovery and return system, horizontal	C	151 – 152
SDR	Condensate recovery and return system	C	150
Sitop	Safety power supply unit	B	–
SMK	Steam trap for SIP applications, Steriline	A1	18 – 19
<i>SPECTORcontrol II</i>	Display unit for process data	B	106 – 107
<i>SPECTORcontrol Flow</i>	Steam flowrate calculator	B	147
SRL	Monitoring unit	B	118 – 119
SW	Feedwater tank	C	158
Swivel	Steam trap for universal connector	A1	23
SZ	Strainer, wafer-type	A7	82
TA	Blowdown system, programme-controlled	B	140 – 141
TD	Steam separator, steam drier/purifier	C	163
TK 23, TK 24	High-capacity steam trap	A1	20 – 21
TP	Steam drier/purifier	C	163
TRG	Temperature sensor / resistance thermometer	B	124 – 125
TRV	Temperature preamplifier	B	124 – 125
TS	Universal connector unit with stop valve	A1	23 – 24
UBK	Steam trap with adjustable discharge temperature	A1	20 – 21
UC, UCY	Universal (swivel) connector	A1	23 – 24
UNA 14	Air trap	A1	25
UNA	Ball-float steam trap	A1	10 – 15
UNA 25 PK	Pump trap	A1	26
UNA 25 PS	Condensate lifter	A1	26
URB	Control terminal & display unit	B	104 – 105
URS	Safety control unit	B	103, 124 – 125
VD	Flash vessel system	C	160
VDM	Blowdown receiver, Mixing cooler	C	161
VK	Vaposcope, sightglass	A1	28
VKE	Test set, steam trap monitoring	A1	28 – 29
VKP 10	Steam trap monitoring system	A1	29
VKP 41 plus	Traptest, test equipment for steam traps	A1	29
VKP 41 plus Ex	Traptest, test equipment for steam traps	A1	29
VRM	Service case	B	136 – 137
WB	Swing check valve	A2	57 – 58
ZK	Control valve	A4	75 – 79
5610	Pressure-maintaining valve	A4	70
5801	Pressure-reducing valve	A4	69
65-1K Manocomb	Pressure switch	B	–
705	Radar probe	B	114 – 115
8....	Solenoid valve	C	–
84 W-U	Vortex flowmeter	B	147

Note: Responsible care has been taken in preparing this illustrated catalogue. GESTRA reserves the right to make corrections and changes. Illustrations in our printed literature are liable to alteration and are not intended to be binding. We also reserve the unrestricted property and copyright in all estimates, drawings or related documents, which must not be made available to third parties.



GESTRA AG

Münchener Str. 77 · 28215 Bremen · Germany Tel. +49 421 3503-0 info@de.gestra.com
Postfach 10 54 60 · 28054 Bremen · Germany Fax +49 421 3503-393 www.gestra.com

850128-00/12-19mm · © 2019 · GESTRA AG · Bremen · Printed in Germany · Technical modifications reserved

